

**“Protection, promotion, and touristic valorisation of Adriatic maritime heritage”**

Priority Axis: Environment and cultural heritage

3.1 – Make natural and cultural heritage a leverage for sustainable and more balanced territorial development

## D 4.2.2 – Technical description of little boats

WP4 – TOURISM INFRASTRUCTURE OF THE COMMON TOURISM PRODUCT  
ACTIVITY 4.2 – RENOVATION OF SMALL BOATS

12/2021

PARTNER IN CHARGE (PP5)

PARTNERS INVOLVED (LP, PP1, PP3, PP4, PP5, PP6, PP7, PP9)

Status: Final  
Distribution: Public document

## Table of Contents

INTRODUCTION TO THE TECHNICAL DESCRIPTIONS OF LITTLE BOATS .....	1
LP - PRIMORJE-GORSKI KOTAR COUNTY .....	13
Guc MD 31.....	14
Guc MD 400.....	27
Pasara „Diodata“ CS 1079 .....	41
Guc OP 3871.....	56
Gajeta KK 39 .....	69
Pasara OP 115706 .....	83
PP 1 - MUNICIPALITY OF MALINSKA-DUBASNICA.....	96
Pasara MK 34.....	97
Pasara MK 73.....	111
PP 3 - ASSOCIATION AND ECOMUSEUM "HOUSE OF BATANA" .....	124
Batana <i>Peicia</i> .....	124
PP 4 - MUNICIPALITY OF CERVIA.....	133
Lancia <i>Assunta</i> .....	133
Cutter <i>Caporale Leone</i> .....	149
Cutter <i>Delfino</i> .....	158
Lancia <i>Maria</i> .....	168
Lancia <i>Tre Sorelle</i> .....	185
Lancione <i>Tre Fratelli</i> .....	198
PP 5 - MUNICIPALITY OF CESENATICO .....	208
Lancia <i>Aldina</i> .....	208
Bragozzo <i>San Marco</i> .....	219
PP 6 - CIHEAM IAMB .....	230
<i>Trechandiri Portus Veneris</i> .....	230
Schifetto <i>Delfino</i> .....	238
PP 7 - MUNICIPALITY OF SAN BENEDETTO DEL TRONTO.....	247
Lancetta <i>Tastutina</i> .....	247
Lancetta <i>Stella del Mare</i> .....	263
PP 9 - MUNICIPALITY OF TKON .....	278
Gajeta <i>Bruno</i> .....	278
Kaić <i>Mateus</i> .....	289

## DISCLAIMER

This document was written by Davide Gnola, Director of the Maritime Museum Museum of Cesenatico, on behalf of PP5 Municipality of Cesenatico, and reflects the author's views; the Programme authorities are not liable for any use that may be made of the information contained therein.

Each partner is responsible for the information provided in the technical descriptions as well as for the technical attachments and the correctness of the translation.

## INTRODUCTION TO THE TECHNICAL DESCRIPTIONS OF LITTLE BOATS

### ***Premise***

The Application Form of ARCA Adriatica, at WP 4.2, starting from the consideration that “currently there are very few samples of traditional boats left [...] mostly, they are neglected and almost destroyed” provided that “in order to avoid the disappearance of such a valuable part of the maritime heritage”, is financed the restoration of 23 small wooden boats (12 in Italy and 11 in Croatia), leaving the choice of criteria by which to choose the boats to the Centers of Excellence set up on another project WP.

The aim was therefore to preserve the small wooden boats as a central and living part of the common Adriatic heritage, and for this reason it was foreseen that at the end of the restoration the restored boats will be shown in the port, thus participating in the overall aims of the project and scheduled activities.

The identification and restoration of the boats was in fact a central and characterizing element of the project, because traditional boats are the central and most visible witnesses of the maritime heritage: this was also decisive for involving the Centers of Excellence, the owners, associations, shipyards - in other words the most active part of the maritime community - in the ARCA Adriatica project. The ARCA project itself, moreover, also arises from previous network projects and actions in which traditional boats were the protagonists of actions which were decisive for promoting local maritime culture, the participation of coastal communities, the awareness of operators and authorities towards a more experiential and sustainable tourism.

In addition to other outputs dedicated to documenting the restoration of boats, the project provided the creation of a “joint report” in order to collect together the technical descriptions provided for each boat by the involved partners, in order to have an overall look at this aspect of maritime heritage, and attempt a quantitative and comparative analysis.

The technical description form was developed by the WP coordinator (see template attachment) with a layout of fields divided into four sections:

- the first section offers the main data of the boat, such as the name, registration number if any, the home port, the owner; but first of all the motivation for choosing that single boat; then the material data of the boat, starting from its traditional type, dimensions, materials, sail rig, etc.; finally, the history of the boat, such as the construction site and shipbuilder, use, various events more or less documented;
- the second section goes into the technical description of the hull and the other salient elements, including measurements, details on the type of rig and steering, as well as information on any previous restorations;
- a third section provides a description of the restoration, starting from its motivations, the phases in which it took place, the choices made, and of course the name of the person or site that was responsible for it;
- finally, a section of attachments completes the descriptive form, and in particular reliefs and technical drawings that may be used for any future reconstructions and restorations.

### ***The traditional boats of Adriatic sea***

The small Adriatic boats that have been restored by LP/PPs of ARCA are part of a substantial unity, from the point of view of material culture, in relation to the traditional types, the materials used, the construction techniques, their use and also the dynamics that have marked their exit from the job market, and entry - for a limited number of specimens - into the world of pleasure boating and cultural recovery.

Traditional working Adriatic boats are in fact a subset, quite characterized, of the world of traditional Mediterranean boats: all of small or medium size (almost all under 16 meters, with the exception of some types used for transport), used for coastal or offshore fishing in a small sea as the Adriatic, built in wood by shipbuilders on the basis of leading measures and craftsmanship handed down from father to son. They have evolved into different types depending on the geographical area and the type of fishing / use, and then disappeared in the second half of the XXth century following the introduction of the engine and different industrial fishing techniques; some of these have survived thanks to some enthusiasts who have restored them, or had them built in more recent years with the same model as the original ones.

The 23 boats restored as part of the ARCA Adriatica project on both shores of the Adriatic sea are a very representative sample of this cultural element: we have in fact, according to the reports and materials provided by the partners:

- 4 *pasara* (it. *passera*), round hull, truncated stern, medium size, widespread on the east coast and in a short stretch of the Italian coast from Grado to Trieste;
- 2 *gajeta* (not present in Italy), also with a round hull, with many variants;
- 3 *guc* (it. *gozzo*), round hull, small size, common only on the east coast of Adriatic (in Italy it is present but only in the Tyrrhenian Sea);
- 1 *batana* (it. *battana*), with a flat bottom, widespread throughout the northern Adriatic (from Ancona to Zadar), but with significant variations;

- 2 beach cutters, a very particular boat, created and used between the 1950s and 1970s on the coast of Romagna in relation to the big growth of tourism for the purpose of transporting people from beaches to short trips to the sea;
- 4 *lancia*, a sort of Romagna coast version of the *guc*, round hull, sleek lines;
- 1 *lancione* (big *lancia*), larger version with two masts of the *lancia*, not present on the coast of Croatia;
- 1 *bragozzo*, a typical Venice lagoon (mainly Chioggia) fishing boat, with a flat bottom, also common in Romagna, present only occasionally in Croatia;
- 2 *lancetta*, variant typical of Marche region coast of the *lancia* similar to the Romagna *lancia* and the *guc*;
- 1 *schifetto*, small Latin sailboat typical of southern Italy;
- *kajc* (it. *caicco*), a name which in Italy generically designates a wooden boat for transporting people;
- 1 *trechandiri*: it is in fact a Greek and Turkish type boat, which arrived in the Adriatic by chance recently and is now present in Tricase.

These are denominations that lead to types that are sometimes similar to each other (e.g. the *guc*, the *lancia*, the *lancetta*), sometimes different (e.g. the flat-bottomed *batana* compared to other round-bottomed boats), and which show significant transformations in some cases following the motorization. The technical differences between these types with all their variants can only be analyzed by specialists and on the basis of a much wider sampling than the one presented here, which however has the merit of providing a very representative summary, especially of those types of greater success that have had also the opportunity to be handed down to the present day.

### ***The structure***

The general technical aspect of these boats is the typical one that established in the Mediterranean since late antiquity, characterized by an internal structure that is a sort of skeleton, with frames grafted onto a keel, made with compact and hard wood (almost always oak), and covered with various types of lighter wood planks, then made waterproof by introducing tow and tarred lint (*calafataggio*). The shape of the hull, round or flat, more or less thin, some constructive differences, the presence of a more or less large deck and superstructures, define and differentiate the types. In fact, in the Adriatic there are no different materials and construction solutions in this type of boats (e.g. use of leathers, metal, construction solutions or different types of hulls) that are found in maritime cultures, including Mediterranean ones. For this reason, the construction techniques are also similar, essentially based on shipbuilders who work in small yards and personally follow all the construction steps, starting from cutting planks and parts from the tree trunks until to painting and rigging the boat.

A remarkable difference that we also can see on the technical descriptions provided by PPs is between the boats built in the first half of the XXth century, which show the lines of the “pure” hull designed for sail propulsion, and those built later, which have the propeller axis line that transforms the hull and the stern part, and sometimes even inserts a small deckhouse. However, almost all boats have now motor propulsion (inboard or outboard), while the use of oars is much more widespread on the Croatian side than on the Italian one.



### ***The rig***

A very important element that should be highlighted is the rig: the Adriatic sea is in fact the site where the “al terzo” sail (usually translated “lugsail”, although is not the same) was developed, a peculiar rig of great interest. Most of the boats restored have “al terzo” rig; however, the presence of the two lateen sail boats in Tricase (PP9) and the one in Tkon (PP9), shows that Adriatic is “splitted” in two areas: “al terzo” at the north and lateen at south, with an interesting mixed area around Zadar, as Tkon shows.

Also interesting is the unusual presence of two beach cutters from Cervia rigged Marconi (the triangle sail that is usual onboard of modern pleasure boats), which represent, as we have said, a very peculiar moment of Adriatic work boats.

### ***The technical descriptions and the drawings***

In general, the technical descriptions provided have been compiled by the partners with an excellent degree of precision and accuracy, which in some cases can be defined as exemplary in terms of detail. Almost all partners have entrusted the work to engineers, naval architects and experts and this is reflected in the compilation of the descriptions. With regard to some particularly detailed elements, such as some measures and types of wood, the level of the descriptions may vary also due to the difficulty of collecting some data on the boat. In general, however, all the descriptions fulfill the objective, which was to provide a technical description of the restored boats and to provide - also through technical drawings and reliefs - the tool to ensure their eventual reproduction in the future.

Regarding the technical drawings, an important warning is needed: as mentioned above, traditional boats were not built on the basis of drawings or plans drawn up by a naval designer, but according to the “key measures”, leading shapes, and experience of the shipbuilder (*maestro d’ascia*) who almost never left written traces. For this reason, all the technical drawings of traditional boats derive from “as built” surveys carried out on single hulls, sometimes made and used by model makers (there are some both in Italy and in Croatia who are particularly experienced). Sometimes the surveys are carried out using classic tools (key measurements made with string, plumb line, goniometer, etc.), sometimes simply with freehand drawings accompanied by some measurements, while more recently digital systems based on laser scanner(point cloud) or photogrammetry. These later systems have been used in various boats restored in the ARCA project and therefore digital materials have also been produced which it has not been possible to show into the technical descriptions (where however there are some renderings), but which are available for partners for reconstruction purposes, and also for virtual show of the boat.

After the overall look, it is possible to take a closer look at the boats restored by the individual PPs, highlighting the peculiar characteristics.

### **LP Rijeka**

The LP restored six boats of which 3 *guc*, 2 *pasara*, 1 *gajeta*, all very interesting in terms of type, 3 of which were built in the first half of the century (1931, 1933, 1945) by famous shipbuilders; the 3 *guc* are representative of the very sleek boats that were used for fishing and to transport people and things in Kvarner and its islands, and also the other boats built later show

how much the traditional skills of boatbuilding has remained alive among the shipyards allowing these types of boats to be used also for pleasure to the present day.

The great accuracy and detail of the technical reports should be mentioned, which make it possible to ideally reconstruct every detail of the boat and the restorations; There is also a complete technical drawing for each boat with views and measurements on all sides, obtained from the direct survey.

### **PP 1 Malinska Dubasnika**

The two boats restored by PP 1 are two substantially “twin” *pasara* in terms of type, size, year of construction, but distinct from others similar, as the technical descriptions says, “by specific features typical for this kind of boat: a flat transom and a slightly curved bow with the stem inclined forward”. This is a good example of how beyond the general characteristics of the typologies, in some coastal areas the boats tended to develop peculiar characteristics in reference to certain environmental characteristics, or of fishing, or simply due to the influence of some shipyard or boatbuilder. In this case, the two boats were built in relatively recent years (the 1980s) and therefore for recreational use.

Also in this case, the high level of technical descriptions and drawings provided should be noted.

### PP 3 Rovinj

Rovinj has chosen to restore and describe its most typical boat, the protagonist of one of the most interesting ecomuseums in the Mediterranean. *Batana Peicia* is a boat of very recent construction (2015), but it was made by recovering and respecting traditional techniques and materials. It is the only *batana* of the group of restored boats, and this is important because it allows us to document a boat which, as mentioned above, is the visible testimony of a common material cultural heritage that extends to both shores of the Adriatic Sea.

### PP 4 Cervia

Were chosen some boats varied from each other and very representative of the types of the Italian coast and in particular of the Romagna coast: *Caporale Leone* and *Delfino* are two “beach cutters”, a type of boat born on this coast in the post-war period in order to bring to sea tourists starting from the beach: so it is not a pleasure boat, but should be considered maybe the last type of traditional work boat. Shapes and rigs are very different from those of the previous types, and follow those of contemporary regattas and pleasure boats (e.g. the *Flying Dutchman*), with Marconi rig, more practical than the “al terzo” sail, light and fast hull with little wet surface and a retractable keel to reach almost until the beach.

Three other boats - *Maria*, *Tre Sorelle*, *Assunta* - are *lancia Romagnola* type, very similar in lines to the *guc* of the eastern shore and to the *lancetta* of the Marche coast. Also in this case, as for the LP *gucs*, we are faced with three valuable specimens, because *Assunta* was built in 1925 and is recognized also as “boat of patrimonial value” by the Italian Minister of Culture, and also the other two, built in 1949 and 1958, are the work of a renowned shipyard.

*Tre Fratelli*, built in 1966 by Riccardo Brizzi, one of the first Italian scholars of traditional boats, is an example of a *lancione* (big *lancia*) a boat similar in size to the *lancia*, but larger in size and with two masts with “al terzo” sails, also representative of a typology present only on the Italian coast.

### **PP5 Cesenatico**

The Cesenatico Maritime Museum has restored two museum boats belonging to its floating section. The first is a *lancia Romagnola*, completely similar to the three of Cervia, built in 1949 also in Cattolica.

The *bragozzo San Marco*, is a medium-large type of boat, typical of the Venice lagoon and in particular of Chioggia, but also very common on the Romagna coast. It is the only exemplar in the group of ARCA restored boats, so it is interesting to document and show this type, that was built in a large range of time since end of XVIIIth Century until the '50s and '60 of the last.

### **PP 6 CIHEAM IAMB Bari**

*Portus Veneris* is a large two masted boat, which belongs – as report says - to a type comparable to that known in Greece as *trechandiri* and in Turkey as *tirhandil*; the boat was found abandoned on the shore in 2002 probably after being used for immigration from Albania. It is therefore not a common boat in the Adriatic, but it is at the same time very significant because it bears witness to historical and social events that have been typical of our sea until very recent years, leading to exchanges of goods, people, cultures, and therefore also of naval types. The boat was probably

built in the early decades of the 20th century, and perhaps had a different rig (auric perhaps), and has now been equipped with a latin sail.

*Delfino*, on the other hand, is a much smaller boat, and testifies to a naval type, such as the *schifetto* (small hull: as *schifo*, *scafo*, *skiff*), with a round hull, latin sail, very similar to the *guc - gozzo* found in Croatia and Italy, even at south.

### **PP 7 San Benedetto del Tronto**

The two *lancetta Marchigiana* boats are a type of boat that we can find only on this coast, even if it takes some details from other types: the hull bottom is round like that of the *lancia Romagnola* and the *guc* or the *pasara*, but the bow is “duck breast” like that of the *trabaccolo* (a very common type of fishing boat that is not present in the group of restored boats). The *lancette* are generally not very long, they remain under 10 meters, because otherwise they are called *paranze* and have different characteristics and are much more massive. It is important to note that unlike other types of boats, such as the *batana*, the *lancia*, *guc*, *pasara* which have a higher number of specimens, not many *lancette* have been preserved, also due to the custom of destroying boats that are no longer usable by burning them.

## PP9 Tkon

*Kaic* is a denomination that in Italy is associated with larger boats for passenger transport, used in the Greek and Turkish seas: therefore instead, here it designates a boat that is always for passenger transport, but much smaller. *Mateus* is of old construction (1920) and therefore interesting as a model.

*Gaeta Bruno* is a typical boat of the island of Pašman and in general of Dalmatia, characterized by medium size and mixed use (fishing, transport of people and things): it's quite different if compared to the Italian coast, because there the boats were used almost exclusively for fishing and therefore only by fishermen, while between the islands of Kvarner and Dalmatia the boat could be used for more general purposes, and therefore sometimes also by other members of the family.

As said before, Pašman is located right on the border between the diffusion area of the lateen and that of the "al terzo" sail, and it is therefore significant that the two boats here represented have the two different types of rig.

NB:

For bibliography, photographs, technical drawings see the individual descriptions.

## LP - PRIMORJE-GORSKI KOTAR COUNTY

### Guc MD31





## Guc MD 31

### Section 1: boat data

	<p><b>Motivation for the selection of the boat</b></p> <p><i>(the grid has the function of identifying and exposing the reason that motivated the selection of this specific boat for restoration and documentation)</i></p>
<b>Ethnographic / cultural significance</b>	<p><i>E.g. does the boat represent traditional boat types (e.g. bragozzo, batana, etc.) or traditional fishing techniques, crafts, traditions?)</i></p> <p>The boat represents a very valuable example of the traditional guc boat of older construction (she is from 1933), typical for the Kvarner area, very few of which are still preserved in their original form.</p>
<b>Historical significance</b>	<p><i>Is the boat related to any historical event? (include sports scores of particular relevance, personalities, etc.)</i></p> <p>It is very interesting that the boat was made by a local self-trained shipbuilder Zenon Premuš from Zagore who made several boats. The boat was used for fishing and was stationed in the bay of Stupova where she was beached with wooden hand winches (locally called argan). Various fishing tools were used in fishing (gillnets, longlines, spears, fishing lines, etc.).</p>
<b>Technical / nautical significance</b>	<p><i>Do the boat has particular design solutions, or represents nautical types of boats (e.g. Olympic classes, series, etc...), or the work of some famous designer?</i></p> <p>The Kvarner guc has, just like the others, very slender lines (the boat was made as a rowing boat) with a particularly sharpened stern, which is a feature of older guc boats. In terms of construction, the interesting thing is that the stem and apron are made of one piece of wood, as well as the sternpost and inner post.</p>
<b>Replica</b>	<p><i>Is the boat an exact reproduction of a boat matching one of the above criteria?</i></p> <p>The boat MD 31 is not a replica, but an original boat from 1933.</p>
	<p><b>Identification data</b></p>
<b>Current boat name</b>	-

<b>Current register number (if registered)</b>	MD 31
<b>Current harbour / location</b>	Port of Mošćenička Draga and occasionally the port of Brseč
<b>Current owner</b>	
<b>Contact person / site</b>	<i>Indicate name and contact data (e.g. tel., email, others) in order to have if needed further infos about the boat</i> 

	<b>Material data</b>
<b>Boat type / Traditional type</b>	<i>Name of the traditional typology (e.g. bragozzo, batana, also giving further specification related to place) or boat's type (e.g. cutter, dinghy, etc.)</i> Guc (Kvarner guc boat of older construction)
<b>Original function</b>	<i>Fishing, cargo or passengers transportation, leisure, sport,...</i> The boat was used for small coastal fishing.
<b>Rig</b>	<i>E.g. "al terzo", lateen, auric, etc.</i> The boat has traditional rigging (one mast, lugsail and a jib).
<b>Length</b>	4,76 m (length overall)
<b>Breadth</b>	1,54 m (breadth moulded)
<b>Draught</b>	0,32 m (from below the keel to the waterline of the hull)
<b>Tonnage or weight (if known)</b>	-
<b>Main materials and construction features</b>	<i>Indicate main construction features, e.g. hull materials and type of building (e.g. traditional wood building, oak wood, metal hull, etc.)</i> Structural elements (keel, stem, sternpost, apron, inner post, bilge stringers, sheer strakes, caprail and thwarts) are made of oak, while the floors and frames are made of mulberry. The planking is made of spruce (carvel).

	<b>Historical data</b>
<b>Date / period of construction</b>	<i>E.g. 1935 / the 50s, etc</i> 1933.
<b>Construction place / shipyard or builder</b>	<i>Indicate the place or if unknown the area, and the name of shipyard or shipbuilder</i> The boat was built by Zenon Premuš in Zagore near Brseč.
<b>Designer, if any</b>	The shipbuilder Zenon Premuš himself.
<b>Historical presentation</b>	<i>Brief description of the life of the boat with reference to its original use and to events preceding the present restoration; indicate here also the previous names and register numbers, and previous owners, and restorations</i>  The boat was used for small coastal fishing and was stationed in the bay of Stupova where she was beached with wooden hand winches (so called argans). Various fishing tools were used in fishing (gillnets, longlines, spears, fishing lines, etc.).  The first owner was the shipbuilder Zenon Premuš himself. The boat was then inherited by his son (Juraj Premuš). The boat was bought by Andrej Galović in 2008, and in 2013 by the current owner Ermano Jedretić.  Apart from regular maintenance, there were no significant previous renovations.
<b>Bibliography / links</b>	<i>Give a bibliography of published books or articles, or links to Internet resources (e.g. sites, social) on this specific boat (not about type or in general)</i>  -

## **Section 2: technical description**

<b>Metric data and shape of the hull</b>	<i>Indicate the salient measurements (in addition to those of length and width) and describe the general shape of the hull (e.g. sheer, length / width proportion, etc.)</i>  Guc is 4.76 m long (over all), 1.54 m wide with a draught of 0.32 m and a height in the middle of 0.80 m. The boat has sixteen frames (frames F1 to F16), midships (theoretical main frame) is located between the frames F8 and F9.
--	--

	<p>The ratio of length and breath <math>L/B=3.1</math>, the ratio of breath and draught <math>B/T=4.8</math>, the ratio of length and draught <math>L/T=14.9</math>, the ratio of length and height <math>L/H=5.95</math>, and the ratio of breath and height <math>B/H=1.9</math>.</p> <p>Guc is characterized by a very fine shape of the hull (slender lines) because the boat was designed as a rowing boat with a particularly sharp shape of the stern, which is a feature of older guc.</p>
<p><b>Structural parts (keel and frames)</b></p>	<p><i>Description of the structure of the boat, also indicating the number and measures of the frames, and other structural parts</i></p> <p>Structural elements (keel, stem, sternpost, apron, inner post, bilge stringers, sheer strakes, caprail and thwarts) are made of oak, while the floors and frames are made of mulberry.</p> <p>Keel (made of oak) extends throughout the entire length of the boat, 3.94 m, and connects to the stem and sternpost. The height of the keel along the entire length of the boat outside the hull is 13.5 cm at the bow and 12.5 cm at the stern. The keel is square in cross-section, 4.2 cm thick, with a sharp end at the bow and the stern.</p> <p>Stem and sternpost are made of oak, constructed together with the apron and inner post (stem and apron are made of one piece). The stem and the sternpost exceed the caprail by 7 cm and 3 cm, respectively. The connection with the stem and sternpost is made with an open Z scarf. The distinguishing trait of the guc is the fact that her stem and sternpost and apron and inner post are made in one piece, which provided extra strength.</p> <p>The frames and floors are made of mulberry. The boat has sixteen frames (frames F1 to F16). She is built by the 3-piece frame system (floor and the port and starboard side frames). Midships (theoretical main frame) is situated between F8 and F9 frames. The bow frames on the port and starboard side are positioned forward in relation to the floors, while the stern frames of the port and starboard side are positioned towards the aft in relation to the floors. The floors are connected to the keel by stainless steel bolts, 8 mm in diameter, passing through the entire height of the floor and keel. The floors are single-piece, 2.8 to 3.5 cm thick, exceptionally 4 cm (most often 3 to 3.5 cm). The width (height) of the floors along the keel are between 4.5 to 6.5 cm at the stern, 5 to 6 cm amidships, and 6 to 7 cm at the bow. The width of the floors at the sides is 4 to 4.5 cm at the stern, 4.5 to 5 cm amidships and 4.5 to 4.8 cm at the bow. There are limber holes (for</p>

	<p>the water), approximately 1.8 cm in diameter, cut in the floors at the bottom, to the port and starboard of the keel. The frames are 2.8 to 3.4 cm wide (most often they are 3.1 to 3.2 cm). The width of the frames at the bottom is the same as the floors, while at the top they are 2.9 to 3.6 cm wide. The frames and the floors overlap in the length from 14 cm to 22 cm (most often between 16 and 20 cm). The frames are connected to the floors with three stainless steel wood screws, dimensions 50 x 4 mm.</p> <p>The bilge stringers are made of oak. They are 4.5 to 6 cm wide (in the most part 6 cm) and 2 cm thick. They extend from the second to the fifteenth frame (F2 to F15). They are made in two pieces and they connect at the F10 frame with a vertical oblique joint. Besides providing longitudinal strength, the bilge stringers serve as side delimiters of the limber boards.</p> <p>The caprail, made of oak, is carried in the upper edge of the sheer strakes, fastened with stainless steel wood screws to the external and internal sheer strakes. Internal and external sheer strakes are made of oak. External sheerstrakes are single-pieces, while internal sheer strakes are made of two pieces. Internal sheer strakes are 4 cm wide and 1.5 cm thick. External sheer strakes are 7 cm wide at the stern to 8.5 cm at the bow, with 1.8 cm thickness.</p>
<p><b>Planking (external / internal)</b></p>	<p><i>Description of the planking, with measures, and type of waterproofing (e.g. caulking, epoxy, other</i></p> <p>The planking is carvelled, symmetrically made on both sides, from the keel to the external sheer strake, consisting of 9 planks on each side. The planks are 1.8 cm thick. As a rule, they are composed of several pieces, and they end at the stem or sternpost. Garboard strakes, made of oak, are fitted along the keel, while the other planks are made of spruce. The planks are fastened with stainless steel wood screws to the floors and frames. Screw heads are countersunk into the plank, while the holes are filled with epoxy and ground. The longitudinal seams between the planks and the heads on joints, including the stem and sternpost are caulked with cotton.</p>
<p><b>Deck and openings</b></p>	<p><i>Description of the deck and the number and size of the different openings</i></p> <p>The boat is deckless, open (with only thwarts). She has two central transverse thwarts and thwarts at the bow and the stern. The thwarts are made of oak of various thickness, all edges are rounded.</p>

	<p>The bow thwart, with a total width of 76 cm (in the direction of the boat buttocks), is approximately trapezoidal in shape with its sides following the curve of the hull at the bow. A part of the thwart is removable. The bow thwart consists of the front fixed part, the removable part and the back fixed part. A Brseč coat- of-arms (16 cm long and 12 cm wide) is inserted in a carving at the back fixed part of the thwart.</p> <p>The central thwart towards the bow is located at the frame F11; it is 1.28 m long, 23 cm wide and 3.2 cm thick at the front and back ends, and 4 cm wide in the middle. There is a hole, 10 cm in diameter, drilled in the middle for the mast.</p> <p>The central thwart towards aft is located at the frame F7; it is 1.25 m long, 23 cm wide and 3.3 cm thick at the front and back ends and 4 cm thick in the middle. The distance between the bow and stern thwart is 1.40 m.</p> <p>The stern thwart is composed of two wide side planks and two triangle shaped planks built in between the side thwart elements (this part is removable). The planks are 2 cm thick. The stern part of the thwart relies upon the two supports (deck beams), while the front part of the side thwarts connects to and relies on the central stern thwart.</p>
<p><b>Sails and rig</b></p>	<p><i>Describe in detail and provide the type (e.g. "al terzo", lateen, auric, Marconi, etc.) and other features of the sails, and of the fixed and running rigging</i></p> <p>The rigging consists of a mast, the main lugsail with the yard and boom, auxiliary sail – jib and standing and running rigging.</p> <p>The mast is situated approximately at one third length of the boat from the bow (1.74 m from the front edge of the stem). The mast is made of spruce (glued planks), 5.11 m in length (with truck), coated with clear varnish. The length of the lower mast to the hoop is 4.57 m. The mast diameter at the characteristic cross-sections are the following: 8.6 cm at the foot, 9.2 cm at the thwart, 9.3 cm at 1/4 length from the thwart, 9.0 cm at half length from the thwart, 8.5 cm at 3/4 length from the thwart, 7.4 cm immediately below the hoop, 6.3 cm at the hoop and 6.1 cm at the top. Mast foot is octagonal in cross-section, 8.6 cm in diameter. There is a truck installed at the top of the mast, 10 cm in diameter and 5 cm thick. Four profiled double cleats are installed on the mast, placed diagonally in relation to the boat buttocks.</p>

	<p>The yard, 5.94 m in length, is made of spruce (glued) and hollow in the middle in the smaller cross-section. The yard diameter at the characteristic cross-sections is the following: 6.4 cm at the bottom of the yard, 6.8 cm at 1/4 length, 6.6 cm at 1/3 length, 6.4 cm at half length, 5.6 cm at 3/4 length, and 4.3 cm at the top. The yard is coated with clear varnish.</p> <p>The boom, 4.09 m in length, is made of spruce (glued) and hollow in the middle in the smaller cross-section. The boom diameter at the characteristic cross-sections is the following: 5.6 cm at the fore part, 6.1 cm at 1/4 and 1/3 length, 5.8 cm at half length, 5.3 cm at 3/4 length, and 4.8 cm at the top. It is coated with clear varnish.</p> <p>The bowsprit, 1.67 m in length, made of spruce, has the following characteristic cross-sections: 5.4 cm at the foot, 6.3 cm next to the stem, 5.8 cm at half length from the stem and 4.8 cm at the top. Bowsprit foot is secured to the base fastened to the bow thwart. The bowsprit and the bowsprit foot base are coated with clear varnish.</p> <p>The boat is equipped with the main lugsail and the auxiliary jib. Both sails are made of canvas (180 g/m<sup>2</sup>). The lugsail has a surface of 14.3 m<sup>2</sup>. The jib has a surface of 3.9 m<sup>2</sup>. The sails are traditionally made with the sails hemmed with rope (luff line) with vertical sail panels. These sails are light beige without decorations. The lugsail has one reef.</p> <p>Standing rigging consists of two shrouds made of rope (braided hemp rope), 8 mm in diameter. Running rigging consists of a yard tackle, comprising the upper double block and the lower single block with an eye, tension rope, lugsail sheet made by means of the tackle consisting of an upper single block with an eye and the lower double block, and a jib halyard passing through a single block fastened to the mast hoop eye and the jib sheet with a shackle. All blocks are made of wood and brass.</p>
<p><b>Rudder and other steering elements</b></p>	<p><i>Describe the type and material of the rudder (e.g. tiller, wheel) and the other steering parts.</i></p> <p>The rudder is made of oak. The rudder blade, consisting of three planks, is 47 cm wide and 2 cm thick. The fore piece is flat, while the aft piece is mildly curved, so the blade is 44 cm wide at the very bottom (42 cm with curved edges). The rudder blade surface is approximately 0.33 m<sup>2</sup>, the rudder stretches to 0.35 m under the keel. The front piece extends to the top. The rudder stock is reinforced</p>

	<p>on both sides with two reinforcements. Immediately below the top of the rudder stock (5.5 cm from the top) there is a recess for inserting the tiller, 5 x 3 cm in cross-section. There are two stainless steel female fittings installed on the rudder at a 45 cm distance. The upper fitting is installed 25 cm from the top of the rudder stock (under the rudder stock reinforcement), and the lower is installed 74 cm from the top (and 74 cm from the bottom of the rudder). The rudder is placed by inserting a rod through the female fittings on the sternpost and rudder, thus forming an axis. The rod is made of stainless steel, 66 cm in length and 10 mm in diameter, with a decorative M19 nut at the top. The fittings are coated with brass-effect varnish. The 1.25 m long tiller is made of ash. It is curved in the shape of letter S (in vertical plane) and profiled (rounded edges); it ends with an almost oval hand gripping. The tiller is coated with clear varnish.</p>
<p><b>Other significant elements</b></p>	<p><i>E.g. inboard or outboard engine, changes made to the original hull, presence of incongruous elements, elements inserted for technical or regulatory reasons, etc.</i></p> <p>The boat was restored in her original form, except that during restoration modern tools were used and materials different from those used at the time the boat was built were coated with suitable coatings (e.g. stainless steel).</p> <p>The boat is driven by oars and sails, and an outboard engine if necessary.</p>
<p><b>Previous restorations</b></p>	<p><i>Indication and description of the previous restorations, if any, with indication of year, place/shipyard, replaced parts and work, if known</i></p> <p>It is not known exactly when the previous renovations were done. In the 1960s, several planks were restored. There were no reconstructions, except for regular maintenance. The boat remained true to the original.</p>



## Annexes to the technical descriptions

*Add a plan of the boat, or sketch, not important if made by CAD or laser scanner or by free hand, but mandatory with 3 views (side, front, top), and in addition 1 side view with sail/s and rig, views of details if important; all the views with the reference measures*

**Plan**

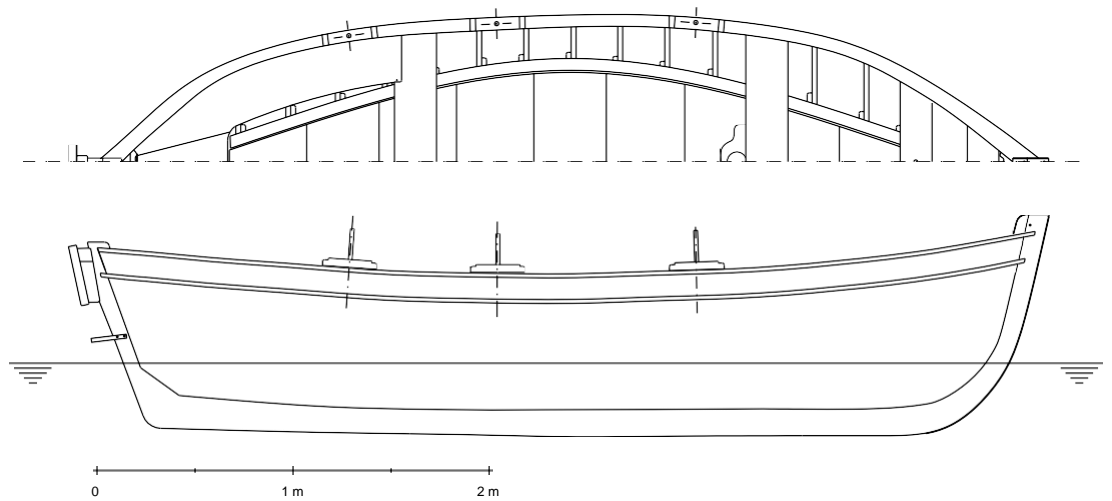

General arrangement

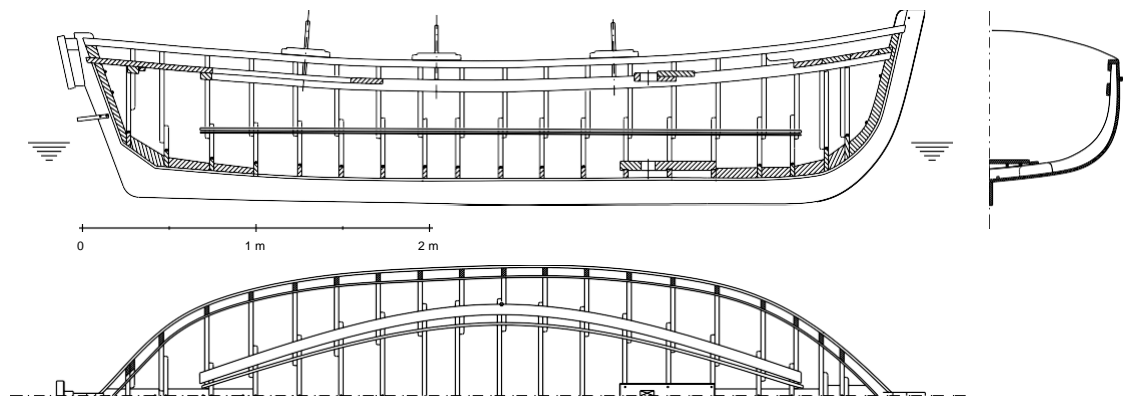

Construction drawings

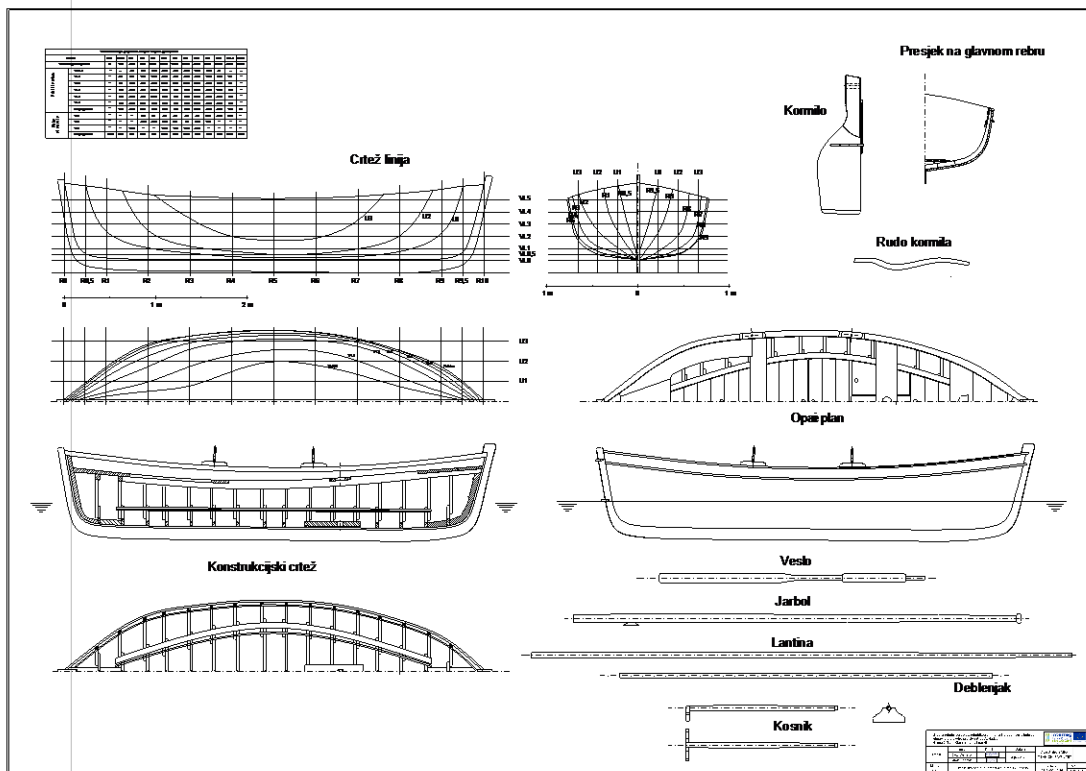
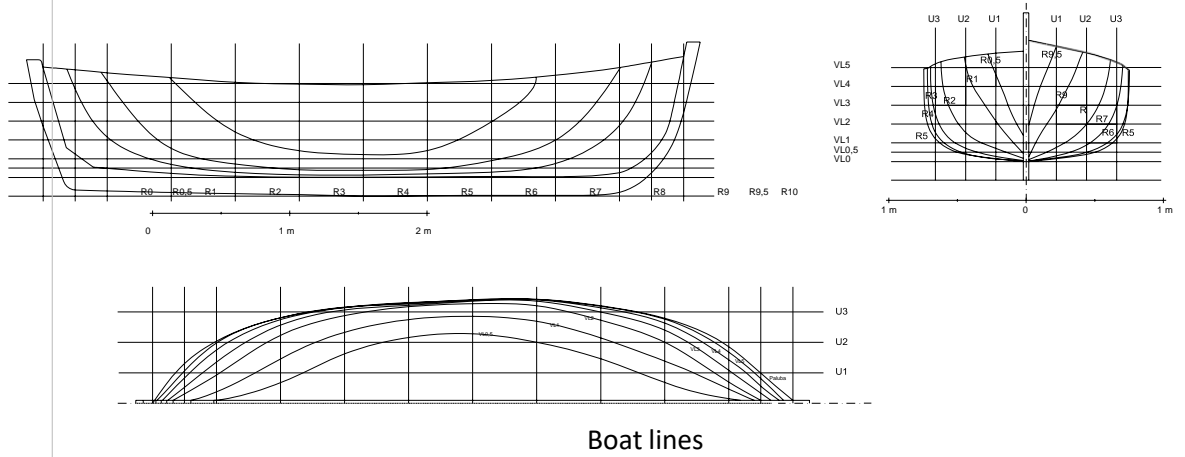

General arrangement, construction drawings, boat lines, rudder, tiller, oars, mast, bowsprit, yard, boo

<b>Name of the compiler</b>	Prof. Robert Mohović, PhD Igor Knapić, B.Sc.
<b>Date of compilation</b>	20. 09. 2021.

**Insert a reduced plan of the boat in the frame below**

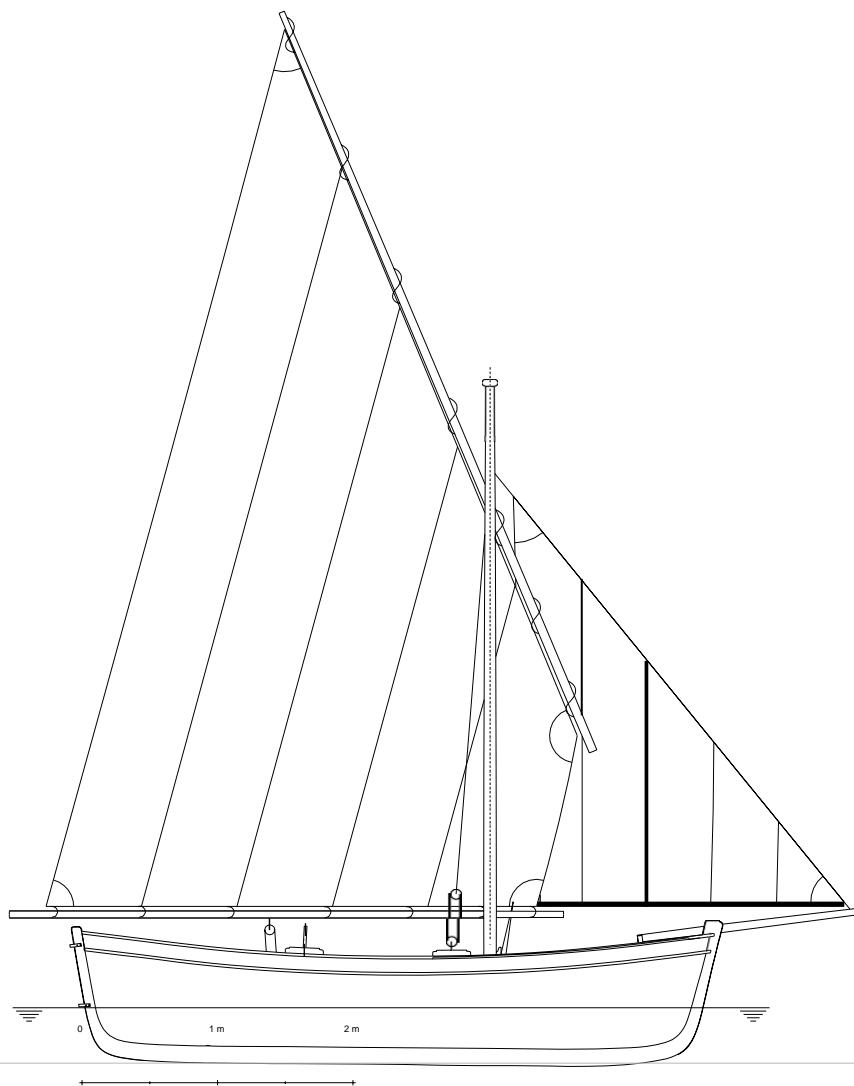

Insert a photo with a general view of the boat in the frame below



## LP - PRIMORJE-GORSKI KOTAR COUNTY

### Guc MD400



## Guc MD 400

### Section 1: boat data

	<p><b>Motivation for the selection of the boat</b></p> <p><i>(the grid has the function of identifying and exposing the reason that motivated the selection of this specific boat for restoration and documentation)</i></p>
<b>Ethnographic / cultural significance</b>	<p><i>E.g. does the boat represent traditional boat types (e.g. bragozzo, batana, etc.) or traditional fishing techniques, crafts, traditions?)</i></p> <p>The Kvarner guc represents a very valuable example of a restored traditional fishing boat, which will be used for demonstration sailing and which will represent the Ecomuseum Mošćenička Draga at festivals and regattas of traditional boats throughout Kvarner.</p>
<b>Historical significance</b>	<p><i>Is the boat related to any historical event? (include sports scores of particular relevance, personalities, etc.)</i></p> <p>The boat was built in 1970 in Lovran. The construction of the boat was ordered by the famous fishing family Babačić from Mošćenička Draga from the famous Lovran shipbuilder Ivan Nino Gasparinić. During this time, the boat was used for fishing with small fishing tools: spears, longlines, gillnets and pots. The current owner bought the boat in 2004 and used it for sport fishing, and the boat has been participating in festivals and regattas of traditional boats for the last ten years. The boat is moored in the port of Mošćenička Draga.</p>
<b>Technical / nautical significance</b>	<p><i>Do the boat has particular design solutions, or represents nautical types of boats (e.g. Olympic classes, series, etc...), or the work of some famous designer?</i></p> <p>The Kvarner guc has very slender lines as the boat was made as a rowing boat. The structural elements (keel, stem, sternpost, inner post and apron, floors and frames, bilge stringers, caprail and thwarts) are made of oak. The planking is made of spruce. The boat is open, deckless, fastened transversally with thwarts. The boat has a mast, a lugsail and jib. She is driven by oars and sails, and an outboard engine.</p>

<b>Replica</b>	<p><i>Is the boat an exact reproduction of a boat matching one of the above criteria?</i></p> <p>The boat MD 400 is not a replica, but an original boat from 1970.</p>
----------------	--

	<b>Identification data</b>
<b>Current boat name</b>	-
<b>Current register number (if registered)</b>	MD 400
<b>Current harbour / location</b>	Port of Mošćenička Draga
<b>Current owner</b>	
<b>Contact person / site</b>	<p><i>Indicate name and contact data (e.g. tel., email, others) in order to have if needed further infos about the boat</i></p>

	<b>Material data</b>
<b>Boat type / Traditional type</b>	<p><i>Name of the traditional typology (e.g. bragozzo, batana, also giving further specification related to place) or boat's type (e.g. cutter, dinghy, etc.)</i></p> <p>Guc (Kvarner guc)</p>
<b>Original function</b>	<p><i>Fishing, cargo or passengers transportation, leisure, sport,...</i></p> <p>The boat was used for fishing with small fishing tools: spears, longlines, gillnets and pots.</p>
<b>Rig</b>	<p><i>E.g. "al terzo", lateen, auric, etc.</i></p> <p>The boat has traditional rigging (one mast, lugsail and a jib).</p>

<b>Length</b>	4,81 m (length overall)
<b>Breadth</b>	1,54 m (breadth moulded)
<b>Draught</b>	0,34 m (from below the keel to the waterline of the hull)
<b>Tonnage or weight (if known)</b>	-
<b>Main materials and construction features</b>	<p><i>Indicate main construction features, e.g. hull materials and type of building (e.g. traditional wood building, oak wood, metal hull, etc.)</i></p> <p>The boat structural elements (keel, floors and frames, stem, sternpost, apron, inner post, bilge stringers, thwart risers, sheer strakes (external and internal), caprail and thwarts) are made of oak. Garboard strakes are made of oak, while the other planks are made of spruce.</p>

	<b>Historical data</b>
<b>Date / period of construction</b>	<i>E.g. 1935 / the 50s, etc</i> 1970.
<b>Construction place / shipyard or builder</b>	<i>Indicate the place or if unknown the area, and the name of shipyard or shipbuilder</i> The boat was built by Ivan Nino Gašparinić from Lovran.
<b>Designer, if any</b>	The shipbuilder Gašparinić himself.
<b>Historical presentation</b>	<p><i>Brief description of the life of the boat with reference to its original use and to events preceding the present restoration; indicate here also the previous names and register numbers, and previous owners, and restorations</i></p> <p>The construction of the boat was ordered by the famous fishing family Babačić from Mošćenička Draga from the famous Lovran shipbuilder Ivan Nino Gasparinić. During this time, the boat was used for fishing with small fishing tools: spears, longlines, gillnets and pots. The current owner bought the boat in 2004 and used it for sport fishing, and the boat has been participating in festivals and regattas of traditional boats for the last ten years. The whole time the boat was moored in the port of Mošćenička Draga.</p>



<b>Bibliography / links</b>	<p><i>Give a bibliography of published books or articles, or links to Internet resources (e.g. sites, social) on this specific boat (not about type or in general)</i></p> <p>-</p>
-----------------------------	---

## Section 2: technical description

<b>Metric data and shape of the hull</b>	<p><i>Indicate the salient measurements (in addition to those of length and width) and describe the general shape of the hull (e.g. sheer, length / width proportion, etc.)</i></p> <p>Guc is 4.81 m long, 1.54 m wide with a draught of 0.34 m and a height in the middle of 0.785 m. The boat has eighteen frames (frames F1 to F19), midships (theoretical main frame) is located between the frames F10 and F11.</p> <p>The ratio of length and breath <math>L/B=3.1</math>, the ratio of breath and draught <math>B/T=4.5</math>, the ratio of length and draught <math>L/T=14.1</math>, and the ratio of breath and height <math>B/H=1.96</math>.</p> <p>Guc is characterized by a very fine shape of the hull (slender lines) because the boat was designed as a rowing boat.</p>
<b>Structural parts (keel and frames)</b>	<p><i>Description of the structure of the boat, also indicating the number and measures of the frames, and other structural parts</i></p> <p>The boat structural elements (keel, floors and frames, stem, sternpost, apron, inner post, bilge stringers, thwart risers, sheer strakes (external and internal), caprail and thwarts) are made of oak. Garboard strakes are made of oak, while the other planks are made of spruce.</p> <p>Keel (made of oak) extends throughout the entire length of the boat, 4.21 m. The keel is made of two pieces joined vertically. It ends with an angle joint to the stemson at the bow. At the stern, the keel reaches the end of the boat, with the stern knee relying on it. The height of the keel along the entire length of the boat outside the hull ranges from 12.5 cm at the bow, 13 cm amidships and 15.5 cm at the stern (total height is greater by the height of the sheer strakes, 2 cm). The keel is slightly trapeze in cross-section, 4 cm thick on the inside (along the floors), 3.7 cm on the outside. The keel is protected by a stainless steel band, 2 cm wide and 3 mm thick.</p> <p>Stem and sternpost are made of oak. The stem is 6 to 7.5 cm wide outside the hull, 13 cm at the top, while the cross-section is 3.4 cm thick on the inner edge (at</p>

the place where it touches the apron) and it is 3.1 cm thick at the outer edge. The stem exceeds the caprail by 9 cm at the bow. The stem is fastened to the apron with stainless steel and brass bolts, 8 mm in diameter. The vertical part of the sternpost consists of two parts connected with Z scarf, overlapping by 18 cm, of which lower part turns into the stem knee that connects with the keel with a Z scarf, overlapping by 24 cm. The sternpost is 3 cm thick on the outer edge and widens slightly towards the inner post, exceeding the caprail by 4.3 cm. The sternpost is connected to the inner post by stainless steel and brass bolts, 8 mm in diameter.

The frames and floors are made of oak. The boat has eighteen frames (frames F1 to F19). The boat is constructed according to the three-piece frame system (floor, port and starboard frames), except the frames F1, F2, F18 and F19 which do not have floors, but have top timbers. Midships (theoretical main frame) is between the frames F10 and F11. The stern frames of the port and starboard sides (F3 to F10) are installed towards the aft in relation to the floors, while the bow frames of the port and starboard sides (F11 to F17) are installed forward in relation to the floors. Top timbers on the frames F1 and F2 are installed forward in relation to the frames. The floors are fastened to the keel with stainless steel bolts, 8 mm in diameter, that pass through the entire height of the floor and keel. They are made of one piece, 2.5 to 3.2 cm thick (most often 2.7 cm). The floors are 5.5 to 7 cm wide (high) in the middle (along the keel), and 5 to 5.5 cm at the ends (sides). Limbers (water passages) are cut in the floors on the lower side, to the port and starboard from the keel, with approximate cross-section 1.5 x 1 cm. The frames are also made of oak, 2.5 to 3.2 cm thick (most often 2.7 cm). The frames are as wide as the floors in the lower part (5 to 5.5 cm), while at the top they are 2.8 to 3 cm wide. The frames are fastened to the floors with stainless steel wood screws, 50 x 4 mm. The frames and floors overlap from 18 cm to 22 cm, and every connection is fastened with 3 screws.

The bilge stringers are made of oak and extend from the frames F2 and F3 to the frame F18 (exceeding it by a little). They are made in two pieces, connected at the F9 frame. They are 5 to 7 cm wide (mostly 7 cm) and 2.2 cm thick. They are fastened symmetrically on both sides of the frames, on the connections with the floors. Besides providing longitudinal strength, the bilge stringers serve as side delimiters of the limber boards.

The caprail, made of oak, is carried in the upper edge of the external and internal sheer strakes and fastened with stainless steel wood screws, 45 x 4 mm, to the

	<p>external and internal sheer strakes. The caprail (of the port and starboard sides) extends from bow to stern, 6.5 cm wide (6 cm at the bow and the stern) and 2.4 cm thick. Internal and external sheer strakes are made of oak. External and internal sheer strakes are made of oak and stretch from the stem to the sternpost. External sheer strakes are 8.5 cm wide at the bow, 12 cm in the middle and 10.5 cm at the stern, 1.8 cm thick. Internal sheer strakes are 3.7 cm to 4 cm wide and 1.8 cm thick.</p>
<p><b>Planking (external / internal)</b></p>	<p><i>Description of the planking, with measures, and type of waterproofing (e.g. caulking, epoxy, other)</i></p> <p>The planking consists of 9 planks (planks A to I), placed symmetrically on both sides, from the keel to the external sheer strake. The planks are 1.8 to 1.9 cm thick. The planks extend from the sternpost to the stem. Some planks are composed of several pieces. Garboard strakes, made of oak, are fitted along the keel, while the other planks are made of spruce. The planks are fastened with galvanized nails, 40 x 4 mm, to the floors, frames and top timber at the bow and stern. Nail heads are countersunk into the plank, while the holes are filled with epoxy and ground. The longitudinal seams between the planks and the heads on joints, including the stem and sternpost are caulked with hemp wool.</p>
<p><b>Deck and openings</b></p>	<p><i>Description of the deck and the number and size of the different opening</i></p> <p>The boat is open, deckless, with only two transverse thwarts and the thwarts at the bow and stern.</p> <p>The stern thwart (poop) is almost trapeze in shape, with a total length of 61 cm (longitudinally), 100.5 cm long on the internal side, ending at the bow with the top of the trapeze 7 cm wide. The bow thwart consists of four oak planks, front and back being fixed, while the other two are mutually connected and removable.</p> <p>The central thwart towards the bow is located at the frame F14; it is 1.37 m long, 21.5 cm wide and 2.8 cm thick at the front and back ends, and 3.8 cm wide in the middle. On the aft part of the thwart there is an element through which the mast passes. This element is made of oak and is fastened to the thwart at its bottom side with stainless steel bolts, 50 x 5 mm. The aft edge is rounded (narrower at the ends, wider in the middle) with a hole for the mast, 9.5 cm in diameter.</p> <p>The central thwart towards aft is located at the frame F7; it is 1.42 m long, 21.5 cm wide and 2.8 cm thick at the front and back ends and 3.8 cm thick in the middle. The distance between the thwarts is 1.48 m.</p>

	<p>The stern thwart is composed of two wide side planks and two mutually connected trapeze shaped planks built in between the side thwart elements (removable part). The planks are 2.2 cm thick. The stern part of the thwart relies upon the two supports (flat beams), while the front part of the side thwarts connects to and relies on the central stern thwart. The thwarts at the stern are 52.5 cm wide in the direction of the buttocks, and at the stern itself to the stern hook it is 7.5 cm wide. The side thwarts are 26 cm wide at the widest part. The thwarts are bolted to the thwart risers, i.e. flat beams. The removable part of the stern thwart is trapeze in shape, with 31 cm long base, 4.5 cm long top, 52.5 cm high and 3 cm thick. It consists of two planks mutually connected by two oak laths, 4.5 x 2.2 cm in cross-section.</p>
<p><b>Sails and rig</b></p>	<p><i>Describe in detail and provide the type (e.g. "al terzo", lateen, auric, Marconi, etc.) and other features of the sails, and of the fixed and running rigging</i></p> <p>The rigging consists of a mast, the main lugsail with the yard and boom, auxiliary sail – jib and standing and running rigging.</p> <p>The boat has one mast, situated approximately at one third length of the boat from the bow (1.65 m from the front edge of the stem). The mast is made of spruce (glued planks), 5.15 m in length (with truck), coated with clear varnish. The length of the lower mast to the hoop is 4.40 m. The mast diameter at the characteristic cross-sections are the following: 4.6 cm at the foot, 9.2 cm at the thwart, 9.2 cm at 1/4 length from the thwart, 8.2 cm at half length, 7.5 cm at 3/4 length, 6.8 cm immediately below the hoop, 5.5 cm at the hoop and 5 cm at the top. Mast foot is square in cross-section, 4.6 x 4.6 cm. The top of the mast is 70 cm long, with a truck installed, 10 cm in diameter and 5 cm thick. Three doublecleats are installed on the mast. One cleat is placed along the centreline in front of the mast, while the other two are placed transversally in relation to the boat centreline.</p> <p>The yard is 5.65 m long, hanging on the block at the mast hoop at approximately 1/3 length from the lower end. The yard is made of spruce. The yard diameter at the characteristic cross-sections is the following: 7.2 cm at the bottom of the yard, 7.5 cm at 1/4 length, 7.86 cm at 1/3 length, 7.3 cm at 3/4 length, 6.5 cm at the top. The yard is coated with clear varnish.</p> <p>The boom, 4.22 m in length, is made of spruce. The boom diameter at the characteristic cross-sections is the following: 7.2 cm at the fore part, 7.5 cm at</p>

	<p>1/4 length, 7.8 cm at 1/3 length, 7.3 cm at 3/4 length, 6.5 cm at the top. It is coated with clear varnish.</p> <p>The bowsprit, 1.61 m in length, made of spruce, has the following characteristic cross-sections: 7.4 cm at the foot, square shaped (approximately 46 cm long), then narrows down in height to 5.4 cm (narrowed to rest over the caprail), then widens in height to 7.5 cm next to the stem, then at half length from the stem it turns into a curved edged cross-section (5.5 cm in diameter), to 5.1 cm at the top to the hoop. Bowsprit foot is secured to the base by a stainless steel screw, 12 mm in diameter, and a screw eye instead of a nut to the bottom side of the thwart. At the top, the bowsprit has a hoop with eyes for attaching the jib. The bowsprit and the bowsprit foot base are coated with clear varnish.</p> <p>The boat is equipped with the main lugsail and the auxiliary jib. Both sails are made of canvas (180 g/m<sup>2</sup>). The lugsail has a surface of 14.2 m<sup>2</sup>. The sail is traditionally made with the sail hemmed with rope, except at the leeches, with vertical sail panel and one reef. The sail is light beige, without decorations. The jib has a surface of 3.1 m<sup>2</sup>. The sail is traditionally made with the sail hemmed at the fore part with rope and with vertical sail panels. The sail is light beige without decorations.</p> <p>Standing rigging consists of two shrouds made of stainless steel rope, 3 mm in diameter. The shrouds are tightened by braided rope made of three braids 8 mm in diameter (light beige polypropylene), with the tension rope passing through the fore tholepin bases and fastening around the thwart risers. Running rigging consist of a yard halyard, lugsail sheet made by means of the tackle, a jib halyard and a jib sheet. All roped used for running rigging are made of beige braided polypropylene. All blocks are made of wood and brass.</p>
<p><b>Rudder and other steering elements</b></p>	<p><i>Describe the type and material of the rudder (e.g. tiller, wheel) and the other steering parts.</i></p> <p>The rudder is made of oak. The rudder blade (consisting of three planks) is 38 cm wide and 2.6 cm thick. The fore and aft edges are flat. The height of the blade running surface is 72 cm, and the total height to the top of the rudder is 1.52 m. The rudder blade surface is approximately 0.27 m<sup>2</sup>. The rudder stretches to 41 cm under the keel. A horizontal lath, 5.5 cm wide, is installed at the bottom of the rudder blade, connecting the planks that made the rudder (edges are curved). The rudder stock is reinforced on both sides with two reinforcements, 59 cm long (aft end) and 65.5 cm long (at the fore part), 16.5 cm wide and 1.8 cm thick,</p>

	<p>fastened with stainless steel bolts, 45 x 5 mm (heads are countersunk). Immediately below the top of the rudder stock, at 4.5 cm, there is a recess for inserting the tiller, 5 x 2.6 cm in cross-section. There are two stainless steel male fittings installed on the rudder at a 54 cm distance. The upper fitting is installed 13 cm from the top of the rudder stock, extending 6.5 cm outside it. The lower fitting is installed 79 cm from bottom of the rudder (70 cm from the top of the rudder stock), it is 21.5 cm long (7 cm outside the rudder). The fittings are coated with brass-effect varnish. The 1.08 m long tiller is made of oak. It is profiled in the vertical and horizontal levels. The tiller is coated with clear varnish.</p>
<p><b>Other significant elements</b></p>	<p><i>E.g. inboard or outboard engine, changes made to the original hull, presence of incongruous elements, elements inserted for technical or regulatory reasons, etc.</i></p> <p>The boat was restored in her original form, except that during restoration modern tools were used and materials different from those used at the time the guc was built were coated with suitable coatings (e.g. stainless steel).</p> <p>The boat is driven by oars and an outboard engine, as well as sails.</p>
<p><b>Previous restorations</b></p>	<p><i>Indication and description of the previous restorations, if any, with indication of year, place/shipyard, replaced parts and work, if known</i></p> <p>It is not known when the previous renovations were done. There were no reconstructions, except for regular maintenance. The boat remained true to the original.</p>

## Annexes to the technical descriptions

*Add a plan of the boat, or sketch, not important if made by CAD or laser scanner or by free hand, but mandatory with 3 views (side, front, top), and in addition 1 side view with sail/s and rig, views of details if important; all the views with the reference measures*

**Plan**

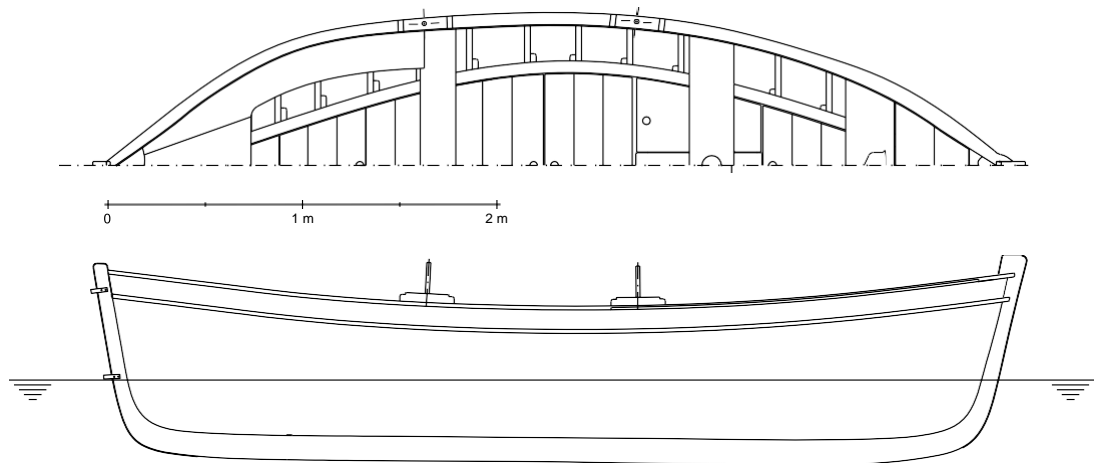

General arrangement

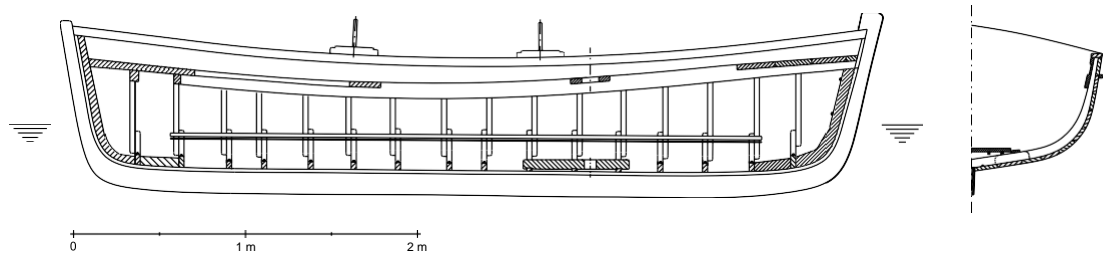

Construction drawings

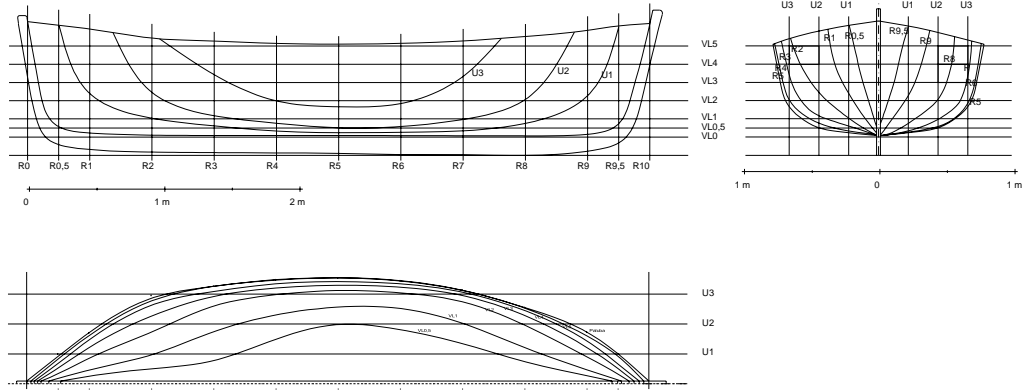

Boat lines

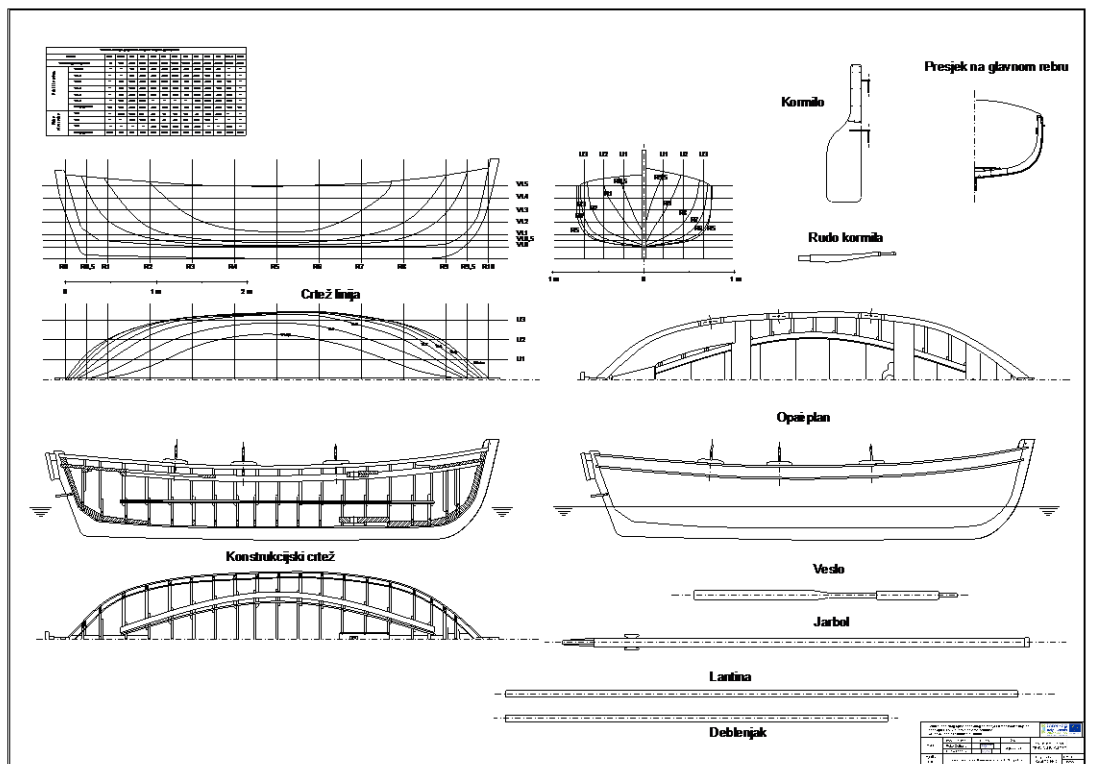

General arrangement, construction drawings, boat lines, rudder, tiller, oars, mast, bowsprit, yard, boom



Insert a reduced plan of the boat in the frame below

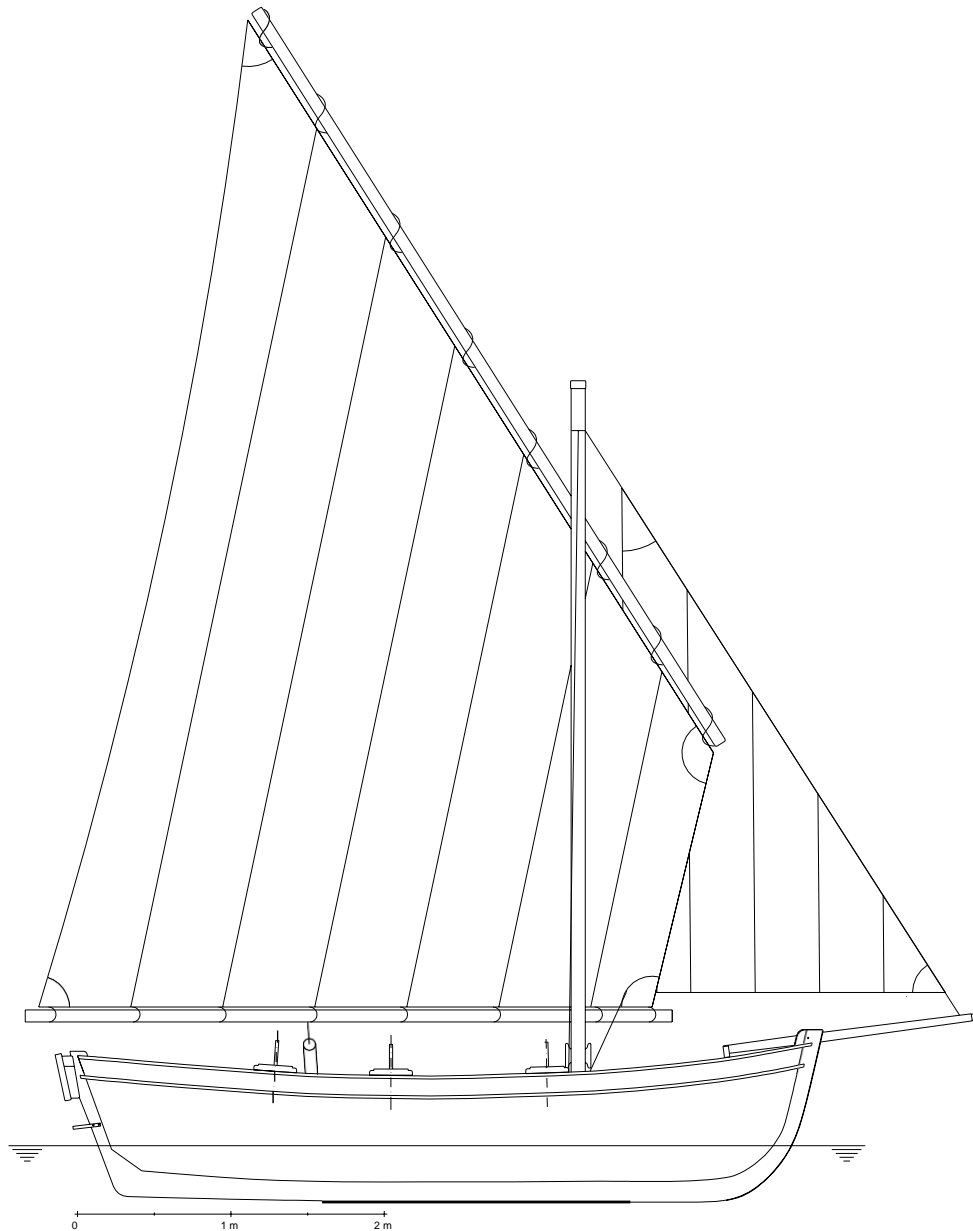

Insert a photo with a general view of the boat in the frame below



Name of the  
compiler  
Prof. Robert Mohović, PhD  
Igor Knapić, B.Sc.  
Date of compilation 20. 09. 2021.

## LP - PRIMORJE-GORSKI KOTAR COUNTY

### **Pasara *Diodata* (CS1079)**



## Pasara „Diodata“ CS 1079

### Section 1: boat data

	<p><b>Motivation for the selection of the boat</b></p> <p>(the grid has the function of identifying and exposing the reason that motivated the selection of this specific boat for restoration and documentation)</p>
<b>Ethnographic / cultural significance</b>	<p><i>E.g. does the boat represent traditional boat types (e.g. bragozzo, batana, etc.) or traditional fishing techniques, crafts, traditions?)</i></p> <p>Diodata (Gift from God) is a valuable example of a restored fishing boat, which is also a monument to Cres shipbuilders, who built the largest wooden ships in the 20<sup>th</sup> century that sailed the Adriatic. She is the oldest and largest wooden boat in the port of Cres, moored in a historic port next to the main square. She is a living exhibit of Cres shipbuilding history and the traditional way of life on this island as an intangible cultural heritage.</p>
<b>Historical significance</b>	<p><i>Is the boat related to any historical event? (include sports scores of particular relevance, personalities, etc.)</i></p> <p>The construction was ordered in the Cres shipyard Craglietto (today the Cres Shipyard), from the Burburan family from Dragozetíci, and after a few years she became the property of the Hržić family from Cres. Throughout history, the boat was used for fishing with a purse seiner, small seiners, with two other light boats equipped with kerosene lanterns (lights) also participating in fishing. In 1956, she was stolen by a group of Cres young men fleeing to Italy. She was found in the town of Rimini, returned to Cres and nationalized by the state. After a few years, she was returned to the Hržić family and was used for fishing, transporting people and sheep and visiting coastal olive groves.</p>
<b>Technical / nautical significance</b>	<p><i>Do the boat has particular design solutions, or represents nautical types of boats (e.g. Olympic classes, series, etc...), or the work of some famous designer?</i></p> <p>According to the shape of her hull and transom, the Diodata is a pasara kind of boat. Her bow reminds of gajeta, she is decked and has a low bulwark which reminds of leut. In the first half of the 20<sup>th</sup> century, the boats were often built with a round</p>

	stern and a vertical stem, such as <i>guc</i> , <i>gajeta</i> and <i>leut</i> . This boat, with her transom providing a larger running surface on the deck and bow shape common for the time of her construction, is an example of innovative design for that time. She is also one of the oldest large <i>pasara</i> boats on our coast of the Adriatic.
<b>Replica</b>	<i>Is the boat an exact reproduction of a boat matching one of the above criteria?</i> The boat CS 1079 is not a replica, but an original boat from 1931.

	<b>Identification data</b>
<b>Current boat name</b>	Diodata (Gift from God)
<b>Current register number (if registered)</b>	CS 1079
<b>Current harbour / location</b>	Port of Cres
<b>Current owner</b>	
<b>Contact person / site</b>	<i>Indicate name and contact data (e.g. tel., email, others) in order to have if needed further infos about the boat.</i> <div style="background-color: #cccccc; height: 40px; width: 100%;"></div>

	<b>Material data</b>
<b>Boat type / Traditional type</b>	<i>Name of the traditional typology (e.g. <i>bragozzo</i>, <i>batana</i>, also giving further specification related to place) or boat's type (e.g. cutter, dinghy, etc.).</i> Pasara
<b>Original function</b>	<i>Fishing, cargo or passengers transportation, leisure, sport,...</i> Throughout history, the boat was used for fishing with a purse seiner, small seiners, with two other light boats equipped with kerosene lanterns (lights) also participating in fishing. She was also used for transporting people and sheep and visiting the coastal olive groves.

<b>Rig</b>	<i>E.g. "al terzo", lateen, auric, etc.</i> The boat is equipped with traditional rigging and a lugsail.
<b>Length</b>	7,73 m (length overall)
<b>Breadth</b>	2,80 m (breadth moulded)
<b>Draught</b>	0,85 m (from below the keel to the waterline of the hull)
<b>Tonnage or weight (if known)</b>	-
<b>Main materials and construction features</b>	<i>Indicate main construction features, e.g. hull materials and type of building (e.g. traditional wood building, oak wood, metal hull, etc.).</i> Boat structural elements (keel, stem and sternpost, apron, inner post, floors and frames, bilge stringers, external planksheer strakes, deck stringers, planksheer, top timber, sheer strakes at the bulwark, caprail, deck beams) are made of oak. The planks are also made of oak and deck planks are made of larch.

	<b>Historical data</b>
<b>Date / period of construction</b>	<i>E.g. 1935 / the 50s, etc</i> 1931
<b>Construction place / shipyard or builder</b>	<i>Indicate the place or if unknown the area, and the name of shipyard or shipbuilder</i> The construction was ordered in the Cres shipyard Craglietto (today the Cres Shipyard) by the Burburan family from Dragozetići.
<b>Designer, if any</b>	Shipbuilder himself.
<b>Historical presentation</b>	<i>Brief description of the life of the boat with reference to its original use and to events preceding the present restoration; indicate here also the previous names and register numbers, and previous owners, and restorations</i> Throughout history, the boat was used for fishing with a purse seiner, small seiners, with two other light boats equipped with kerosene lanterns (lights) also participating in fishing. In 1956, she was stolen by a group of Cres young men fleeing to Italy. She was found in the town of Rimini, returned to Cres and nationalized by the state. After a few years, she was returned to the Hrzić family

	<p>and was used for fishing, transporting people and sheep and visiting coastal olive groves. She was designed to be driven by engine and sails. She was launched with an inboard 6 hp diesel engine Bolinder, later a 12 hp Lister engine was installed, then Perkins – IMT 39 hp. The mast and the sail were rarely used as they were unsuitable for fishing, so they were mainly used as auxiliary power.</p> <p>The previous owner was the Burburan family from Dragozetići. Then the boat became the property of the Hržić family. In the 1950s, the boat was briefly nationalized. Shortly afterwards, it was returned to its owners, the Hržić family.</p> <p>She was partially restored in 1993 in the Cres Shipyard when the deck and upper part of the planking was replaced.</p>
<b>Bibliography / links</b>	<p><i>Give a bibliography of published books or articles, or links to Internet resources (e.g. sites, social) on this specific boat (not about type or in general)</i></p> <p>-</p>

## Section 2: technical description

<b>Metric data and shape of the hull</b>	<p><i>Indicate the salient measurements (in addition to those of length and width) and describe the general shape of the hull (e.g. sheer, length / width proportion, etc.)</i></p> <p>The boat hull is 7.73 m long, 2.80 m wide (greatest width) with a draught of 0.85 m. The boat has 28 frames (frames from F1 to F28) and the zero frame F0. The middle of the boat (theoretical main frame) is located between the frames F14 and F15.</p> <p>The ratio of length and width <math>L/B = 2.8</math>, the ratio of width and draught <math>B/T = 3.3</math> and the ratio of length and draught <math>L/T = 9.1</math>.</p> <p>The boat, with her transom providing a larger running surface on deck and bow shape typical for the time when she was constructed, is an example of innovative design of that time.</p>
<b>Structural parts (keel and frames)</b>	<p><i>Description of the structure of the boat, also indicating the number and measures of the frames, and other structural parts.</i></p> <p>Boat structural elements (keel, stem and sternpost, apron, inner post, floors and frames, bilge stringers, external planksheer strakes, deck stringers, caprail, top timber, plank sheer, sheer strakes on the bulwark, deck beams) are made of oak. The planks are also made of oak and deck planks are made of larch.</p>

The keel (oak) stretches along the entire length of the boat and is 6.45 m long to the connection with the stem. At the stern, the keel reaches the end of the boat. The keel height (outside planks), almost equal along the entire length of the boat, is 19.5 to 20.5 cm together with the false keel. The propeller stern tube post, inner post and massive, apron and bow horizontal massive, and floors are bolted to the keel.

The stem, made of oak, is 1.28 m long (straight vertical part) and the stemson is 1.43 m long. The radius of curvature of the stem in the stemson is approximately 1.28 m. The stem width is 14.5 cm at the top, 13 cm at the level of the caprail, 13 cm in the scarf at the connection with the stemson, 13.5 cm in the stemson and 14 cm in the scarf at the connection with the keel. It is 6.8 cm thick at the top, 5.5 cm thick below the caprail, 4.1 cm in the scarf at the connection with the stemson, 7 cm in the stemson and 7 cm in the scarf at the connection with the keel. The top of the stem is rounded at the end, exceeding the caprail by 66 cm (53 cm from the elevation on the caprail). It is bolted to the apron by stainless steel 10 mm bolts. On its outer side, the stem is protected by a brass band, 1.35 m long. The stern ends in a transom made of oak, consisting of 5 planks. The transom width at the top is 1.65 m, it is 91 cm high and 4 cm thick. The transom is curved at the sides, defining the shape of the hull at the stern. It is bolted to the inner post by stainless steel 10 mm bolts. The zero frame is fastened to the transom.

The frames and floors are made of oak. The boat has 28 frames (frames F1 to F28) and the zero frame F0. The boat was originally made according to the 5-piece frame system (floor, port and starboard frames (bilge part of the frame and side frames)), but after restoration, the frames were reinforced, top timbers were added on the port and starboard sides. Midships (theoretical main frame) is located between the frames F14 and F15. The floors are made of oak, they are bolted to the keel by stainless steel 8 mm bolts, which pass through the entire height of the floor and keel. The floors are wider (higher) in the middle and they narrow down towards the ends. They are 4 to 5 cm thick. The width (height) of the floors in the middle ranges from 7 to 8 cm and from 6.5 to 7.5 on the sides. The frames are also made of oak, with 5 cm nominal thickness (4.5 to 5.3 cm). They are as wide in the lower part as the floors are at the sides, from 6.5 to 7.5 cm, while in the upper part (immediately below the stringer) they are 5.5 to 6 cm wide, a bit less at the very top. The frames were fastened to the floors with galvanized nails, 50 x 5 mm, which were replaced after restoration by stainless



	<p>steel 6 mm bolts. The floors and frames overlap, and in some places they consist of several parts and are mutually connected.</p> <p>The bilge stringers are made of oak and consist of two, and at the bow three parts in width, and several parts in length. They are 2.5 cm thick, except the bottom-most part of the stringers at the bow, which are 3 cm thick. Bilge stringer elements have a nominal thickness of 2.5 cm. They are fastened symmetrically on both sides of the frames, at the connections with the floors. They are fastened to each frame and floor with two galvanized nails, 70 x 4 mm (they are often nailed into the frames). Besides providing longitudinal strength to the boat, the stringers serve as side boundaries for the floors.</p> <p>The boat has 21 deck beam and halfbeam (DB1 to DB21) which carry the deck. Deck beams, made of oak, are slightly curved (they are hogging thus creating a slight camber on the deck). Nominal width (height) of the beams is 7 cm and their nominal thickness is 6 cm.</p> <p>The bulwark consists of bulwark stanchions, profiled massive wooden elements exceeding the plank sheers at the bow, external and internal sheer strakes and caprail. The height of the bulwark to the top of the caprail is 19 cm at the bow, 19 cm in the middle and 22 cm at the stern.</p> <p>The caprail, made of oak, relies on the upper edges of external and internal sheer strakes. It is fastened to the external and internal sheer strakes with galvanized nails, 70 x 4 mm. The caprail (both side and stern part) is 13 cm wide and 3.5 cm thick.</p>
<p><b>Planking (external / internal)</b></p>	<p><i>Description of the planking, with measures, and type of waterproofing (e.g. caulking, epoxy, other)</i></p> <p>The planking is made of 10 planks (planks from A to J) from the keel to the plank sheer. As a rule, the planks consist of several parts in length. The planks end at the stem, i.e. at the outer side of the transom. Garboard strakes are installed along the keel with two more planks made of oak, 2.8 cm thick, while the other planks, made of larch, are 2.2 cm thick. The planks are fastened to the floors, frames and stanchions with galvanized nails, 70 x 4 mm. Nail heads, i.e. screw heads were countersunk into the plank, and the holes were filled with epoxy and ground. The heads of the front parts of the planks are skewed in the longitudinal and transverse cross-section so they end up immediately to the stem. The heads of the aft part of stern planks end up on the aft edge of the transom. The heads</p>

	<p>of the forward and aft parts of the planks are vertical at the mutual connections. The longitudinal distance between the planks, including the heads on the connections, and the stem and sternpost were caulked with hemp wool.</p>
<p><b>Deck and openings</b></p>	<p><i>Description of the deck and the number and size of the different openings.</i></p> <p>The boat is decked along its entire length with one hatch (between the deck beams DB8 and DB11) and a deckhouse at the stern.</p> <p>Deck planks are fastened to the deck beams, specifically a central deck plank and 19 planks on the port and starboard sides at the widest part of the boat. The central deck plank is made of oak in three parts (bow part, the part between the deck hatch and the deckhouse and the stern part). The central deck planks are 22 cm wide and 3.5 cm thick; they are fastened to each deck beam with two nails, 70 x 4 mm. Other deck planks, made of larch, have a nominal width of 6 cm and thickness of 3 cm. The planks consist of several parts in length. Adjacent planks, consisting of several parts, partially overlap in length. They finish at their ends up to planksheers and follow the curvature of the sheers at boat sides or they finish vertically and end at the hatch coamings, deckhouse and into the stern planksheer. They are pressed against each other (carvel).</p> <p>The boat has one hatch with two covers. The fore part of the hatch is 2.90 m away from the aft part of the stem. The hatch coamings are made of oak, just like the beams and longitudinals. Hatch covers have plywood fitted on their upper side. The hatch is 96 cm long and 106.5 cm wide (inner hatch dimensions are 87 cm (longitudinal) and 97.5 cm (transverse)).</p> <p>The boat has a deckhouse at the stern which relies upon the coamings and stretches between the deck beams DB14 and DB18. The fore part of the deckhouse is 1.04 m away from the deck hatch. The length of the deckhouse coaming is 1.41 m, the width at the fore part is 1.31 m (on deck) and 1.30 m on the top of the coaming. The width of the coaming at the aft part is 0.90 m. The deckhouse itself is 1.09 m long at the bottom and 0.81 m under the roof top which is 0.90 m long. At the fore part it is 1.21 m wide (at the bottom) and 1.13 m under the roof top, which is 1.10 m wide. At the aft part, it is 0.97 m wide at the bottom and 0.89 m wide at the top under the roof top, which is 0.95 m wide. The height of the deckhouse (from the deck to the top of the roof) at the fore part is 1.20 m and at the aft part 1.21 m. The door at the aft part of the deckhouse cover the entire width of the wall between the vertical elements (light hole is 85 cm), and the height is 1.08 m.</p>

<p><b>Sails and rig</b></p>	<p><i>Describe in detail and provide the type (e.g. "al terzo", lateen, auric, Marconi, etc.) and other features of the sails, and of the fixed and running rigging.</i></p> <p>The rigging consists of the mast, standing rigging, lugsail with the yard and boom and the running rigging.</p> <p>The boat has a mast located approximately at 1/4 length from the bow (1.90 m). The mast is 7.98 m long, made of spruce (glued in 4 pieces). The mast diameter at characteristic cross-sections is the following: 13 cm at the foot, 13.2 cm at deck level, 14 cm at 1/4 length from the deck, 13.5 cm at half length, 12 cm at 3/4 length, 10.7 cm at hoop level (the hoop is 27 cm from the top of the mast), and 8.8 cm at the top. The mast foot is rectangular in cross-section, dimensions 9.5 cm x 9.5 cm with the height of 4 cm. There are 3 classic wooden double cleats installed at the mast, two at the sides and one in front. A hoop with eyes for attaching the rigging elements is situated 27 cm from the top of the mast. It is made of a stainless steel band, 6.4 cm wide and 6 mm thick. Its outer diameter is 11.5 cm and has 6 stainless steel eyes, 5 mm thick, welded on it (two in front, one on each side, two at the back (45° in relation to the buttocks) and one behind the mast.</p> <p>The yard length is 7.82 m; it attaches to the block on the mast hoop at approximately 1/4 length from the bottom end. The yard is made of spruce (glued from two parts). The yard diameter at the characteristic cross-sections is the following: 8 cm at the bottom of the yard, 8.7 cm at 1/3 length, 7.7 cm at 2/3 length and 5.7 cm at the top. A conical indentation is made 11 cm from the bottom part of the yard with the smallest diameter of 5.7 cm, which prevents the tension rope to slide from the upper front clew.</p> <p>The boom is 6.76 m long, made of spruce. The boom diameter at the characteristic cross-sections is the following: 8.5 cm at the fore part of the boom, 8.6 cm at the 1/4 length, 8.4 cm at half length, 7.9 cm at 3/4 length and 6 cm at the aft end. A conical indentation is made 7.5 cm from the bottom part of the boom with the smallest diameter of 6.5 cm, which prevents sliding of the tension rope from the lower front clew and the tension rope from the front part of the boom.</p> <p>Standing rigging consists of two shrouds and a mixed rope stay (combination of steel wire rope and synthetic rope), 16 mm in diameter. Running rigging consists of two yard sheets (inner tackle consisting of an upper double block with an eye and the lower double block and the outer tackle consisting of an upper single block with an eye and a lower single block), the main sail sheet made from a</p>
-----------------------------	--

	<p>tackle consisting of an upper double block, lower double block with an eye and the main sheet. All blocks are made of wood and brass.</p> <p>The boat is equipped with a lugsail, made of canvas (drabbet, 200 g/m<sup>2</sup>). The surface of the sail is 35.6 m<sup>2</sup>. The sail is traditionally made with the sails hemmed with rope (luff line), except at the leech, and one reef. The sail is light beige, without decorations. It is tied to the yard by a lace hitch or turns, and to the boom by rope turns. The ropes are made of braided polyester, beige in colour, 6 mm in diameter.</p>
<p><b>Rudder and other steering elements</b></p>	<p><i>Describe the type and material of the rudder (e.g. tiller, wheel) and the other steering parts.</i></p> <p>The boat has two rudders (one the usual size for this type and size of engine-driven boat and a larger one for sailing). The rudders are made of oak.</p> <p>The rudder blade width of the classic rudder when the boat is engine driven is 52 cm at its widest part, 37.5 cm at the narrowest part (on the fore side, the rudder blade is oval in order not to obstruct the propeller operation), and 40 cm at the bottom. The rudder blade consists of two planks fastened on the bottom side with a horizontal lath, 40 cm long and 4 cm wide. The rudder blade is 4 cm thick. The height of the running part is 0.70 m, and the overall height to the rudder stock is 1.76 m. The surface of the rudder blade is 0.32 m<sup>2</sup>. The rudder does not exceed the bottom of the keel. There are two metal fittings (male) on the rudder, made of stainless steel, at the mutual distance of 60 cm. The upper fitting is installed at 52.5 cm from the rudder top, and the lower fitting is at 117.5 cm from the top, i.e. 54.5 cm from the bottom of the rudder.</p> <p>The width of the sailing rudder blade is 54.5 cm at its widest part (on the fore side, the rudder blade is 5 cm indented in relation to the fore rudder stock line in order not to hit on the keel skeg and propeller shaft), and 40 cm at the bottom. The rudder blade has parallel fore and aft edges in its most part, while in the lower part it narrows down diagonally towards the bottom of the blade. The rudder blade consists of three planks fastened on the bottom with a horizontal lath, 40 cm long and 3.5 cm wide. The rudder blade is 4 cm thick. The height of the running part is 0.95 m, and the overall height to the rudder stock is 2.01 m. The surface of the rudder blade is 0.52 m<sup>2</sup>. The length of the rudder blade under the keel is 25 cm. There are two metal fittings (male) on the rudder, made of stainless steel, at the mutual distance of 60 cm. The upper fitting is installed at 52.5 cm from the rudder top, and the lower fitting is at 117.5 cm from the top, i.e. 78 cm from the bottom of the rudder. The fittings are made by welding</p>

	<p>stainless steel bands, 50 x 6 mm in cross-section, to the pins (they are partially curved around the pins).</p> <p>The boat has two tillers (one for the classical rudder and the other for the sailing rudder). The tillers are made of oak. The tiller for the classical rudder is 1.50 m long, and the tiller for the sailing rudder is 1.57 m long.</p>
<b>Other significant elements</b>	<p><i>E.g. inboard or outboard engine, changes made to the original hull, presence of incongruous elements, elements inserted for technical or regulatory reasons, etc.</i></p> <p>The boat was restored in her original form, except that during restoration modern tools were used and materials different from those used at the time the pasara was built were coated with suitable coatings (e.g. stainless steel).</p> <p>The boat is engine driven, except when sailing. Sometimes she is driven by oars.</p>
<b>Previous restorations</b>	<p><i>Indication and description of the previous restorations, if any, with indication of year, place/shipyard, replaced parts and work, if known</i></p> <p>She was partially reconstructed in 1993, when the deck and the upper planking were replaced in the Cres Shipyard. The boat remained faithful to the original except for adding the deckhouse.</p>

## Annexes to the technical description

Add a plan of the boat, or sketch, not important if made by CAD or laser scanner or by free hand, but mandatory with 3 views (side, front, top), and in addition 1 side view with sail/s and rig, views of details if important; all the views with the reference measures

Plan

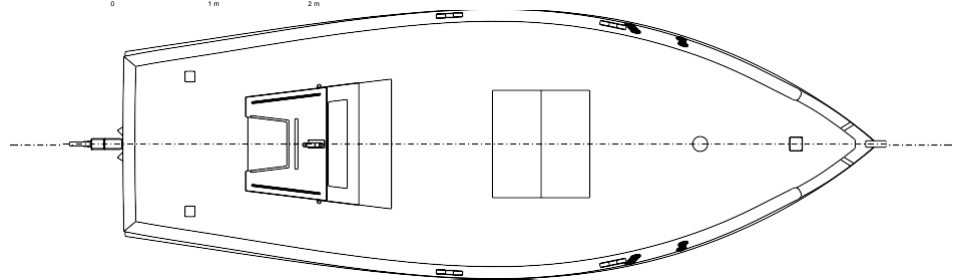
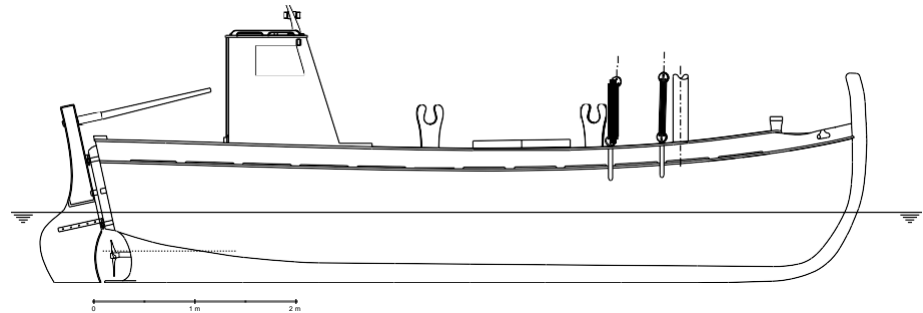

General arrangement

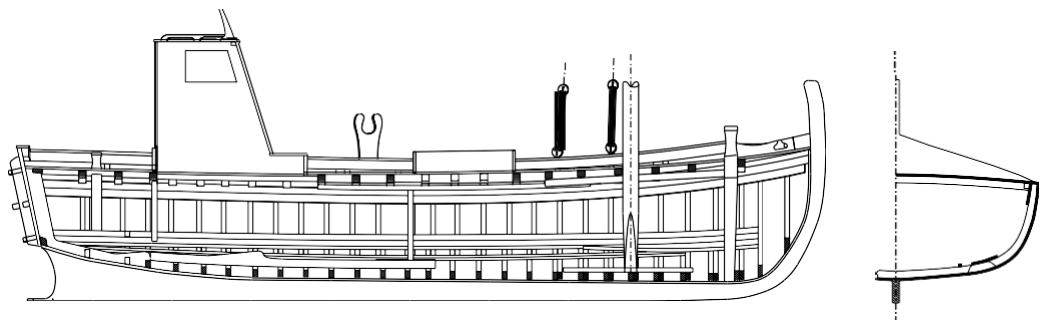

Construction drawings

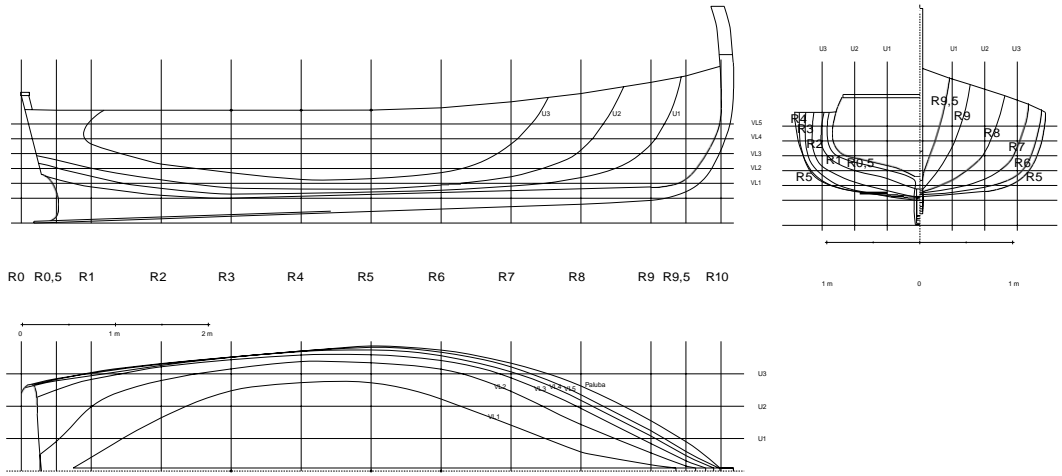

Boat lines

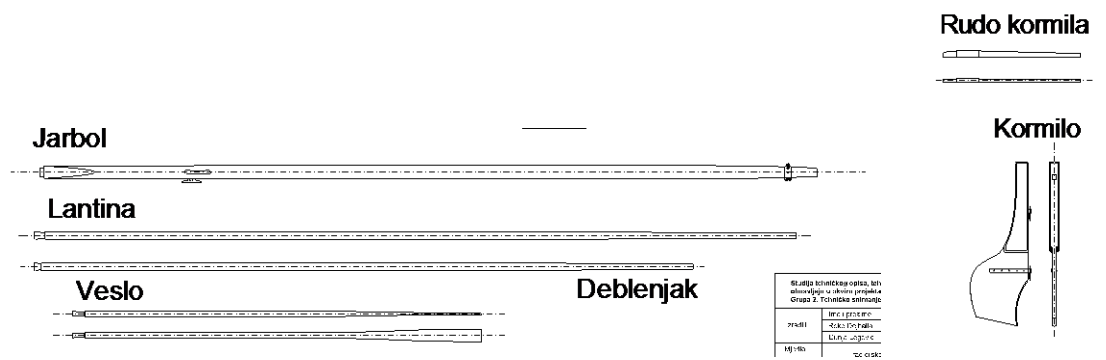

Mast, yard, boom, oars, rudder, tiller

Insert a reduced plan of the boat in the frame below

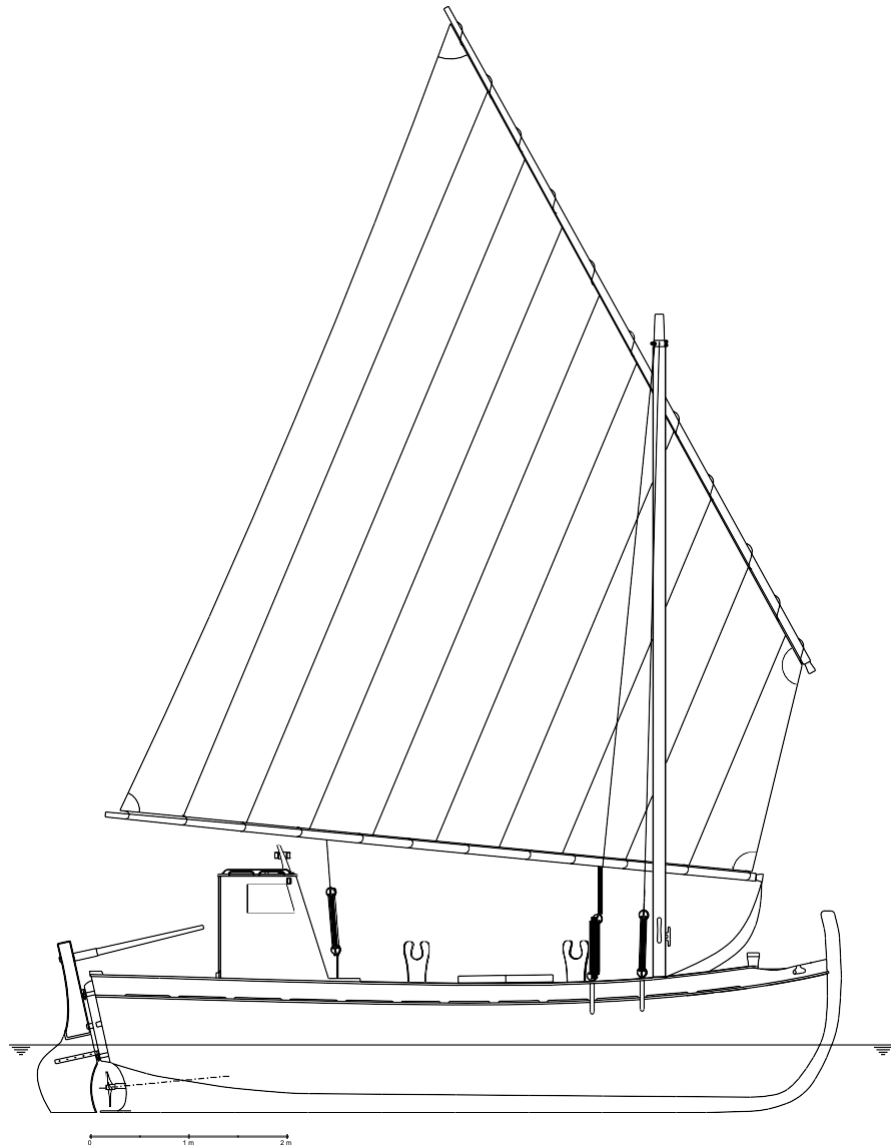



Insert a photo with a general view of the boat in the frame below



Name of the  
compiler  
Prof. Robert Mohović, PhD  
Igor Knapić, B.Sc.  
Date of compilation 20. 09. 2021

## LP - PRIMORJE-GORSKI KOTAR COUNTY

### ***Guc Maretin (OP3871)***



## Guc OP 3871

### Section 1: boat data

	<p><b>Motivation for the selection of the boat</b></p> <p><i>(the grid has the function of identifying and exposing the reason that motivated the selection of this specific boat for restoration and documentation)</i></p>
<b>Ethnographic / cultural significance</b>	<p><i>E.g. does the boat represent traditional boat types (e.g. bragozzo, batana, etc.) or traditional fishing techniques, crafts, traditions?)</i></p> <p>This guc is a valuable example of a restored traditional boat that will be used for demonstration sailing and with which the association Lovranska Lantina from Lovran will present itself at festivals and regattas of traditional boats throughout Kvarner.</p>
<b>Historical significance</b>	<p><i>Is the boat related to any historical event? (include sports scores of particular relevance, personalities, etc.)</i></p> <p>Guc was built in 1945 in Kraljevica by shipbuilder Tomo Bobuš. The boat was used in the Vinodol Channel for small fishing and recreational purposes. The owner of the guc is Ivanka Mladenčić from Viškovo, who bought the boat in Crikvenica.</p>
<b>Technical / nautical significance</b>	<p><i>Do the boat has particular design solutions, or represents nautical types of boats (e.g. Olympic classes, series, etc...), or the work of some famous designer?</i></p> <p>The guc has slender lines. Structural elements (keel, stem, sternpost, apron and inner post, floors, frames, stringers, caprail and thwarts) are made of oak. The planking is made of spruce. The boat has a bow deck.</p>
<b>Replica</b>	<p><i>Is the boat an exact reproduction of a boat matching one of the above criteria?</i></p> <p>The boat OP 3871 is not a replica, but an original boat from 1945.</p>
	<p><b>Identification data</b></p>
<b>Current boat name</b>	Maretin

<b>Current register number (if registered)</b>	OP 3871
<b>Current harbour / location</b>	Port Opatija – Ika
<b>Current owner</b>	[REDACTED]
<b>Contact person / site</b>	<i>Indicate name and contact data (e.g. tel., email, others) in order to have if needed further infos about the boat</i> [REDACTED]

	<b>Material data</b>
<b>Boat type / Traditional type</b>	<i>Name of the traditional typology (e.g. bragozzo, batana, also giving further specification related to place) or boat's type (e.g. cutter, dinghy, etc.)</i> Guc
<b>Original function</b>	<i>Fishing, cargo or passengers transportation, leisure, sport,...</i> The boat was used in the area of the Vinodol Channel for small scale fishing and recreational purposes.
<b>Rig</b>	<i>E.g. "al terzo", lateen, auric, etc.</i> The boat is equipped with traditional rigging (one mast, lugsail and jib).
<b>Length</b>	5,05 m (length overall)
<b>Breadth</b>	1,63 m (breadth moulded)
<b>Draught</b>	0,35 m (from below the keel to the waterline of the hull)
<b>Tonnage or weight (if known)</b>	-
<b>Main materials and construction features</b>	<i>Indicate main construction features, e.g. hull materials and type of building (e.g. traditional wood building, oak wood, metal hull, etc.)</i> Boat structural elements, keel, floors and frames, stem and sternpost, apron, inner post, bilge stringers, thwart risers and thwarts, deck beams, sheer strakes (external and internal) and the caprail are made of oak, while the hull planks are made of spruce, except for the garboard strakes which are made of oak.

	<b>Historical data</b>
<b>Date / period of construction</b>	<i>E.g. 1935 / the 50s, etc</i> 1945.
<b>Construction place / shipyard or builder</b>	<i>Indicate the place or if unknown the area, and the name of shipyard or shipbuilder</i> The boat was built by Tomo Bobuš from Kraljevica.
<b>Designer, if any</b>	The shipbuilder Bobuš himself.
<b>Historical presentation</b>	<i>Brief description of the life of the boat with reference to its original use and to events preceding the present restoration; indicate here also the previous names and register numbers, and previous owners, and restorations</i> Guc was built in 1945 in Kraljevica by the shipbuilder Tomo Bobuš. The boat was used in the Vinodol Channel for small fishing and recreational purposes. The owner of the guc is Ivanka Mladenčić from Viškovo, who bought the boat in Crikvenica, and is now used by her son-in-law Zoran Srdić, who participates in regattas of traditional boats.
<b>Bibliography / links</b>	<i>Give a bibliography of published books or articles, or links to Internet resources (e.g. sites, social) on this specific boat (not about type or in general)</i> -

## **Section 2: technical description**

<b>Metric data and shape of the hull</b>	<p><i>Indicate the salient measurements (in addition to those of length and width) and describe the general shape of the hull (e.g. sheer, length / width proportion, etc.)</i></p> <p>Guc is 5.05 m long, 1.63 m wide with a draught of 0.35 m and a height of 0.75 m. The boat has nineteen frames (frames F1 to F19), midships (theoretical main frame) is located between the frames F10 and F11.</p> <p>The ratio of length and breadth <math>L/B=3.1</math>, the ratio of breadth and draught <math>B/T=4.7</math>, the ratio of length and draught <math>L/T=14.4</math>, the ratio of length and height <math>L/H=6.7</math>, and the ratio of breadth and height <math>B/H=2.2</math>.</p> <p>Guc is characterized by her fine hull shape.</p>
--	---

<p><b>Structural parts (keel and frames)</b></p>	<p><i>Description of the structure of the boat, also indicating the number and measures of the frames, and other structural parts</i></p> <p>Boat structural elements (keel, floors and frames, stem and sternpost, apron, inner post, bilge stringers, thwart risers and thwarts, deck beams, sheer strakes (external and internal) and the caprail are made of oak, while the hull planks are made of spruce, except for the garboard strakes which are made of oak.</p> <p>Keel, 4.30 m long (oak) extends throughout the entire length of the boat (to the stemson), at the stern it reaches the end of the boat and ends in a curvature with a radius of approximately 13 cm. The keel is 14 cm high at the bow to the stemson, 15 cm amidships and at the stern, and it is 4.8 cm thick. The floors are bolted to the keel, including the apron, sternpost, inner post and the stern horizontal body.</p> <p>The stem and sternpost are made of oak. The length of the flat (vertical) part of the stem is 0.79 m, and the stemson 0.47 m. The radius of the stemson curvature is approximately 90 cm. The width of the stem outside the hull is 8.5 to 9.5 cm, and 16 cm at the top together with the apron. It exceeds the caprail by 5.5 cm. It is bolted to the apron with 10-mm bolts. The sternpost is vertical, 0.86 m in length. At its bottom end, it relies directly on the keel. The sternpost is 10 to 12.5 cm wide outside the hull, 4.5 cm thick on the inner side and 4.3 cm on the outer side. It exceeds the caprail by 3.5 cm, and the overall width at the top together with the inner post is 21 cm. It is bolted to the inner post by stainless steel 10 mm bolts.</p> <p>The floors and frames are made of oak. The boat has 19 frames (frames F1 to F19) and was built according to the three-piece frame system (floors, port and starboard side frames), except for the frames F1, F2, F18 and F19 which do not have floors. The distance between the frame lines is different, ranging from 20.5 cm to 27 cm (most frequently between 22.5 and 25.5 cm). Midship (theoretical main frame) is located between the frames F10 and F11. The stern frames on the port and starboard side (F1 to F10) are installed towards the stern in relation to the floors, while the bow frames on the port and starboard side (F11 to F19) are installed towards the aft in relation to the floors. The floors are bolted to the keel by stainless steel bolts, 10 mm in diameter, which pass through the entire height of the floor and keel. They are made of one piece, 2.7 to 3.7 cm thick (most often 3.0 to 3.5 cm). The floors are wider (higher) in the middle and they narrow down towards their ends. The frames F1 and F2 do not have floors</p>
--	---

	<p>and they rely directly to the stern body to which they are fastened (frames are not mutually fastened).</p> <p>The bilge stringers are made of oak, extending from the frame F2 to F18 along the floor edges, 5 cm wide and 1.5 cm thick. They consist of two laths connecting at the vertical connection at the frame F10 on both sides. They are fastened to each frame with a stainless steel wood screw, 40 x 4 mm (at the connection, each part, fore and aft, is fastened to the frame with two screws). Besides achieving the longitudinal strength, these stringers serve as the side floor boundaries.</p> <p>The caprail, made of oak, is 1.8 cm thick. It relies on the upper edges of the external and internal sheer strakes and the bow deck beam and is fastened to them with stainless steel wood screws, 40 x 4 mm. Both caprails (port and starboard) consist of two parts connected at the frames F13 and F14. They are mutually connected by a butt joint. The caprail width at the bow is 9 cm (ending sharply at the bow), then it widens towards the end of the deck to 16 cm, and amidships and at the stern it is 6 cm wide. The caprail is thicker than the deck planks so its plane is 5 mm above the deck plane. The ends (heads) of the fore caprail parts end around the stem on the central deck plank and at the stern on the sternpost.</p> <p>The boat has six deck beams at the bow, made of oak, which carry the deck. The deck beams are slightly bent (they are hogged thus making a camber of 4.6 cm, which reduces towards the bow). Deck beams extend between the external sheer strakes. They are profiled at the bottom and have a nominal thickness of 3 cm and height of 5 to 5.5 cm.</p>
<p><b>Planking (external / internal)</b></p>	<p><i>Description of the planking, with measures, and type of waterproofing (e.g. caulking, epoxy, other)</i></p> <p>The planking is made of 8 planks (planks A to H) symmetrically on both sides from the keel to the external sheer strake. The planks are 1.7 cm thick. Garboard strakes, made of oak, are fitted along the keel, while the other planks are made of spruce. The planks are made of several pieces. They are of different widths (from 11 to 15.5 cm) and they narrow down at the bow and the stern. The planks end at the stem and sternpost, except for the garboard strakes, which end in a sharp angle in the stemson and at the stern in the sternpost. The planks are fastened to the floors and frames with galvanized nails, 50 x 3.1 mm, and screws, 40 x 4 mm.</p>

<p><b>Deck and openings</b></p>	<p><i>Description of the deck and the number and size of the different openings</i></p> <p>The boat is decked up to approximately 1/3 of her length, she has thwarts at the stern (one transverse and two longitudinal) and one removable transverse thwart amidships.</p> <p>The deck consists of the central deck plank and 9 planks to the port and to the starboard side, respectively. Deck planks are made of ash. The deck is made by fitting deck planks on a 6-mm thick water-proof plywood which was placed on the deck beams. The central plank extends from the stem to the end of the deck, i.e. the breakwater fastened to the deck beam DB6 (on the frame F14). The central deck plank is made of oak, it is 14.5 cm wide and 1 cm thick, 5 mm higher than the other deck planks. It is fastened with two stainless steel wood screws, 40 x 4 mm, to the deck beams. The deck planks are 6 cm wide and 5 mm thick, mutually pressing against one another without any particular bonding; they are fastened to the deck beams with two stainless steel wood screws, 30 x 4 mm. The deck planks end towards the middle of the boat to the central deck plank, and to the caprail at the sides; they follow the curvature of the caprail, ending at the back part into a transverse element installed to the breakwater.</p> <p>A transverse and two longitudinal thwarts are installed at the stern with elliptic ending and a stern part of the thwart. The thwarts rely on thwart risers. The transverse thwart is 1.50 m long (extending between the frames), 23.5 cm wide and 3 cm thick, with rounded edges. Stern longitudinal thwarts are 25.5 to 27.5 cm wide and 3 cm thick. The distance between the thwarts forward is 90.5 cm and aft 34.5 cm. Longitudinal thwarts extend from the transverse thwart (they overlap by 3.5 cm) to the stern inner post.</p> <p>An auxiliary removable thwart, 140 cm long, 19.5 cm wide and 2.8 cm thick, is foreseen amidships. The thwart relies on the girder installed on the thwart risers on the frames F12 and F13, fastened to the thwart risers with two stainless steel wood screws, 50 x 4 mm. All thwarts have a granulated final coating as an anti-slip layer.</p>
<p><b>Sails and rig</b></p>	<p><i>Describe in detail and provide the type (e.g. "al terzo", lateen, auric, Marconi, etc.) and other features of the sails, and of the fixed and running riggin</i></p> <p>The boat rigging consists of the mast, bowsprit, standing rigging, a lugsail with the yard and boom, jib and running rigging.</p>



The boat has one mast, 5.07 m long (the lower mast to the hoop is 4.61 m long) located approximately at 1/3 length of the boat from the bow. The mast is made of spruce (glued). The mast diameter at characteristic cross-sections is the following: square cross-section to the foot 6.7 x 6.7 cm, 9.2 cm at deck level (reinforcement), 8.9 cm immediately above, 8.6 cm at 1/4 length, 8.4 cm at half length, 7.1 cm at hoop height, 6.1 cm above the hoop and 5.4 cm at the top. Four wooden cleats for fastening the halyard, luff, etc, were installed at the lower part of the mast, immediately above deck level.

The yard is 6.60 m long, made of spruce (glued). The yard diameter at characteristic cross-sections is the following: 7 cm at the bottom of the yard, 7 cm at 1/4 length, 7.1 cm at 1/3 length, 7 cm at 1/2 length, 5.9 cm at 3/4 length and 4 cm at the top. The lower and upper ends of the yard are slightly curved.

The boom is 4.55 m long, made of spruce (glued). The boom diameter at characteristic cross-sections is the following: 6.1 cm at the fore part, 6.3 cm at 1/4 length, 6.2 cm at 1/2 length, 6.1 cm at 3/4 length and 5.2 cm at the end. The fore and aft parts of the boom are slightly curved.

The bowsprit is made of oak, 80.5 cm long. There is a stainless steel fitting installed at the top (coloured in brass colour), 7.3 cm long and 2 mm thick, with two eyes welded on the upper side (for the forestay and jib) and an eye on the lower side (for the forestay).

The boat is equipped with the main lugsail and the auxiliary jib. Both sails are made of canvas (drabbet, 200 g/m<sup>2</sup>). The sails are light beige without any decorations. The surface of the main sail is 10.9 m<sup>2</sup>, while the surface of the auxiliary sail is 4.2 m<sup>2</sup>. The sails are traditionally made with the sails hemmed with rope (luff line), except at the leech, and the lugsail has one reef.

The standing rigging consists of the stay, two shrouds and a forestay. They are made of wire line (stainless steel painted white), 5 mm in diameter. The running rigging consists of the yard tackle, consisting of a single block with an eye, tension rope, lugsail sheet made from a block attached at the upper end to the boom and at the lower end to the fitting on the frame F7, and the jib tackle which passes through the single block attached by a shackle to the fore eye of the mast hoop and the jib sheet. All tackles are made of wood and brass.

<p><b>Rudder and other steering elements</b></p>	<p><i>Describe the type and material of the rudder (e.g. tiller, wheel) and the other steering parts.</i></p> <p>The rudder is made of oak. The rudder blade width at the widest part is 51 cm, 30 cm at the bottom, narrowing down towards its top and turning into the rudder stock. It is 2.2 cm thick. The rudder blade consists of three planks, 19, 20 and 12 cm wide (the blade narrows down towards the bottom). The height of the running part of the blade is 0.75 m, and the overall height to the top of the rudder is 1.25 m. The rudder blade surface is 0.33 m<sup>2</sup>. The length of the rudder blade under the keel is 13 cm. Rudder stock is reinforced on both sides with reinforcements (band) 44.5 cm long, 10 cm wide and 2 cm thick. The overall rudder thickness is 6.9 cm. There are two brass male fittings on the rudder at a mutual distance of 34 cm. The upper fitting is installed at 28.5 cm from the top of the rudder stock and the lower at 67 cm from the top. The tiller is made of oak, 1.24 m long, 3.2 to 6.7 cm wide and 3.5 to 6.3 cm thick (curved and profiled, massive at the aft part, ending in an almost spherical shaped expansion, 5.7 cm in diameter, at the fore part).</p>
<p><b>Other significant elements</b></p>	<p><i>E.g. inboard or outboard engine, changes made to the original hull, presence of incongruous elements, elements inserted for technical or regulatory reasons, etc.</i></p> <p>The boat was restored in her original form, except that during restoration modern tools were used and materials different from those used at the time the guc was built were coated with suitable coatings (e.g. stainless steel).</p> <p>The boat is driven by oars and sails, and an outboard engine if necessary.</p>
<p><b>Previous restorations</b></p>	<p><i>Indication and description of the previous restorations, if any, with indication of year, place/shipyard, replaced parts and work, if known</i></p> <p>It is not known exactly when the previous renovations were done. There were no reconstructions, except for regular maintenance. The boat remained true to the original.</p>

## Annexes to the technical description

Add a plan of the boat, or sketch, not important if made by CAD or laser scanner or by free hand, but mandatory with 3 views (side, front, top), and in addition 1 side view with sail/s and rig, views of details if important; all the views with the reference measures

### Plan

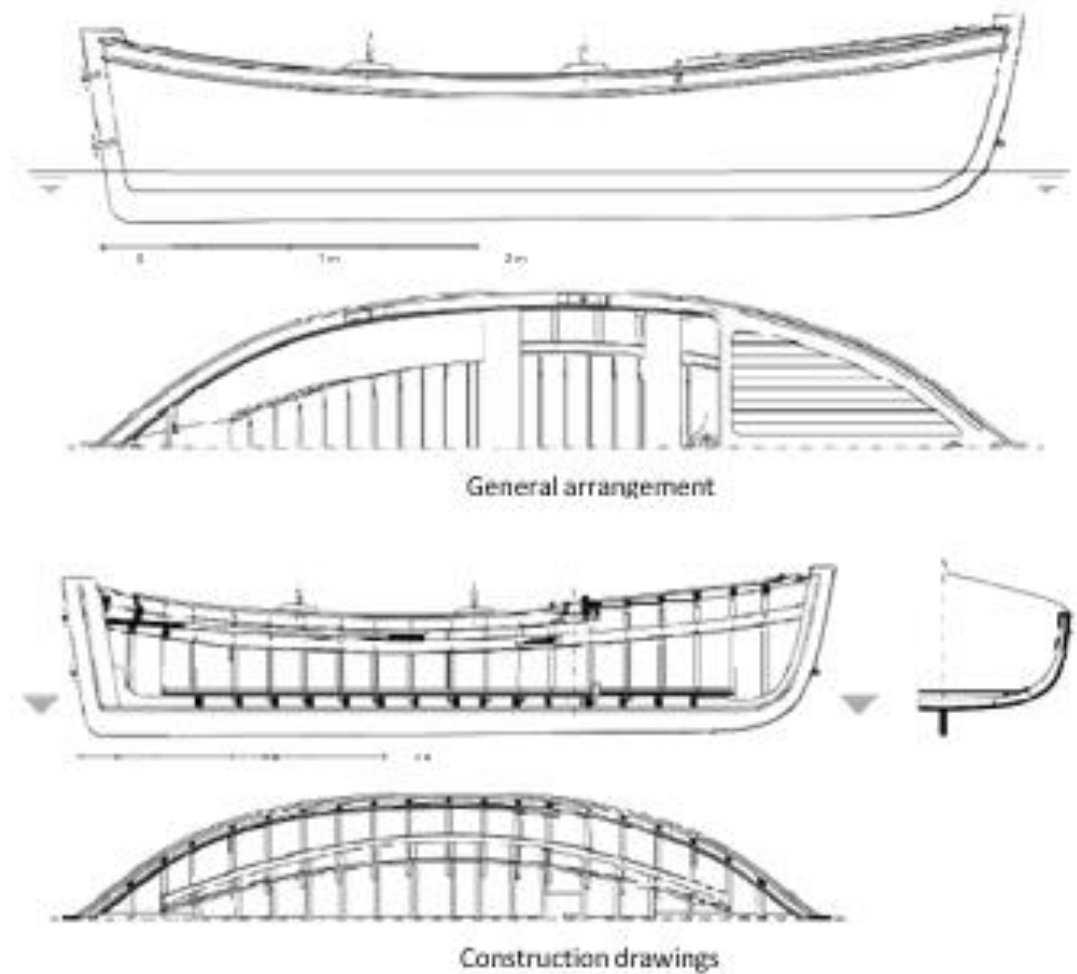

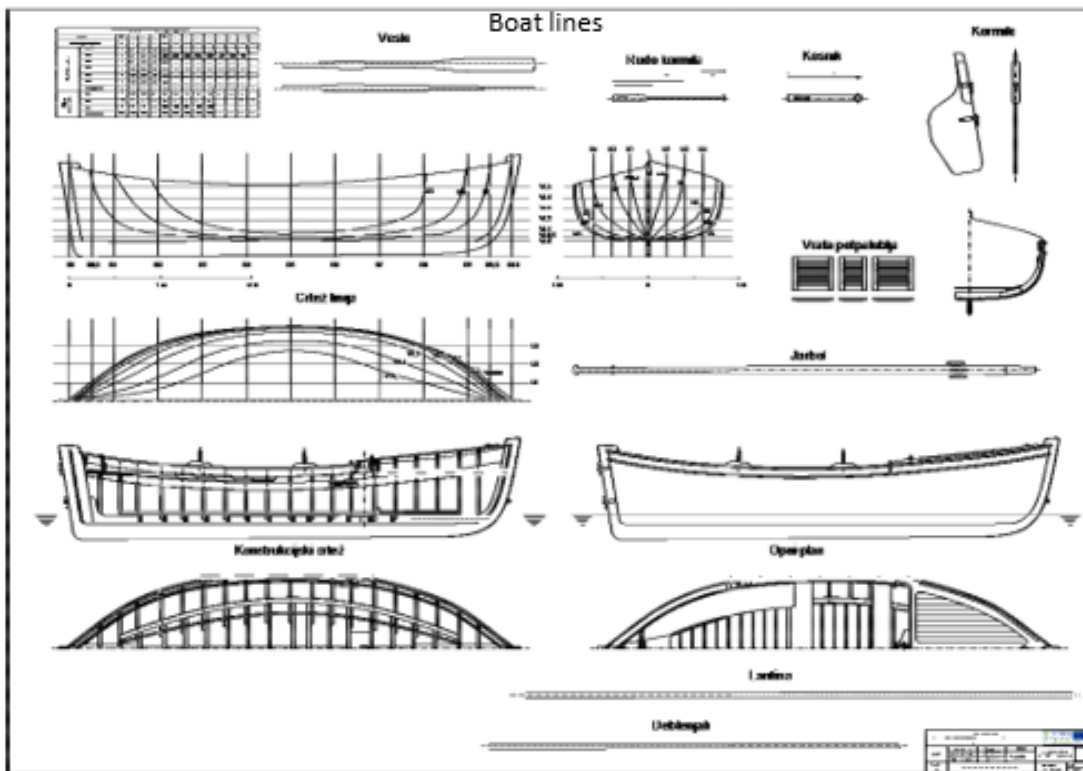
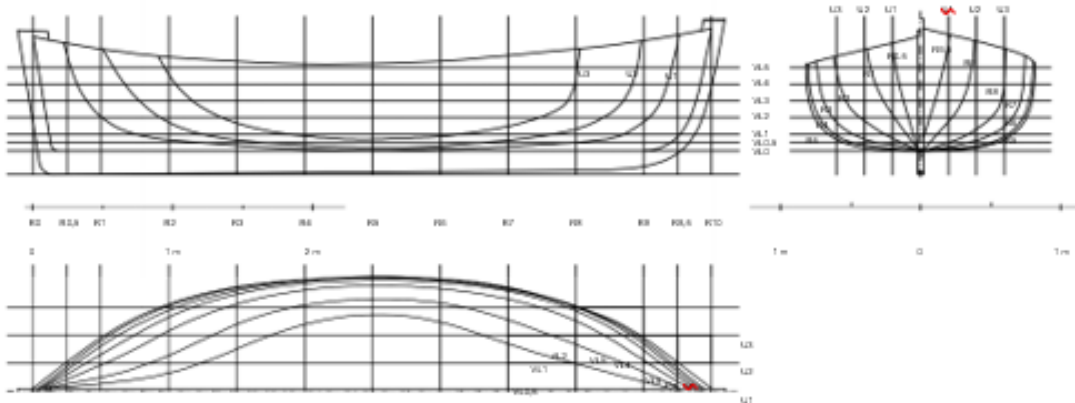

General arrangement, construction drawings, boat lines, rudder, tiller, oars, mast, bowsprit, yard, boom

Insert a reduced plan of the boat in the frame below

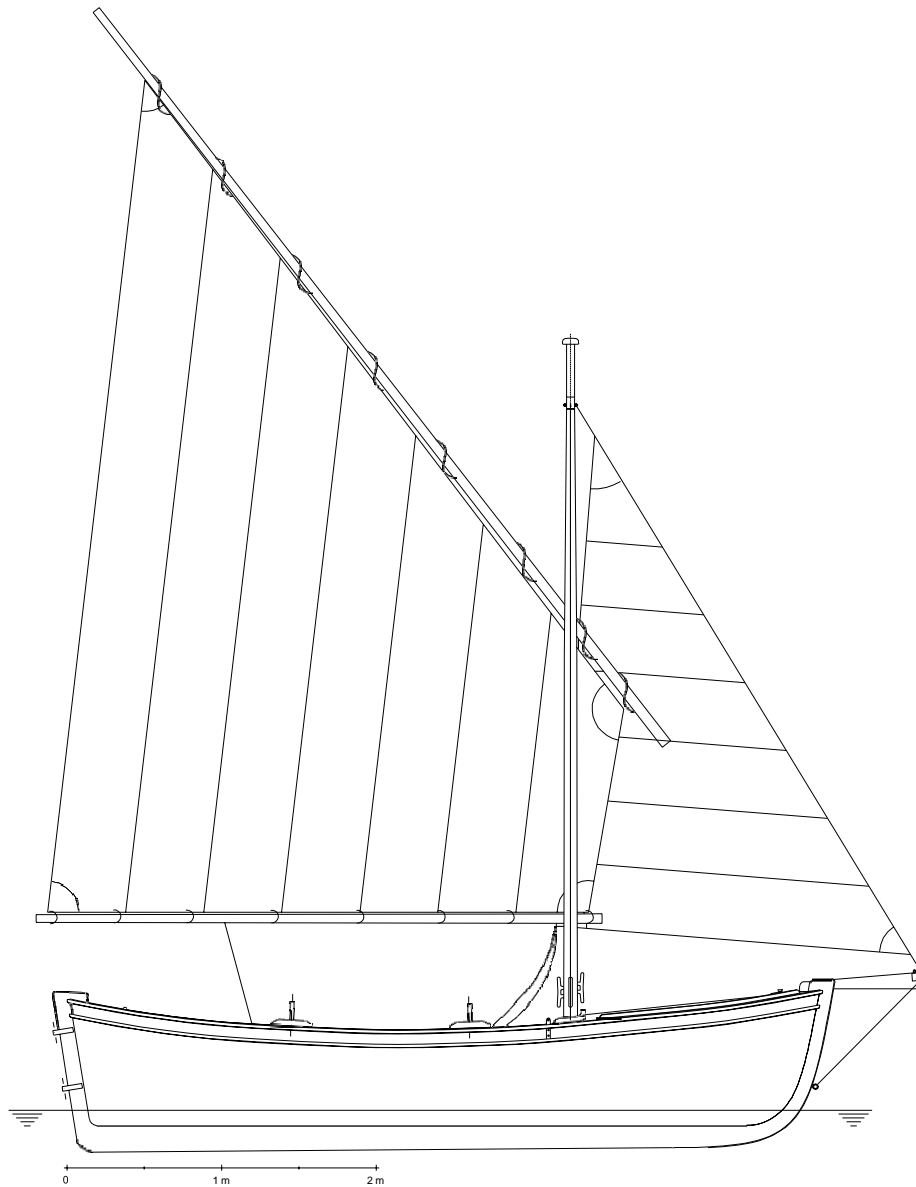

Insert a photo with a general view of the boat in the frame below



**Name of the compiler**

Prof. Robert Mohović, PhD  
Igor Knapić, B.Sc.

**Date of compilation**

20. 09. 2021.

## LP - PRIMORJE-GORSKI KOTAR COUNTY

### **Gajeta *Lastavica* (KK39)**



## Gajeta KK 39

### Section 1: boat data

	<p><b>Motivation for the selection of the boat</b></p> <p>(the grid has the function of identifying and exposing the reason that motivated the selection of this specific boat for restoration and documentation)</p>
<b>Ethnographic / cultural significance</b>	<p><i>E.g. does the boat represent traditional boat types (e.g. bragozzo, batana, etc.) or traditional fishing techniques, crafts, traditions?)</i></p> <p>This gajeta is a valuable example of a restored traditional boat that will be used for demonstration sailing, and with which Krk enthusiasts will present themselves at festivals and regattas of traditional boats throughout Kvarner. Currently, the boat is in use (navigable) and moored in the port of Krk. Along with the city boats Bodulka and Bodul, Lastavica is the only boat from Krk that participates in regattas of traditional boats throughout Kvarner.</p>
<b>Historical significance</b>	<p><i>Is the boat related to any historical event? (include sports scores of particular relevance, personalities, etc.)</i></p> <p>Gajeta Lastavica KK 39 was built in 1958 by the shipbuilder Anton Pičuljan in Barbat on Rab for the client Anton Badurina from Jakišnica (registration number 158 SE). It is owned by Marko Mrakovčić from Krk. Gajeta came to the Mrakovčić family in 1980 when Marko's father Ivan Mrakovčić bought it. Gajeta is used for fishing and leisure.</p>
<b>Technical / nautical significance</b>	<p><i>Do the boat has particular design solutions, or represents nautical types of boats (e.g. Olympic classes, series, etc...), or the work of some famous designer?</i></p> <p>Gajeta has a full side shape, a relatively flat bottom and an abrupt transition of the bottom planking into hull planking. The underwater part of the gajeta has a fine shape similar to guc, while the deck is spacious and ends in a semi-circle, especially at the stern. The bow is decked to the mast, the deck then continues on the sides (side walks) to the small deck at the stern. As opposed to classical gajetas, this gajeta has a cabin and a low deck rail and a bulwark which is typical of leut. The gajeta has one mast, a lugsail and a jib, and an inboard engine. The boat structural elements are made of oak, while the planking is made of spruce.</p>



<b>Replica</b>	<p><i>Is the boat an exact reproduction of a boat matching one of the above criteria?</i></p> <p>The boat KK 39 is not a replica, but an original boat from 1958.</p>
----------------	---

<b>Identification data</b>	
<b>Current boat name</b>	Lastavica
<b>Current register number (if registered)</b>	KK 39
<b>Current harbour / location</b>	Port of Krk
<b>Current owner</b>	
<b>Contact person / site</b>	<p><i>Indicate name and contact data (e.g. tel., email, others) in order to have if needed further infos about the boat</i></p>

<b>Material data</b>	
<b>Boat type / Traditional type</b>	<p><i>Name of the traditional typology (e.g. bragozzo, batana, also giving further specification related to place) or boat's type (e.g. cutter, dinghy, etc.)</i></p> <p>Gajeta</p>
<b>Original function</b>	<p><i>Fishing, cargo or passengers transportation, leisure, sport,...</i></p> <p>The boat was used for fishing and leisure.</p>
<b>Rig</b>	<p><i>E.g. "al terzo", lateen, auric, etc.</i></p> <p>The gajeta has one mast, a lugsail and a jib.</p>
<b>Length</b>	8,13 m (length overall)
<b>Breadth</b>	2,89 m (breadth moulded)
<b>Draught</b>	0,80 m (from below the keel to the waterline of the hull)
<b>Tonnage or weight (if known)</b>	-

<b>Main materials and construction features</b>	<p><i>Indicate main construction features, e.g. hull materials and type of building (e.g. traditional wood building, oak wood, metal hull, etc.)</i></p> <p>The boat structural elements (keel, stem, sternpost, apron and inner post, floors and frames, bilge strakes, external sheer strakes, deck stringers, planksheer, top timbers, sheer strakes at the bulwark, caprail, deck beams) are made of oak. The hull planks of the underwater part of the boat are made of oak, while the planks above water line are made of ash. The deck planks are made of ash.</p>
<b>Historical data</b>	
<b>Date / period of construction</b>	<p><i>E.g. 1935 / the 50s, etc</i></p> <p>1958</p>
<b>Construction place / shipyard or builder</b>	<p><i>Indicate the place or if unknown the area, and the name of shipyard or shipbuilder</i></p> <p>The boat was built by Anton Pičuljan from Barbat/island of Rab.</p>
<b>Designer, if any</b>	<p>The shipbuilder Anton Pičuljan himself.</p>
<b>Historical presentation</b>	<p><i>Brief description of the life of the boat with reference to its original use and to events preceding the present restoration; indicate here also the previous names and register numbers, and previous owners, and restorations.</i></p> <p>The boat was used for small coastal fishing and later for leisure.</p> <p>The first owner was Anton Badurina from Jakišnica. The second owner was Ivan Mrakovčić from Krk, and the third, the current owner, his son Marko Mrakovčić.</p> <p>Apart from regular maintenance, there were no significant previous renovations.</p>
<b>Bibliography / links</b>	<p><i>Give a bibliography of published books or articles, or links to Internet resources (e.g. sites, social) on this specific boat (not about type or in general).</i></p> <p>-</p>

## **Section 2: technical description**

<b>Metric data and shape of the hull</b>	<p><i>Indicate the salient measurements (in addition to those of length and width) and describe the general shape of the hull (e.g. sheer, length / width proportion, etc.)</i></p> <p>The hull is 8.13 m long, 2.89 m wide (greatest) with a draught of 0.80 m and height of 1.31m (in the middle to the top of planksheer). The boat has 28 frames (frames F1 to F28). Midships (theoretical main frame) is between the frames F14 and F15 (distance between the floors is 8.5 cm).</p>
--	---

	<p>The ratio of length and width <math>L/B = 2.8</math>, the ratio of width and draught <math>B/T = 3.6</math>, the ratio of length and draught <math>L/T = 10.2</math>, the ratio of length and height <math>L/H = 6.2</math>, and the ratio of width and height <math>B/H = 6.2</math>, and the ratio of width and height <math>B/H = 2.2</math>.</p> <p>Gajeta has a full side shape, a relatively flat bottom and an abrupt transition of the bottom planking into hull planking. The underwater part of the gajeta has a fine form similar to guc, while the deck is spacious and ends in a semi-circle, especially at the stern.</p>
<p><b>Structural parts (keel and frames)</b></p>	<p><i>Description of the structure of the boat, also indicating the number and measures of the frames, and other structural parts.</i></p> <p>The boat structural elements (keel, stem, sternpost, apron, inner post, floors and frames, bilge stringers, external sheer strakes, deck stringers, planksheer, top timbers, sheer strakes at the bulwark, caprail, deck beams) are made of oak. The underwater hull planks are made of oak, and the planks above the waterline are made of ash. The deck planks are made of ash.</p> <p>The keel (oak) extends along the entire length of the boat and consists of three parts. It is 6.87 m long to the connection with the stem. At the stern the keel reaches the end of the boat, exceeding the screw stern tube post, to which it is attached, by 34 cm. The keel is 8 cm thick. Under the keel there is the false keel, which is made of one piece, 7.02 m long and 8 cm thick. At the bow, it turns into the stemson. The stern tube post, the sternpost and massive, the apron and the bow horizontal massive, and the floors are fastened to the keel with bolts 12 mm in diameter. The floors with frames are fastened to the keel with stainless steel bolts, 12 mm in diameter, and in some places the connections were additionally reinforced by stainless steel wood screws, also 12 mm in diameter.</p> <p>The stem and sternpost are made of oak. The stem is 2.05 m long to the stemson. It exceeds the deck by 73 cm at the fore part and 59 cm at the back. The stemson is 1.35 m long. The radius of curvature of the stem in the stemson is approximately 1.23 m. The stem is 13.3 cm wide on the outer side from the deck to the stemson (to the planks). The stem is 4.6 cm thick on the outer side under the deck, reducing to the stemson to 4.2 cm. The stem is protected on the outer side by a stainless steel band extending from the beginning of the false keel to 10 cm above deck. The sternpost is 93.5 cm long and vertical to the curved part of the post where the stern tube passes, while the lower part of the sternpost is 75 cm high and curved. The length of the sternpost from the upper fitting to the top is 46 cm, and 30 cm above deck. The width at the bottom of the vertical part</p>

of the sternpost along the upper part of the curved part of the sternpost is 13.5 cm, 16.5 cm under the upper fitting, 15.5 cm above the rubbing strake, 18 cm above the deck and 13 cm at the top.

The frames and floors are made of oak. The boat has 28 frames (F1 to F28). The boat is built according to the five-piece frame system (central floor, port and starboard floors, port and starboard frames). The top timbers were also installed with a low bulwark fastened to them. The side floors almost touch amidships, above the keel. The frames follow the line of the central floors. The distance between the frame line ranges from 19 to 21 cm. Midships (theoretical main frame) is between the frames F14 and F15 (distance between the floors is 8.5 cm). The floors are fastened to the keel with stainless steel bolts, 12 mm in diameter, passing through the entire height of the frame and keel. In certain places they are additionally fastened with stainless steel wood screws, also 12 mm in diameter. The floors are most frequently 6.5 to 7 cm thick and 8 to 9 cm wide (high) along the keel and 6.5 to 7 cm wide at the sides. The frames are also 6.5 to 7 cm thick and 6.5 to 7 cm wide in the lower part and 6 to 6.5 cm wide at the top. The side floors stretch mostly from the bilge stringers and slightly above them. The side floors and frames overlap in different lengths, but most frequently from 30 to 35 cm. The ends of frames and floors are profiled, i.e. skewed.

Bilge stringers are made of oak in two parts (port and starboard). The bilgestringers are fastened symmetrically on both sides of the frames at the connections to the floors. They are 12 cm wide at the fore part, 14 cm at the central part and 12.5 cm at the aft part (2 cm at the very end), and they are 2 cm thick.

The deck relies on the deck beams and halfbeams made of oak. The deck beams and the halfbeams are partially countersunk into the deck stringers. The deck beams and halfbeams are nailed to the deck stringers with galvanized nails, 80 x 6 mm. There are seven deck beams installed at the bow from the frame F27 (DB1) to between the frames F19 and F18 (DB7). There are 10 halfbeams, 7 cm (height) x 6.5 cm (thickness), installed to the port and starboard side of the deckhouse (cabin), respectively. Stern beam, which carries the stern deck planks, is installed along the frame F3, it is 8.5 cm high and 6 cm thick.

The bulwark consists of the deck top timbers, profiled massive wooden elements at the bow and stern parts of the boat, external and internal sheer strakes of the bulwark, lining at the fore part and the caprail. The bulwark is 17.5 cm high at the bow to the top of the caprail, 15 cm midships and 16.5 cm at the stern.

	<p>The caprail, made of oak, relies on the upper edges of the external and internal bulwark sheer strakes and top timbers. It is fastened to the external and internal bulwark sheer strakes with galvanized nails, 60 x 6 mm. The caprail stretches from the aft part of the profiled elements at the bow (frame F28) to the front bitts at the stern.</p>
<p><b>Planking (external / internal)</b></p>	<p><i>Description of the planking, with measures, and type of waterproofing (e.g. caulking, epoxy, other).</i></p> <p>The planking is made of 10 planks (planks A to J) from the keel to the sheer strakes. The planks are 2 to 2.5 cm thick. Some planks consist of several parts. The heads of the fore and aft part of the planks are vertical at mutual connections. The first two planks from the top are the bow end in sheer strakes, and the third planks end partially in the sheer strakes and partially in the stem. The other planks at the bow end in the stem, i.e. the stemson. The four top planks at the stern end in the sheer strake, while the fifth one partially ends at the sheer strake and partially in the sternpost. The other planks at the stern end in the sternpost, i.e. the stern tube post. Garboard strakes, made of oak, are built along the keel. The other planks of the underwater part of the boat are also made of oak, while the other planks are made of ash. The longitudinal spaces between the planks, as well as the heads at the connections, including the stem and sternpost are caulked by hemp wool.</p>
<p><b>Deck and openings</b></p>	<p><i>Description of the deck and the number and size of the different openings.</i></p> <p>The boat has a deck, a deck cabin, a hatch at the bow and two longitudinal thwart in the cockpit.</p> <p>The deck planks are fastened to the deck beams, specifically the central deck plank and 16 deck planks on port and starboard sides respectively at the widest part of the boat. The central deck plank, made of oak, consists of two parts. The stern part of the deck does not have a central deck plank, but the poop is made of 22 deck planks (11 to starboard and 11 to port from the buttocks). The deck is 23 cm wide between the cabin and the bulwark at the fore part and 21 cm at the aft part. Its width reduces along the cockpit coamings and is 9 cm at the end of the coamings. Other deck planks are made of ash, with nominal width of 6 to 6.5 cm and thickness of 2.5 cm. They end at the planksheers and follow the curvature of the planksheers or the ends are vertical and end along the deck hatch coamings, or they are nearly vertical and end along the edges of the deck cabin. Certain deck planks consist of several parts in length.</p>

	<p>The deck hatch is situated at the bow, 14 cm from the bow mooring bitt and moved to the port in relation to the boat centreline (the longitudinal hatch centreline is moved 18 cm to port). It is 66 cm away from the aft edge of the stem. The hatch is situated between the deck beams DB1 and DB2. External hatch dimensions are 46.5 cm (longitudinally) and 63 cm (transversally). The coamings are 14.5 cm high and 2 cm thick. The external dimensions of the hatch cover are 53 cm (longitudinally) and 70 cm (transversally), with a height of 7.5 cm.</p> <p>The total length of the deckhouse (cabin) and vertically profiled cockpit coamings along the sides is 4.08 m. The deck cabin is 1.79 m wide, 1.77 cm at the stern, and 1.52 m between the cockpit coamings. The height to the lower edge of the deck cabin roof is 43 cm at the aft part and 35 cm at the fore part. The deck cabin sides with profiled cockpit coamings and the front part of the deck cabin are made of 2 cm thick mahogany.</p> <p>There are longitudinal thwarts on the port and starboard sides in the cockpit, made in the same way. The thwart risers are made of oak of various rectangular cross-sections. A longitudinal oak board, stretching from the deck cabin bulkhead to the stern bulkhead, is installed to the horizontal thwart risers to the midsection of the boat on the upper side. The board is 9.5 cm wide and 2 cm thick. A board of the same length and thickness, 13 to 26 cm wide is installed at the sides as a fixed part of the thwart (this part of the thwart enters under the side deck to the deck stringer). A removable thwart, 25 cm wide and 2.5 m thick, is fitted between two horizontal planks on beams. The thwart on the port side is made in the same way, but it does not extend along the entire length to the deck cabin bulkhead (the fore part of the thwart is 48 cm away from it). This thwart relies on 4 beams as well.</p>
<p><b>Sails and rig</b></p>	<p><i>Describe in detail and provide the type (e.g. “al terzo”, lateen, auric, Marconi, etc.) and other features of the sails, and of the fixed and running rigging.</i></p> <p>Boat rigging consist of the mast, standing rigging, lug sail with a yard and a boom, and the running rigging.</p> <p>The boat has a spruce mast (glued) located approximately at 1/3 length from the bow (the distance from the fore part of the stem is 2.70 m). The mast is 7.21 m long. The mast diameter at characteristic cross-sections is the following: 12.5 cm to the foot, 12.3 cm at deck level, 11.7 cm at 1/4 length, 10.3 cm at half length, 8.8 cm at 3/4 length, 6.5 cm at hoop level, and 6.3 cm at the top. The mast foot is square in cross-section, 4.7 x 4.5 cm. When the mast is in its place, it is keyed on</p>

	<p>to the mast base. There are four double cleats installed at the mast, specifically to at the side, one in front and one aft of the mast. A hoop with eyes for attaching rigging elements is situated 55 cm from the truck and consists of two mutually connected parts. The two parts of the hoop, on the port and starboard side, are mutually connected by stainless steel screws, 10 mm in diameter. It is made of a brass band, 6 cm wide and 4 mm thick. It has 6 eyes, 5 cm wide, 3 cm high at outer edges with 8-mm bores, for attaching rigging. At the top of the mast (fore and aft part), about 10 cm above the hoop, there are navigation lights installed (white, mast and stern).</p> <p>The yard is 7.33 m long, hanging on the tackle on the mast hoop at approximately 1/3 length from the lower end. The yard is made of spruce (glued from three parts). The yard diameter at characteristic cross-section is the following: 6.5 cm at the bottom of the yard, 8.5 cm at 1/3 length, 8.2 cm at half length, 5.8 cm at 3/4 length and 4.5 cm at the top.</p> <p>The boom is 5.60 m long, made of spruce. The boom diameter at characteristic cross-sections is the following: 6.5 cm at the fore end of the boom, 7 cm at 1/4 length, 7.2 cm at 1/3 length, 7.1 cm at half length, 5.7 cm at 3/4 length and 4.4 cm at the after end. There is a guard (thin rope spun on it) 44.5 cm long at 26 cm from the fore part of the boom, to prevent the mast and the boom from damage during sailing.</p> <p>Standing rigging consists of two shrouds on each side and a forestay. The shrouds are made of braided synthetic black rope, 12 mm in diameter. The forestay is made off stainless steel rope, 5 mm in diameter. Running rigging consists of the yard halyard tackle, which has two wooden blocks and a braided polyester rope, a tension rope, main sail sheet made of a tackle consisting of the upper double block, a lower double block with an eye and a tension rope (sheet), then of the jibsheet and jib halyard.</p>
<p><b>Rudder and other steering elements</b></p>	<p><i>Describe the type and material of the rudder (e.g. tiller, wheel) and the other steering parts.</i></p> <p>The rudder is made of oak. The rudder blade is 59 cm wide at the widest part and 4.5/4.8 cm thick. The rudder blade is made of two planks fastened at the lower end, almost in its entire length, with a lath 4 cm wide and 4.5 cm thick. The running surface is 0.82 m high and the total height to the top of the rudder is 1.82 m. The approximate surface of the running part of the rudder blade is 0.5 m<sup>2</sup>. The rudder blade reaches a bit under the keel. The fore part of the rudder</p>

	<p>blade stretches to the top of the rudder. There are reinforcements (wooden laths and brass bands) fitted the top of the rudder blade running surface on both sides. These reinforcements stretch throughout the entire width of the rudder blade. Two brass fittings were fitted on the rudder at a mutual distance of 1.04 m. The upper fitting (male) is fastened to the rudder stock, 57 cm from the top. The lower fitting (female) is fastened at the bottom of the rudder, 1.66 m from the top, by a brass band. The tiller is made of oak and is 1.44 m long. It is profiled in the horizontal and vertical plane.</p>
<p><b>Other significant elements</b></p>	<p><i>E.g. inboard or outboard engine, changes made to the original hull, presence of incongruous elements, elements inserted for technical or regulatory reasons, etc.</i></p> <p>The boat was restored in her original form, except that during restoration modern tools were used and materials different from those used at the time the gajeta was built were coated with suitable coatings (e.g. stainless steel).</p> <p>The boat is driven by an engine, except when sailing.</p>
<p><b>Previous restorations</b></p>	<p><i>Indication and description of the previous restorations, if any, with indication of year, place/shipyard, replaced parts and work, if known.</i></p> <p>It is not known when the previous restorations were done, there was no reconstruction other than regular maintenance. The boat remained true to the original.</p>



## Annexes to the technical description

Add a plan of the boat, or sketch, not important if made by CAD or laser scanner or by free hand, but mandatory with 3 views (side, front, top), and in addition 1 side view with sail/s and rig, views of details if important; all the views with the reference measures

Plan

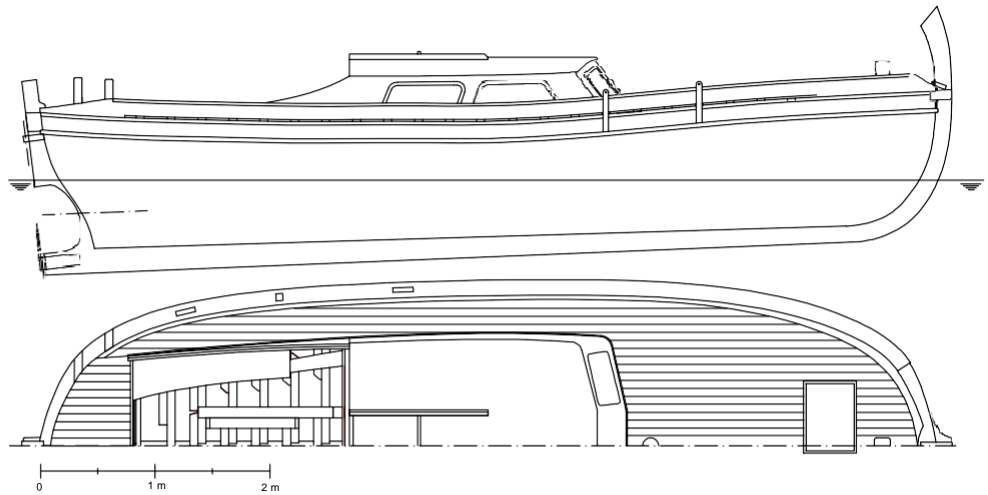

General arrangement

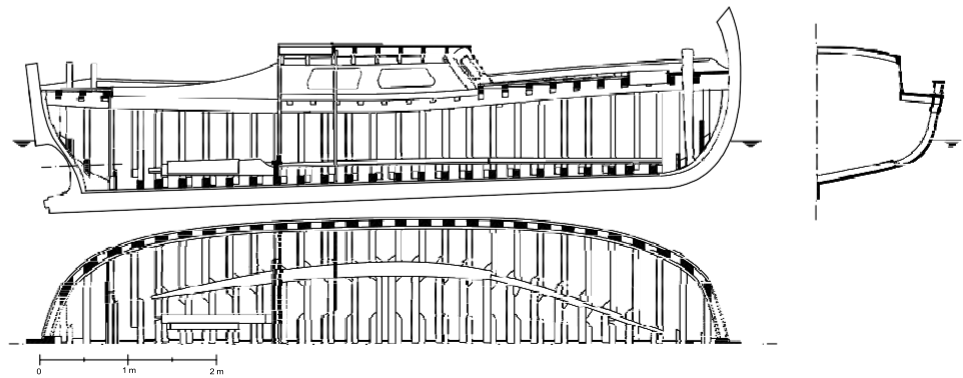

Construction drawings

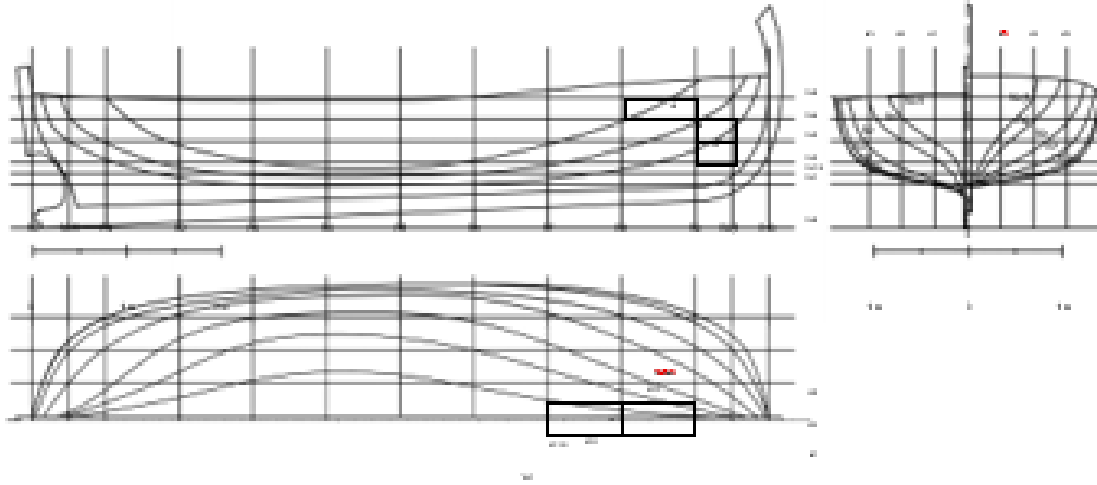

Boat lines

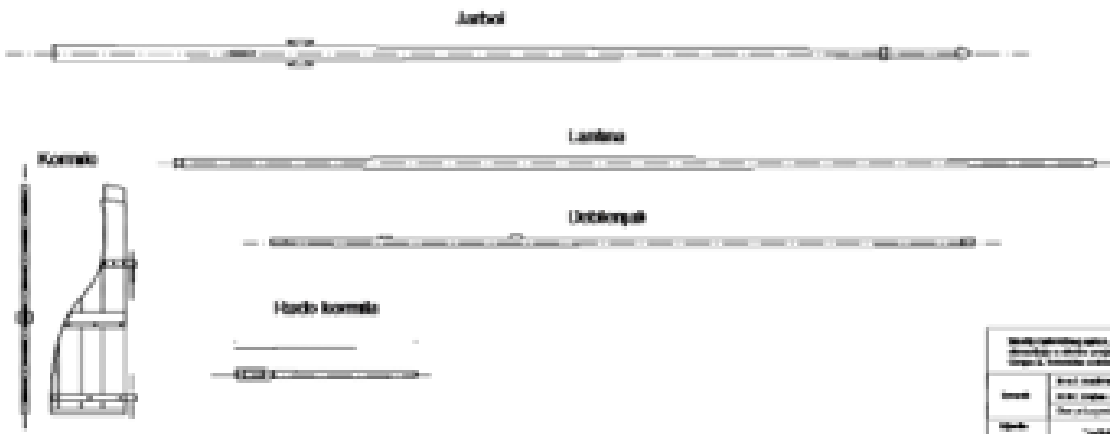

Rudder, tiller, mast, yard, boom

Insert a reduced plan of the boat in the frame below

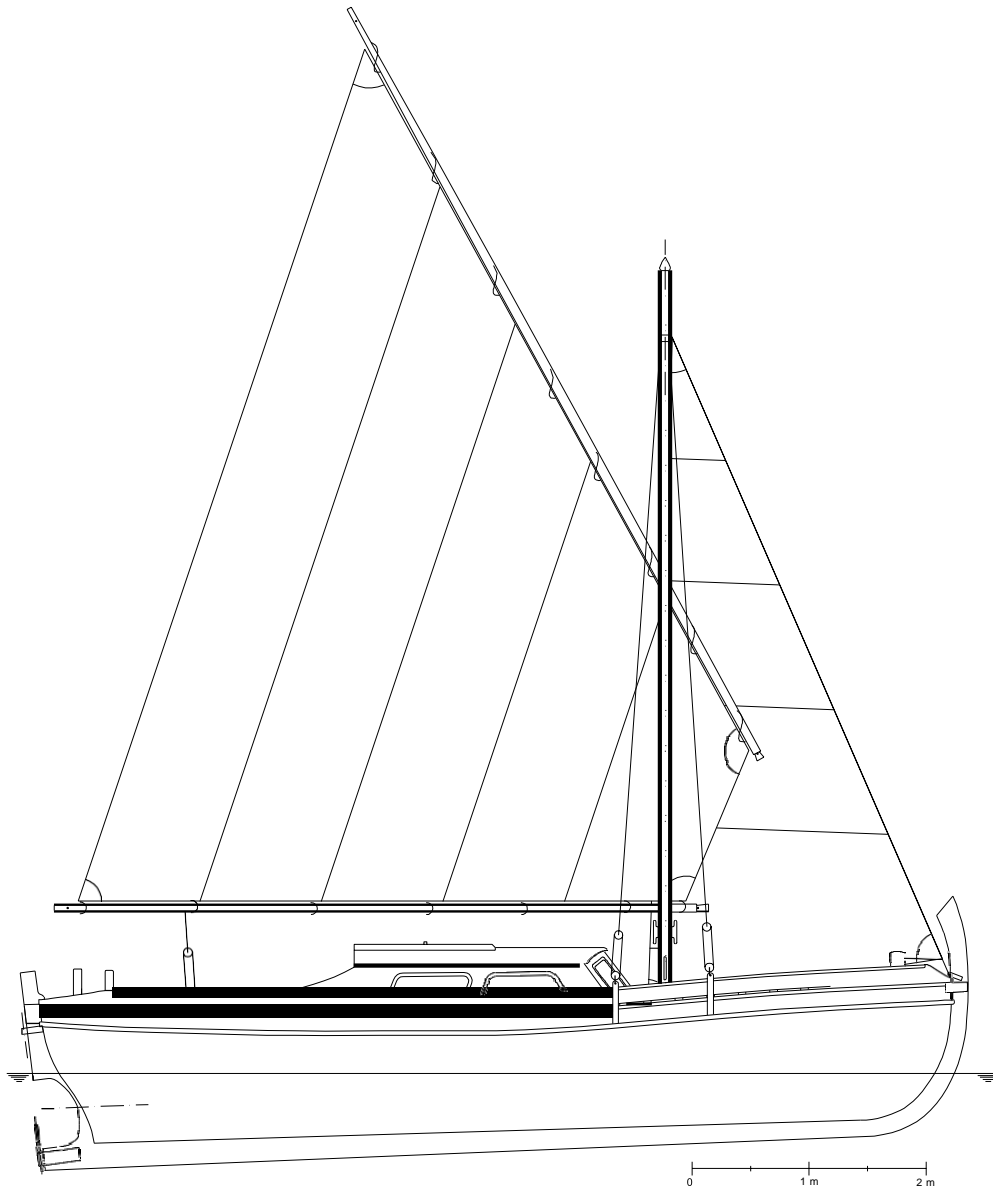

Insert a photo with a general view of the boat in the frame below



**Name of the compiler**

Prof. Robert Mohović, PhD  
Igor Knapić, B.Sc.

**Date of compilation**

20. 09. 2021.

## LP - PRIMORJE-GORSKI KOTAR COUNTY

### *Pasara Od ničesa (OP115706)*



## Pasara OP 115706

### Section 1: boat data

	<p><b>Motivation for the selection of the boat</b></p> <p><i>(the grid has the function of identifying and exposing the reason that motivated the selection of this specific boat for restoration and documentation)</i></p>
<b>Ethnographic / cultural significance</b>	<p><i>E.g. does the boat represent traditional boat types (e.g. bragozzo, batana, etc.) or traditional fishing techniques, crafts, traditions?)</i></p> <p>The boat is an example of a larger traditional pasara that was used for recreation and fishing purposes. This pasara is an example of a restored traditional boat that will be used for demonstration sailing and that will represent the owner an applicant the Association "Ikarski barkajoli" in festivals and regattas of traditional boats throughout Kvarner.</p>
<b>Historical significance</b>	<p><i>Is the boat related to any historical event? (include sports scores of particular relevance, personalities, etc.)</i></p> <p>Pasara with registration number OP 115706 was built in 1976 (place of construction and shipbuilder are not known, and the previous registration was KI 590). The boat was used mainly for recreational purposes.</p>
<b>Technical / nautical significance</b>	<p><i>Do the boat has particular design solutions, or represents nautical types of boats (e.g. Olympic classes, series, etc...), or the work of some famous designer?</i></p> <p>The pasara, just like other pasara boats, is characterised by the flat transom and the stem which may be more or less inclined forward. The pasara has a deck that is approximately 1/3 of her length and at the stern.</p>
<b>Replica</b>	<p><i>Is the boat an exact reproduction of a boat matching one of the above criteria?</i></p> <p>The boat OP 115706 is not a replica, but an original boat from 1976.</p>
	<b>Identification data</b>
<b>Current boat name</b>	Od ničesa

<b>Current register number (if registered)</b>	OP 115706
<b>Current harbour / location</b>	Port of Ika
<b>Current owner</b>	[REDACTED]
<b>Contact person / site</b>	<i>Indicate name and contact data (e.g. tel., email, others) in order to have if needed further infos about the boat</i> [REDACTED]

	<b>Material data</b>
<b>Boat type / Traditional type</b>	<i>Name of the traditional typology (e.g. bragozzo, batana, also giving further specification related to place) or boat's type (e.g. cutter, dinghy, etc.)</i> Pasara
<b>Original function</b>	<i>Fishing, cargo or passengers transportation, leisure, sport,...</i> The boat was used for recreational purposes.
<b>Rig</b>	<i>E.g. "al terzo", lateen, auric, etc.</i> The boat rigging consists of the mast and the bowsprit, the standing rigging, gaffsail with a gaff and the boom, and the running rigging.
<b>Length</b>	6,10 m (length overall)
<b>Breadth</b>	2,04 m (breadth moulded)
<b>Draught</b>	0,65 m (from below the keel to the waterline of the hull)
<b>Tonnage or weight (if known)</b>	-
<b>Main materials and construction features</b>	<i>Indicate main construction features, e.g. hull materials and type of building (e.g. traditional wood building, oak wood, metal hull, etc.)</i> Boat structural elements (keel, stem and apron, inner post, frames and floors and the stanchions, stringers, thwart risers and deck beams) are made of oak, and the transom, external and internal sheer strakes and caprail are made of mahogany.

	The hull planking is made of spruce, except the garboard strakes which are made of oak. The boat has a deck and thwarts. The deck planks are made of teak and the thwarts are made of mahogany.
--	---

	<b>Historical data</b>
<b>Date / period of construction</b>	<i>E.g. 1935 / the 50s, etc</i> 1976
<b>Construction place / shipyard or builder</b>	<i>Indicate the place or if unknown the area, and the name of shipyard or shipbuilder</i> The shipbuilder and the place of construction are unknown.
<b>Designer, if any</b>	-
<b>Historical presentation</b>	<i>Brief description of the life of the boat with reference to its original use and to events preceding the present restoration; indicate here also the previous names and register numbers, and previous owners, and restorations</i>  Pasara boat with registration number OP 115706 was made in 1976 (the place of construction and the shipbuilder are unknown, while the previous registration number was KR 590). The boat was used mostly for recreational purposes.  The previous owner was Robi Krulić, and since 2019 the owner is Emil Priskić.  Besides regular maintenance, there were no significant prior restorations.
<b>Bibliography / links</b>	<i>Give a bibliography of published books or articles, or links to Internet resources (e.g. sites, social) on this specific boat (not about type or in general)</i>  -

## **Section 2: technical description**

<b>Metric data and shape of the hull</b>	<i>Indicate the salient measurements (in addition to those of length and width) and describe the general shape of the hull (e.g. sheer, length / width proportion, etc.)</i>  The hull length is 6.10 m, 7.58 m with the bowsprit, the width (greatest) is 2.04 m, the draught is 0.65 m and the height is 0.97 m. The boat has 22 frames (frames F1 to F22). The theoretical main frame is between the frames F11 and F12.
--	---



	<p>The ratio of length and width <math>L/B = 3</math>, the ratio of width and draught <math>B/T = 3.1</math>, the ratio of length and draught <math>L/T = 9.4</math>, the ratio of length and height <math>L/H = 6.3</math>, and the ratio of width and height <math>B/H = 2.1</math>.</p> <p>The pasara is distinguished by the full hull shape and a wide stem because it is made for engine propulsion. The bow deck is spacious because the bow shape abruptly widens at the top of the frames, i.e. the planking.</p>
<p><b>Structural parts (keel and frames)</b></p>	<p><i>Description of the structure of the boat, also indicating the number and measures of the frames, and other structural parts</i></p> <p>Boat structural elements (keel, stem and apron, inner post, frames and floors and the top timbers, bilge stringers, thwart risers and deck beams) are made of oak, and the transom, external and internal sheer strakes and caprail are made of mahogany. The hull planking is made of spruce, except the garboard strakes which are made of oak. The boat has a deck and thwarts. The deck planks are made of teak and the thwarts are made of mahogany.</p> <p>The keel (oak) extends along the entire length of the boat and is 5.07 m long to the connection with the stem (the connection with the stem is 28 cm long). The keel reaches the end of the boat at the stern, exceeding the propeller shaft stern tube post to which it is attached by 18.5 cm. The height of the keel (outside the planking) is almost the same along the entire length of the boat and together with the false keel, it is 20 to 20.5 cm; at the very end, at the stern, it is 9.5 cm high. The keel is 5 cm thick. The propeller shaft stern tube post, the inner post and massive, the apron and the bow horizontal massive and the frames are fastened to the keel.</p> <p>The stem, made of oak, is 1.56 m long (flat vertical part is 90 cm long). The radius of curvature of the stem in the stemson is approximately 68 cm. The width (height) of the stem is 5.7 cm to the connection with the keel and false keel. At the bow, the lower part of the keel is connected to the stem by an insert 80 cm long and 7 cm wide (at the widest part). This insert provides a continuous transition of the lower part of the keel into the stem. It is 5 cm thick in the stemson, 2.5 cm at the water line and then widens at the top (at the very top of the stem it is 13.5 cm thick). It does not surpass the caprail (the caprail relies on the top of the stem). The stern ends in a transom made of oak. The width at the top is 1.5 m, the height is 64 cm and it is 5 cm thick. The transom is curved at the sides and defines the hull shape at the stern (looking from the outside in the upper part convex with approximate radius of 18 cm, and in the lower part</p>

concave with approximate radius of 28 cm). The so called “zero” frame is fastened with stainless steel bolts, 8 mm in diameter, to the transom.

The frames and floors are made of oak. The boat has 22 frames (frames F1 to F22). From the frames F4 to F9, the boat is constructed according to the 5-piece system (central floor, two side floors which are mutually connected at the buttocks, and the port and starboard side frames), while between the frames F10 to F18 she is built according to the 3-piece system (floor and port and starboard side frames). After this restoration, the top timbers were added to all frames, except the old ones. New frames are the frames F1 S/P, F2 S/P, F3 P, F10 S/P, F15 S and F22 P. The distance between the frame lines varies between 25 and 30 cm (most often between 26 and 27 cm). Midships (theoretical main frame) is between the frames F11 and F12. The floors are made (except the frames F1, F2, F3, F19, F20, F21 and F22) as classic floors consisting of one piece, 3 to 3.6 cm thick (most often 3.3 to 3.5 cm). The floors are wider (higher) in the middle and narrow down at the ends.

The bilge stringers, made of oak, consist of two parts and extend from the frames F1 to F19; they are 10.5 cm wide at the bow, 11.5 to 13 cm at the central part and 13.5 cm at the stern. They are 2 cm thick. They are fastened symmetrically on both sides of the frames, at the joints with the floors in the central part. Besides providing longitudinal strength, the stringers serve as side boundaries for the limber boards.

The caprail, made of mahogany, relies on the upper edges of external and internal sheer strakes. It is fastened to the external and internal sheer strakes with stainless steel wood screws, 40 x 4 mm (at the distance of 17 to 34 cm). The caprail is 15.5 cm wide at the bow, then narrows down to 14.5 cm, it is 14 cm wide in the central part and 14.5 cm at the stern, with thickness of 2 cm. The port and starboard side caprail is made of two pieces.

The boat has 7 deck beams at the bow (DB1 to DB7) and two beams at the stern which carry the deck. Deck beams are made of oak. The bow deck beams fit into the slots made in the internal sheer strakes and extend from side to side. The beams are curved so as to make a deck camber (PS7 has a camber of 9 cm, then the camber reduces towards the bow). All bow deck beams have a cross-section of 5 x 4.5 cm. Two stern deck beams, 4.5 x 4 cm in cross-section, also fit into the slots made in the internal sheer strakes and extend from side to side.

<p><b>Planking (external / internal)</b></p>	<p><i>Description of the planking, with measures, and type of waterproofing (e.g. caulking, epoxy, other</i></p> <p>The planking is made of 11 planks (planks from A to K) from the keel to the external sheer strake. The planks are 2.2 cm thick and they consist of several pieces. The planks end at the stem, while at the stern they end at the transom. Garboard strakes, made of oak, are installed along the keel, while the other planks are made of spruce. The planks are fastened to the floors, frames and top timbers with galvanized nails and stainless steel wood screws, dimensions 40 x4 mm. Nail or screw heads are countersunk into the plank, and the holes are filled with epoxy and ground. The longitudinal distance between the planks, including the heads on the connections, and the stem and transom are caulked with hemp wool.</p>
<p><b>Deck and openings</b></p>	<p><i>Description of the deck and the number and size of the different openings</i></p> <p>The boat is decked up to 1/3 of her length and at the stern. The rest of the deck is open. The boat has two thwarts and one thwart side.</p> <p>The deck was made by placing and fastening an 8-mm thick waterproof plywood to the deck beams. The plywood was then protected with protective coatings and then teak deck planks were attached to it (glued and fastened with one stainless steel wood screw, 40 x 4 mm to each deck beam). Screw heads were countersunk into the planks and then covered with teak plugs, 10 mm in diameter. The bow deck consists of the central deck plank and 10 deck planks on port and starboard sides respectively. Deck planks are pressed against each other. Each bow and stern deck plank is made of one piece. The central deck plank is 13 cm wide, 1.8 cm thick and exceeds other planks by 0.5 cm. Other bow deck planks have a nominal width of 6 cm and thickness of 1.3 cm.</p> <p>The hatch was lined with lower longitudinal and transversal coamings made of mahogany. There is a wash-board (breakwater) at the fore part of the hatch, which stretches between the internal sheer strakes and follows the curvature of the deck beam DB7 to which it is attached. The coaming is 12.5 cm high and 1.8 cm thick. A mahogany plank was fitted on the front side of the hatch aft edge, which closes the space between the deck and the stern thwart. The plank is 1.43 m long, 19 cm wide at the ends and 22 cm in the middle, and 2 cm thick. Side coamings extend along the hatch from the bow deck beam DB7 to the fore stern deck beam. The coamings are 6 to 6.5 cm high, 1.8 cm thick and they exceed the caprail by 2.7 cm.</p>

	<p>The boat has two thwarts and a stern seat, i.e. a stern part of the thwart between two longitudinal thwarts. They are 3.08 m long and stretch from the frame F2 to the frame F14. Side thwarts are 39 cm wide (37 cm at the stern itself). Longitudinal thwarts consist of two mahogany planks 3.5 cm thick, and there is a 4-mm gap between the planks to assist in water discharge. The stern part of the thwart is 1.50 m wide at the aft part (76 cm between the aft parts of the longitudinal thwart) and 1.60 m wide at the fore part (86 cm between the longitudinal thwarts). The length of the stern part of the thwart is 57 cm (longitudinally). The transition from the stern part of the thwart to the longitudinal part is made by a concave curvature. The stern part of the thwart between the longitudinal thwarts consists of five 3.5 cm thick planks. The planks are 15 to 19 cm wide (the middle and the third plank form the middle to the port and starboard are made of oak and the other two are made of mahogany).</p>
<p><b>Sails and rig</b></p>	<p><i>Describe in detail and provide the type (e.g. “al terzo”, lateen, auric, Marconi, etc.) and other features of the sails, and of the fixed and running riggin</i></p> <p>The rigging consists of the mast and the bowsprit, standing rigging, gaffsail with the gaff and the boom and the running rigging.</p> <p>The boat has a mast located at approximately 1/3 of her length from the bow (at 2.09 m). The mast is 6.65 m long and is made of spruce (glued from three pieces). The mast diameter at characteristic cross-sections is the following: 9.6 cm at the bottom to the foot, 11.6 cm at deck level, 10.8 cm at 1/4 length from deck, 10.4 cm at half length, 8.5 cm at 3/4 length, 7.9 cm at hoop level, and 5.7 cm at the top. The mast foot is rectangular in cross-section, with dimensions 8 x 2 x 3 cm. There are two wooden double cleats fitted to the mast, towards the aft under an angle of 45° and 30 cm from the deck, and a double cleat on the fore part of the mast. A hoop with eyes for attaching the rigging elements is located at 5.95 m from the mast foot (54 cm from the top of the mast). It is made of stainless steel band, 6 cm wide and 6 mm thick. The outer diameter of the hoop is 90 mm and it has 5 eyes welded on it.</p> <p>The length of the gaff is 4.40 m. It is made of spruce (glued from three pieces). The lateen yard diameter at characteristic cross-sections is the following: 6 cm at the bottom of the yard, 5.8 cm at 1/4 length, 6.3 cm at 1/3 length, 6.3 cm at half length, 6.3 cm at 3/4 length and 5.4 cm at the top. The crutch is made of mahogany, 50 cm long and 2 cm thick, with maximum width of 23 cm and mutual inner distance of 11.5 cm and the crutch depth (longitudinally) of 18 cm (the crutch is rounded with the greatest width of 5 cm).</p>

	<p>The boom, made of spruce (glued in three pieces), is 4.28 m long. The boom diameter at characteristic cross-sections is the following: 6 cm at the fore part, 6 cm at 1/4 length, 6 cm at 1/3 length, 6 cm at half length, 6 cm at 3/4 length and 5.6 cm at the top. The crutch is made of mahogany, 50 cm long and 2 cm thick, with maximum width of 23 cm and mutual inner distance of 13 cm and the crutch depth (longitudinally) of 18 cm (the crutch is rounded with the greatest width of 5 cm).</p> <p>The boat has a 3.65-m long bowsprit. It is made of spruce (glued from two pieces). The bowsprit diameter at the characteristic cross-sections is the following: 7.6 cm at the tenon, 7.8 cm at the stem, 7.6 cm at 1/4 length from the stem, 7.1 cm at half length, 6.6 cm at 3/4 length and 6 cm at the head. The tenon is conical (25 cm long and 6 cm in diameter at the end).</p> <p>Standing rigging consists of two wire rope shrouds (stainless steel), 5 mm in diameter. The forestay is made as a combination of wire rope, made of stainless steel 5 mm in diameter, and tension rope (braided polyester, beige), 10 mm in diameter. The forestay is now made of beige braided polyester, 10 mm in diameter (a rope is tied to the lower eye on the bowsprit head, passes through the eye on the stem and returns through the eye at the bowsprit head, then tensions and ties to the bow bit). Running rigging consists of two gaff halyards (outer and inner), tack purchase sheet, mainsheet and jib sheet and jib halyard. All running rigging is made of beige braided polyester of different thickness.</p> <p>The boat is equipped with a gaff sail and a jib made of canvas (drabbet, 190 g/m<sup>2</sup>). The sails are traditionally made with the sails hemmed with rope (luff line), except at the leech, with vertical sail panels. The sails are light beige, without decorations. The main sail surface is 20.1 m<sup>2</sup>, with one reef, while the surface of the auxiliary sail (jib) is 7.2 m<sup>2</sup>.</p>
<p><b>Rudder and other steering elements</b></p>	<p><i>Describe the type and material of the rudder (e.g. tiller, wheel) and the other steering parts.</i></p> <p>The rudder is made of oak and the reinforcements on the rudder stock are made of mahogany. The rudder blade is 39 cm wide and 4 cm thick. The rudder blade is made of a single plank. The height of the running surface of the blade is 0.72 m, and the overall height to the top of the rudder is 1.60 m. The rudder blade surface is 0.28 m<sup>2</sup>. The rudder blade length under the keel is 24 cm. The rudder stock is reinforced on both sides with two reinforcements 69 cm long, 14.5 to 21 cm wide at the widest part and 1.4 cm thick. Two stainless steel metal fittings</p>

	<p>(male) were installed on the rudder and painted with brass-effect varnish. The fittings are placed at the mutual distance of 53 cm. The upper fitting is installed at 17 cm from the top of the rudder stock, while the bottom fitting at placed 74 cm from the top, i.e. 82 cm from the bottom of the rudder blade. The tiller is made of mahogany and is 1.39 m long. It is slightly profiled in the horizontal and vertical plane.</p>
<p><b>Other significant elements</b></p>	<p><i>E.g. inboard or outboard engine, changes made to the original hull, presence of incongruous elements, elements inserted for technical or regulatory reasons, etc.</i></p> <p>The boat was restored in her original form, except that during restoration modern tools were used and materials different from those used at the time the pasara boat was built were coated with suitable coatings (e.g. stainless steel).</p> <p>The boat is driven by an inboard engine, and oars and sails.</p>
<p><b>Previous restorations</b></p>	<p><i>Indication and description of the previous restorations, if any, with indication of year, place/shipyard, replaced parts and work, if known</i></p> <p>It is not known when the previous restorations were done, there was no reconstruction other than regular maintenance. The boat remained true to the original.</p>

## Annexes to the technical description

Add a plan of the boat, or sketch, not important if made by CAD or laser scanner or by free hand, but mandatory with 3 views (side, front, top), and in addition 1 side view with sail/s and rig, views of details if important; all the views with the reference measures

### Plan

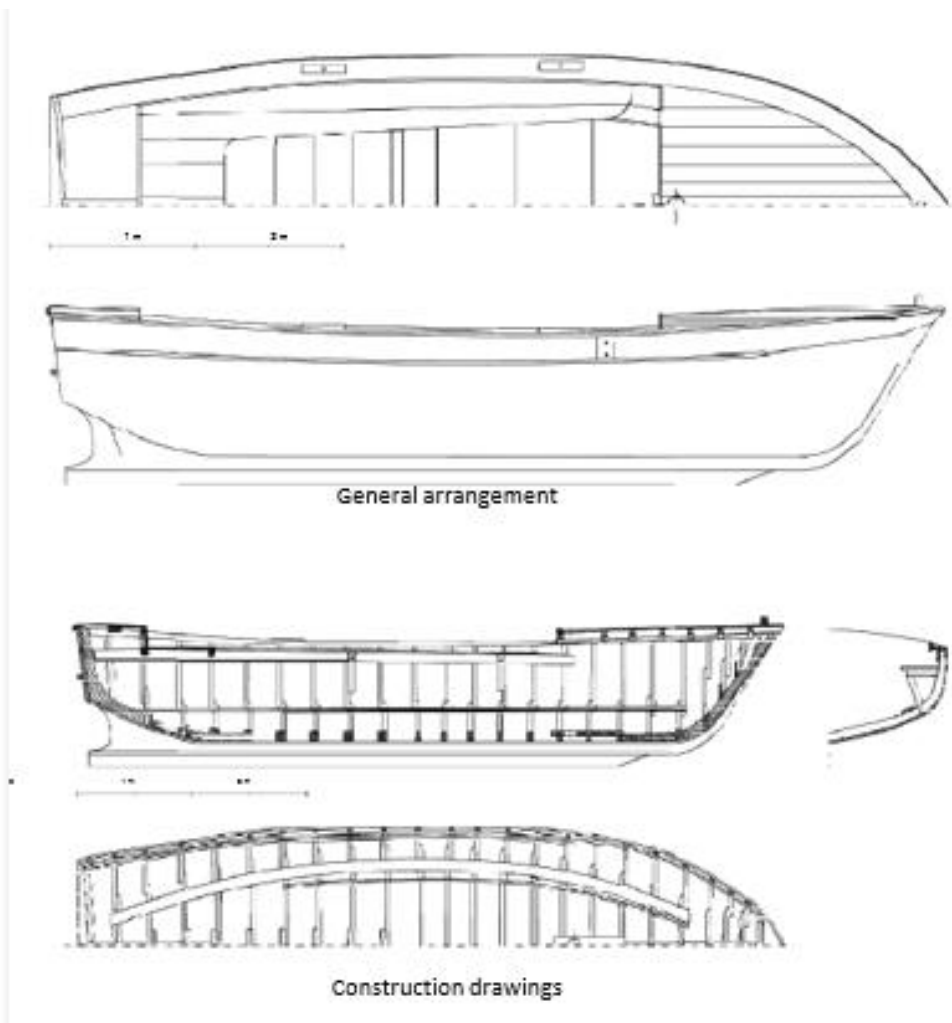

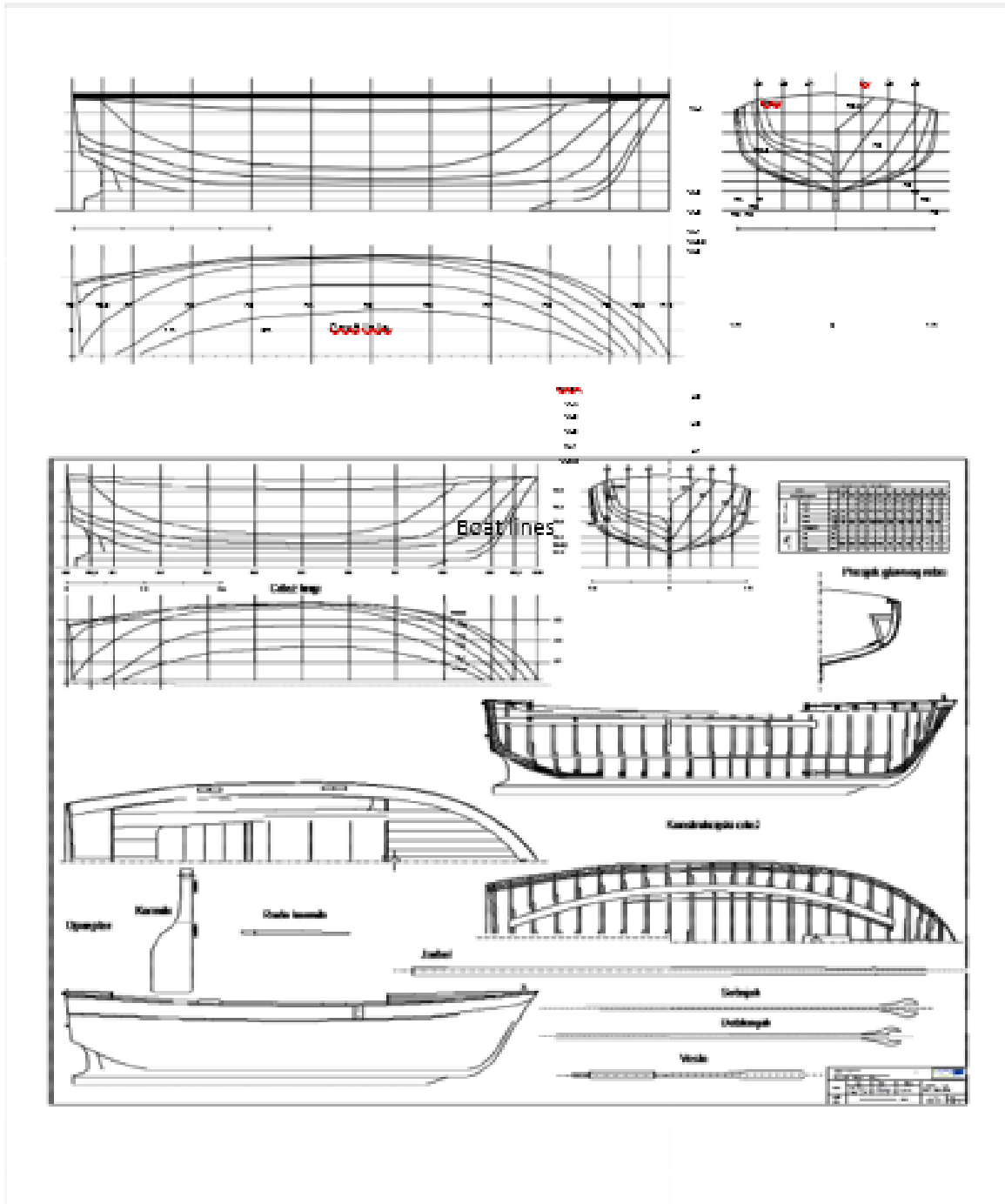

General arrangement, construction drawings, boat lines, rudder, tiller, oars, mast, bowsprit, yard, boom



Insert a reduced plan of the boat in the frame below

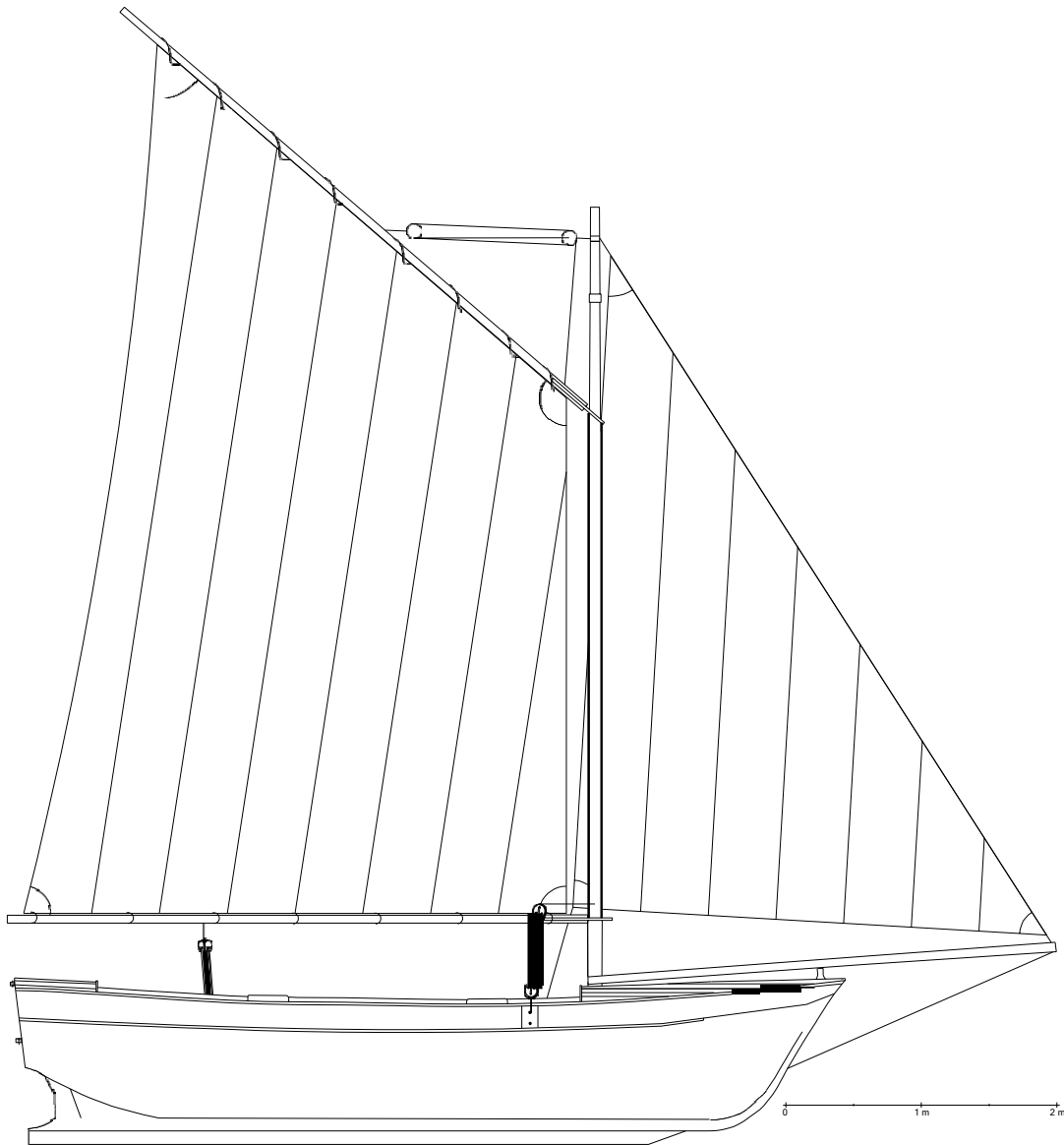

Insert a photo with a general view of the boat in the frame below



<b>Name of the compiler</b>	Prof. Robert Mohović, PhD Igor Knapić, B.Sc.
<b>Date of compilation</b>	20. 09. 2021.

## PP 1 - MUNICIPALITY OF MALINSKA-DUBASNICA

### Pasara MK34



## Pasara MK 34

### Section 1: boat data

	<p><b>Motivation for the selection of the boat</b></p> <p><i>(the grid has the function of identifying and exposing the reason that motivated the selection of this specific boat for restoration and documentation)</i></p>
<b>Ethnographic / cultural significance</b>	<p><i>E.g. does the boat represent traditional boat types (e.g. bragozzo, batana, etc.) or traditional fishing techniques, crafts, traditions?)</i></p> <p>The boat is a very valuable example of a smaller traditional pasara typical of the Malinska area, of which there are very few left in its original form.</p>
<b>Historical significance</b>	<p><i>Is the boat related to any historical event? (include sports scores of particular relevance, personalities, etc.)</i></p> <p>She was built by a local enthusiast for wooden boats, Ivo Kosić - Bučul from Vantačić in 1989, who is also the first owner of the boat. Prior to the renovation, she was used for personal purposes for leisure and small fishing, but also for setting up buoys in the bathing areas of the municipality of Malinska - Dubašnica. She has not been in navigable condition for the last three years. The boat is owned by Toni Kraljić from Malinska.</p>
<b>Technical / nautical significance</b>	<p><i>Do the boat has particular design solutions, or represents nautical types of boats (e.g. Olympic classes, series, etc...), or the work of some famous designer?</i></p> <p>The boat belongs to the group of small open deckless pasara boats, distinguished by specific features typical for this kind of boat, a flat transom and a slightly curved bow with the stem inclined forward. She has a design classical for this kind and size of vessel – with a thwart at the bow, two transverse thwarts and longitudinal thwarts at the stern ending in a transverse thwart at the stern itself. There is a removable “deck” between the bow and forward transverse thwart for handling nets.</p>
<b>Replica</b>	<p><i>Is the boat an exact reproduction of a boat matching one of the above criteria?</i></p> <p>The boat MK 34 is not a replica, but an original boat from 1989.</p>

	Identification data
Current boat name	-
Current register number (if registered)	MK 34
Current harbour / location	Port of Malinska
Current owner	[REDACTED]
Contact person / site	Indicate name and contact data (e.g. tel., email, others) in order to have if needed further infos about the boat [REDACTED]

	Material data
Boat type / Traditional type	Name of the traditional typology (e.g. bragozzo, batana, also giving further specification related to place) or boat's type (e.g. cutter, dinghy, etc) Pasara
Original function	Fishing, cargo or passengers transportation, leisure, sport,... Before restoration, the boat was used for leisure and small fishing, but also for placing buoys in the bathing areas of the municipality Malinska – Dubašnica.
Rig	E.g. "al terzo", lateen, auric, etc. The boat is equipped with traditional rigging (one mast, lugsail and jib).
Length	4,375 m (length overall)
Breadth	1,61 m (breadth moulded)
Draught	0,48 m (from below the keel to the waterline of the hull)
Tonnage or weight (if known)	-

<b>Main materials and construction features</b>	<p><i>Indicate main construction features, e.g. hull materials and type of building (e.g. traditional wood building, oak wood, metal hull, etc.)</i></p> <p>Boat structural elements (keel, stem, sternpost, apron, inner post, floors, frames, bilge strakes, caprail and thwarts) are made of oak from Krk and Slavonia forests, while the planking is made of spruce (carvel).</p>
	<b>Historical data</b>
<b>Date / period of construction</b>	<p><i>E.g. 1935 / the 50s, etc</i></p> <p>1989</p>
<b>Construction place / shipyard or builder</b>	<p><i>Indicate the place or if unknown the area, and the name of shipyard or shipbuilder</i></p> <p>Ivo Kosić – Bučul from Vantačića</p>
<b>Designer, if any</b>	<p>The shipbuilder Ivo Kosić – Bučul himself.</p>
<b>Historical presentation</b>	<p><i>Brief description of the life of the boat with reference to its original use and to events preceding the present restoration; indicate here also the previous names and register numbers, and previous owners, and restorations</i></p> <p>Prior to the renovation, the boat was used for personal purposes, primarily for leisure and small fishing, but also for setting up buoys in the bathing areas of the municipality of Malinska - Dubašnica. She has not been in navigable condition for the last three years.</p> <p>The previous and the first owner was Ivan Kosić from Vantačić near Malinska, who built the boat himself in 1989. The second and current owner is Toni Kraljić from Malinska.</p> <p>Apart from regular maintenance, there were no significant previous renovations.</p>
<b>Bibliography / links</b>	<p><i>Give a bibliography of published books or articles, or links to Internet resources (e.g. sites, social) on this specific boat (not about type or in general)</i></p> <p>-</p>

## Section 2: technical description

<p><b>Metric data and shape of the hull</b></p>	<p><i>Indicate the salient measurements (in addition to those of length and width) and describe the general shape of the hull (e.g. sheer, length / width proportion, etc.)</i></p> <p>The hull length is 4.375 m, 5.01 m with the bowsprit. The (greatest) width is 1.61 m, the draught is 0.48 m at the stern, and the height in the middle is 0.78 m. The boat has 16 frames (frames F1 to F16). Midships (theoretical main frame) is between the frames F8 and F9.</p> <p>The ratio of length and width <math>L/B = 2.7</math>, the ratio of width and draught <math>B/T = 3.4</math>, the ratio of length and draught <math>L/T = 9.1</math>, the ratio of length and height <math>L/H = 5.6</math>, and the ratio of width and height <math>B/H = 2.1</math>.</p> <p>The boat belongs to the group of small open deckless pasara boats, distinguished by specific features typical for this kind of boat, a flat transom and a slightly curved bow with the stem inclined forward.</p>
<p><b>Structural parts (keel and frames)</b></p>	<p><i>Description of the structure of the boat, also indicating the number and measures of the frames, and other structural parts.</i></p> <p>Boat structural elements (keel, floors and frames, stem, sternpost, transom, bilge strakes, thwart risers, sheer strakes (external and internal), caprail and transverse thwarts) are made of oak. The planks are made of spruce, just like the stern longitudinal thwarts.</p> <p>The keel, made of oak, stretches along the entire length of the boat and is approximately 3.34 m long. At the bow it connects with the stem, and at the stern it stretches to the end of the boat (the sternpost relies on it). The keel height is smaller at the bow, and larger at the stern, so the keel height outside the hull ranges from 12 cm at the bow, 15 cm amidships and 18.5 cm at the stern. The height of the garboard strakes, which is 2 cm, should be added to get the total height of the keel. The keel consists of two parts in height, with the lower being 4.5 cm high at the fore part, widening towards the stern to 6.5 cm. The keel is rectangular in cross-section, 4.5 cm wide. The floors, along with the bow and stern massive and apron are fastened to the keel by 10 mm bolts.</p> <p>The stem, made of oak, is 1.70 m long, 8 cm wide at the top (14.5 cm wide with the apron), while outside the planks it is 6.5 cm wide next to the rubbing strakes, 8.5 cm in the stemson and 9 cm to the scarf. The radius of curvature of the stem is approximately 62 cm. The stem is 2.5 cm thick at the outer edge, widening</p>

	<p>towards the apron. The stem exceeds the caprail at the bow by 7 cm, with the fore and aft part of the stem is slightly curved and the top is flat. The sternpost, made of oak, is fastened at the transom and relies on the keel. It is 80 cm long, 8 cm wide at the top, 8 cm wide at the waterline and 6.5 cm wide at the bottom, and it is 3 cm thick at the top (it has a trapeze cross-section and widens to the transom to 3.5 cm), 3.5 cm thick at the waterline and 4 cm at the bottom.</p> <p>The boat has 16 frames (frames F1 to F16). The frames consist of 3 pieces (floor, port and starboard frames), with reinforcements built along some floors. Midships (theoretical main frame) is between the frames F8 and F9. Port and starboard bow frames are installed forward in relation to the frames (frames F10 to F16), while the port and starboard stern frames are installed towards the aft in relation to the frames (frames F1 to F9). Port and starboard frames are made of one piece, 6 to 6.5 cm wide and a nominal thickness of 2.5 cm. The frames narrow down from the bottom to the top (under the thwart risers they are 5 to 5.5 cm wide). The floors and frames are made of oak. The floors are made of one piece, 6.5 to 6.8 cm wide and 2.3 to 2.5 cm thick. The floors are wider (higher) in the middle and slightly narrow down towards the ends (6 to 6.5 cm).</p> <p>The bilge strakes are made of oak, 7.5 cm wide at the bow, 11 cm amidships and 6.5 cm at the stern. They are 2 cm thick. They stretch from the first to the fifteenth frame (F1 to F15). Each bilge strake is made of two pieces, with a vertical joint at the frame F7. Besides providing longitudinal strength, the stringers serve as side boundaries for the limber boards.</p> <p>The caprail, made of oak, relies on the upper edges of external and internal sheer strakes and is fastened by stainless steel wood screws, 50 x 5 mm. The caprail is 7.5 cm wide at the bow, 8.5 cm amidships and at the stern, with thickness of 2 cm. The port and starboard side caprail is made of two pieces with almost vertical joints between the frames F9 and F10. The ends (heads) of the caprail fore parts end right next to the stem, while at the fore part they are extended and rounded. The ends (heads) of the caprail stern parts reach the transom and the aft side of the transom, 4 cm wide (a part of the caprail is built into the transom).</p>
<p><b>Planking (external / internal)</b></p>	<p><i>Description of the planking, with measures, and type of waterproofing (e.g. caulking, epoxy, other).</i></p> <p>The planking is made of 9 planks (planks from A to I), symmetrically on both sides, from the keel to the external sheer strake. The planks are 2.2 cm thick, made of</p>



	<p>spruce, including the garboard strakes. The planks are fastened to the floors and frames by galvanized nails, 50 x 4 mm, and partially stainless steel wood screws, dimensions 40 x 5 mm. The heads of plank fore parts are skewed at the bow in longitudinal and transverse cross-section, so they end up right next to the stem. The heads of stern planks aft parts end at the transom, i.e. massive element at the joint between the keel and the transom. The heads of the fore and aft partsof planks are vertical at the mutual joints.</p>
<p><b>Deck and openings</b></p>	<p><i>Description of the deck and the number and size of the different openings</i></p> <p>Boat is open, deckless (with only thwarts). The boat has a thwart (forecastle deck) at the bow, transverse central thwart and a stern thwart consisting o two longitudinal thwarts and a stern thwart.</p> <p>The bow thwart is roughly triangular in shape, with sides following the curvature of the hull at the bow. It stretches to the frame F15. It is 44.5 cm wide (longitudinally), 73 cm long at the aft part, and ends in the bow with its top 6.5 cm wide. The bow thwart consists of two glued oak boards, 3 cm thick.</p> <p>The central thwart towards the bow is located at the frame F11 (1.61 m from the top of the stem), it is 133.5 cm long, 19 cm wide and 4.8 cm thick. In the middle of the thwart there is a hole for the mast, 7.5 cm in diameter (the centre is 1.71 m away from the top of the stem).</p> <p>At the stern, the aft part of the thwart has two supports (flat beams). The front support is attached between the frames F1 and F2, 4.5 x 3.5 cm in cross-section. The aft support is attached to the transom, 4.5 x 3.5 cm in cross-section. The aft part of the stern thwart is 46 cm long (longitudinally) and 88 cm wide at the stern along the transom. The side (longitudinal) parts of the stern thwart are 1.36 m long and 26 cm wide (forward), then 25 cm and 28 cm towards the stern. The distance between the longitudinal thwarts at the forward side is 76.5 cm, and towards the stern part of the thwart 50.5 cm. The central part of the stern thwart (between the longitudinal thwarts) consists of two boards, 48 cm wide (forward) and 34 cm wide along the transom.</p>
<p><b>Sails and rig</b></p>	<p><i>Describe in detail and provide the type (e.g. "al terzo", lateen, auric, Marconi, etc.) and other features of the sails, and of the fixed and running rigging</i></p> <p>The rigging consists of the mast, standing rigging, lugsail and jib, yard, boom and bowsprit and the running rigging.</p>

The boat has a 5.10-m long mast, located at 1.71 m from the fore edge of the stem. The lower mast is 4.51 m long to the hoop. The mast is made of cypress (glued from two pieces). The mast diameter at characteristic cross-sections is the following: 7.3 cm at the foot, 7.7 cm at the thwart level, 7.8 cm at 1/4 length from the thwart, 7 cm at half length, 6.8 cm at 3/4 length, 6.2 cm at hoop level, 4.2 cm at the top. The mast foot is square in cross-section, with dimensions 4.5 cm x

4.5 cm. At the top of the mast there is a truck, 8.6 cm in diameter and 8.2 cm high (cylindrical to half of its length, and then turns into a cone). There are three double cleats installed on the mast above the thwart, one on its fore part and two on the aft part (at approximately 45° in relation to the centreline).

The bowsprit, made of cypress, is 0.95 m long, conical in layout, 10 cm wide at the after end, then gradually narrows down in the following 60 cm in length; it is 6.5 cm wide in the middle, then turns into a round cross-section, having 5 cm in diameter at the end of the hoop and 4 cm at the very top. In the vertical plane, the bowsprit is 6 cm wide at the after part, then it slightly narrows down to 5.5 cm in the middle, and towards the top, as already mentioned, it turns to a round cross-section. At the top of the bowsprit (1.5 cm from the top), there is a hoop, 6 cm long and 4.8 cm in diameter. It is made of stainless steel sheet, 3 mm thick, with two rings 6 mm in diameter welded on it. The bowsprit is fastened to the stem with two stainless steel bolts, 8 mm in diameter.

The yard is 5.08 m long. It is made of spruce and glued from two pieces. The yard diameter at characteristic cross-sections is the following: 5.3 cm at the bottom, 6 cm at 1/4 length, 6.3 cm at 1/3 length, 6.5 cm at half length, 6.3 cm at 3/4 length and 5.5 cm at the top.

The boom, made of spruce, is 4.02 m long and glued from two pieces. The boom diameter at characteristic cross-sections is the following: 4.5 cm at the fore part, 5.7 cm at 1/4 length, 6 cm at half length, 6 cm at 3/4 length and 5.3 cm, and at the top.

The boat is equipped with a lugsail and an auxiliary sail, jib. Both sails are made of canvas (190 g/m<sup>2</sup>). The main sail surface is 12.6 m<sup>2</sup>, while the auxiliary sail surface is 3 m<sup>2</sup>. The sails are traditionally made with the sails hemmed with rope (luff line), except at the leech, with vertical sail panels. They are fastened to the yard and the boom with beige braided polyester roped, 6 mm in diameter. The main sail has one reef.

	<p>Standing rigging consists of two shrouds and a forestay. The shrouds are made of beige braided polyester, 10 mm in diameter. The forestay is made of beige braided polyester, 6 mm in diameter. The running rigging consists of a single block and yard halyard (12 mm in diameter), boom fore part sheet (10 mm in diameter), a single block and main sail sheet (12 mm in diameter), jib halyard (10 mm in diameter) and jib sheet (10 mm in diameter). All running rigging blocks are made of wood and brass, and the ropes are made of beige braided polyester.</p>
<p><b>Rudder and other steering elements</b></p>	<p><i>Describe the type and material of the rudder (e.g. tiller, wheel) and the other steering parts.</i></p> <p>The rudder is made of oak. The rudder blade is 45 cm wide at its widest part, 42 cm at the bottom (flat part), 17 cm at the waterline, 13 cm at the top before the part where the tiller is placed. The rudder blade consists of several planks, 3.6 cm thick. The approximate running surface of the rudder blade is 0.30 m<sup>2</sup>. The length of the rudder blade under the keel is 0.33 m. The top of the rudder stock is 8 cm high, 10 cm wide and 1.8 cm thick with rounded edges. It is made so the tiller is wedged on it. There are two stainless steel fittings installed on the rudder at a distance of 84 cm. The upper fitting (male) is installed at 7.5 cm from the top of the rudder stock (without the part to which the tiller is wedged), and the lower fitting (female) is installed at 94 cm from the top of the rudder stock, i.e. 40 cm from the bottom of the rudder. The tiller is made of yew wood and is 90 cm long. The tiller is 7 cm wide at the after end and for the first 20 cm (vertically), then narrows down sharply to 6 cm, then narrows gradually to 5 cm in the middle, turning into a round shape at the end, 3.5 cm in diameter. In the horizontal plane, it is 6.5 cm wide (thick) at the after end and for the first 20 cm, then narrows down to 4 cm which is its nominal thickness in the most part, then turning into a round cross-section, as was previously mentioned, 3.5 cm in diameter.</p>
<p><b>Other significant elements</b></p>	<p><i>E.g. inboard or outboard engine, changes made to the original hull, presence of incongruous elements, elements inserted for technical or regulatory reasons, etc.</i></p> <p>The boat was restored in her original form, except that during restoration modern tools were used and materials different from those used at the time the pasara was built were coated with suitable coatings (e.g. stainless steel).</p> <p>The boat is driven by oars and sails, or an outboard engine if necessary.</p>

<p><b>Previous restorations</b></p>	<p><i>Indication and description of the previous restorations, if any, with indication of year, place/shipyard, replaced parts and work, if known</i></p> <p>There were no previous renovations or reconstructions, except for regular maintenance. The boat remained true to the original.</p>
-------------------------------------	---

## Annexes to the technical description

### Plan

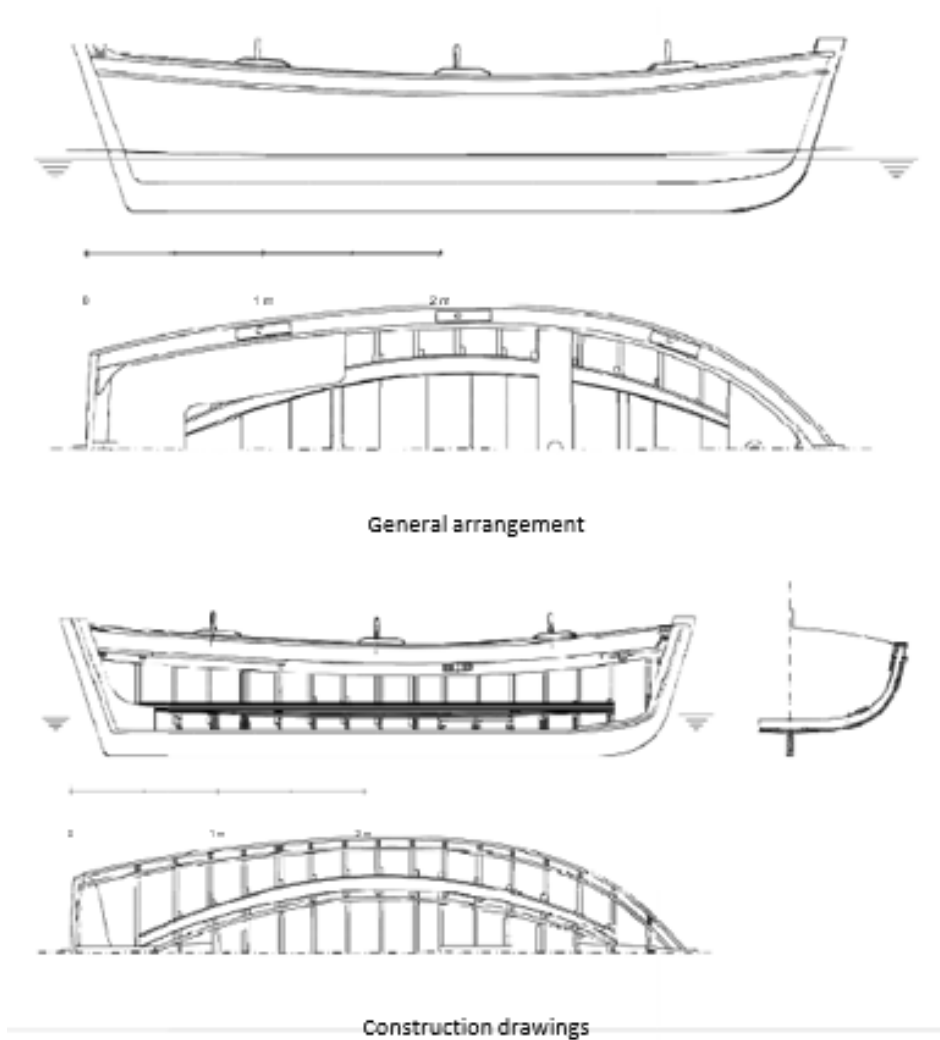

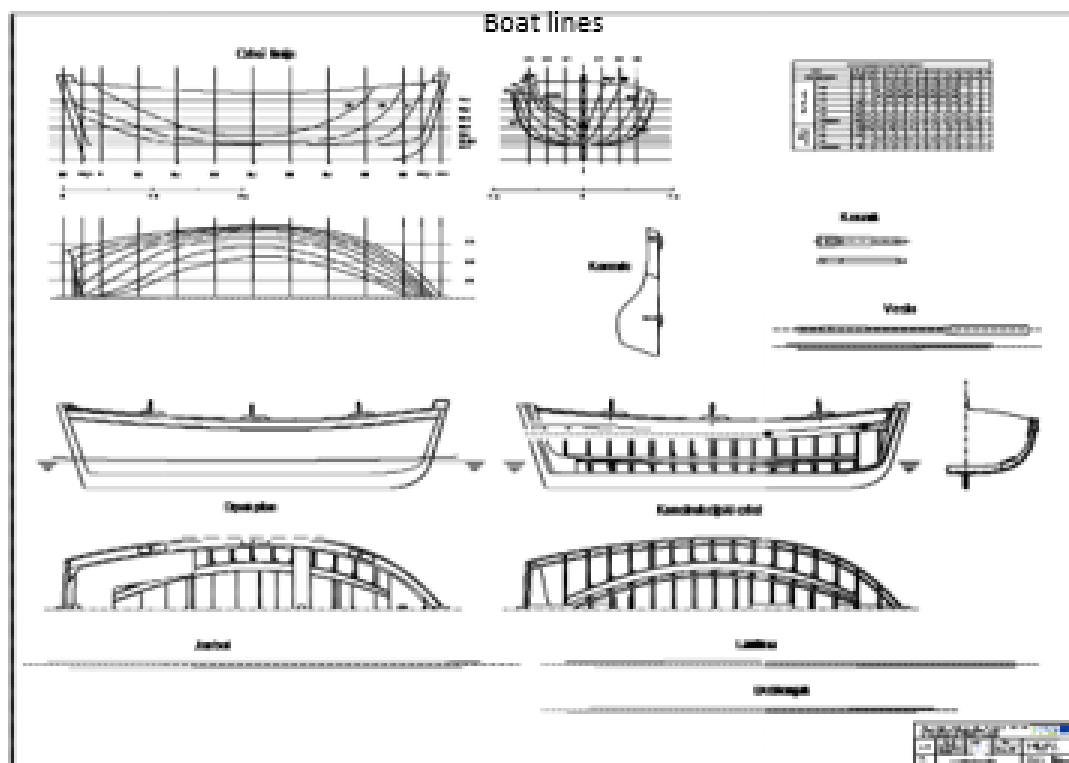
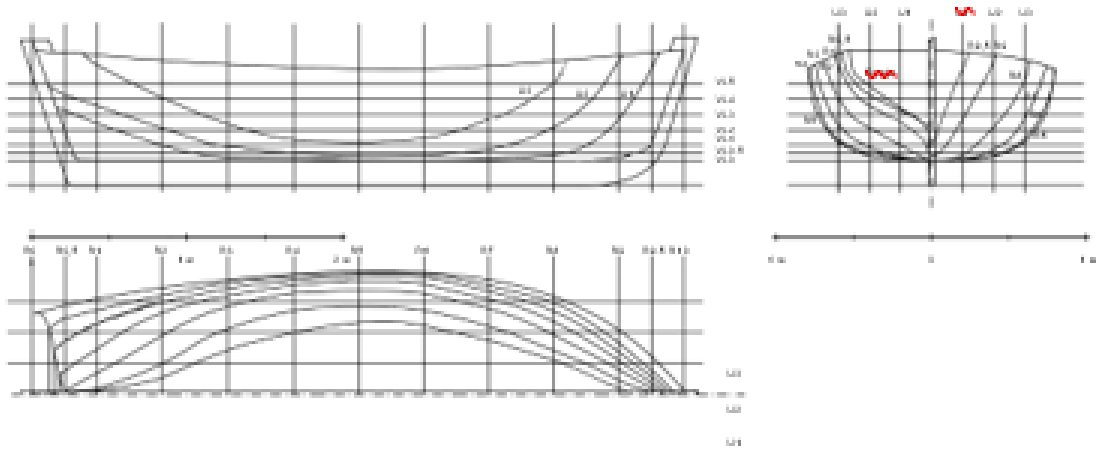

General arrangement, construction drawings, boat lines, rudder, tiller, oars, mast, bowsprit, yard, boom

Insert a reduced plan of the boat in the frame below

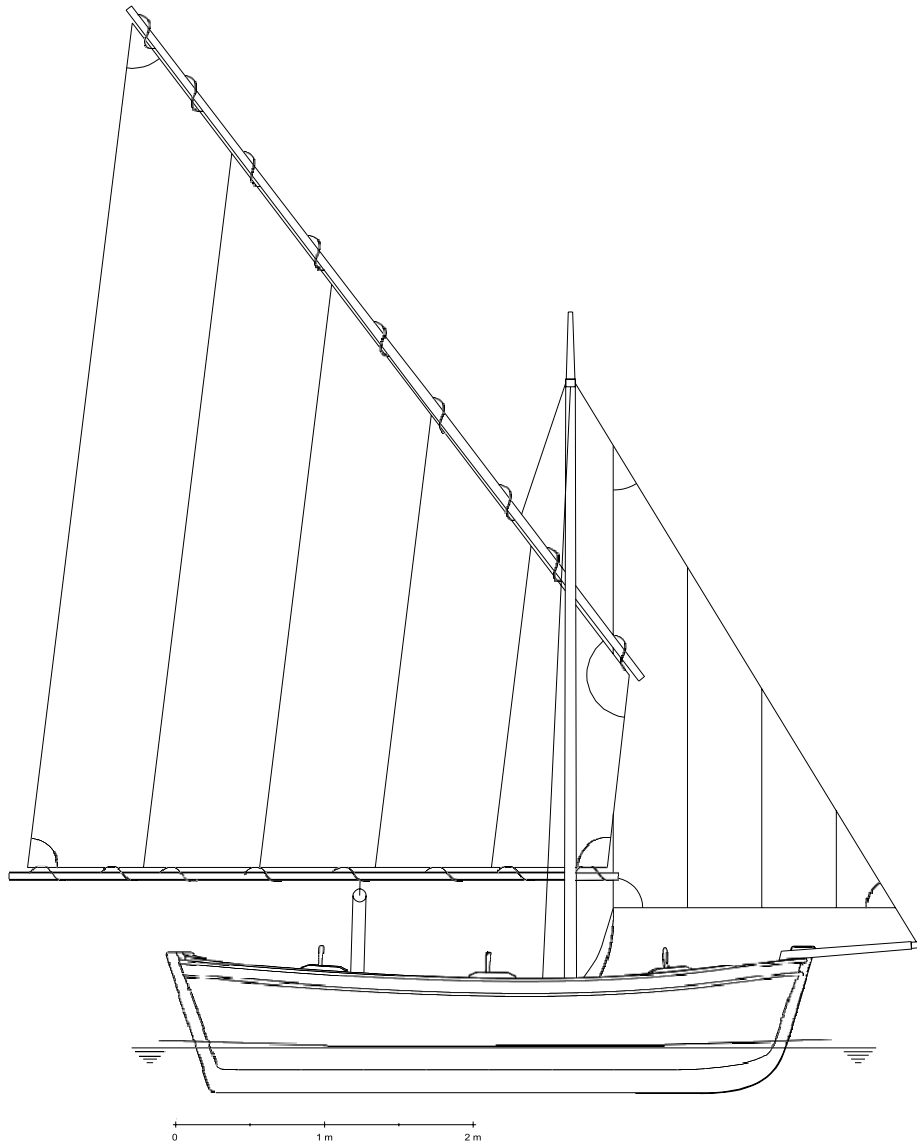

Insert a photo with a general view of the boat in the frame below



<b>Name of the compiler</b>	Prof. Robert Mohović, PhD Igor Knapić, M.Sc.nav.arch.
<b>Date of compilation</b>	15. 11.2021.



## PP 1 - MUNICIPALITY OF MALINSKA-DUBASNICA

### Pasara MK73



## Pasara MK 73

### Section 1: boat data

	<p><b>Motivation for the selection of the boat</b></p> <p>(the grid has the function of identifying and exposing the reason that motivated the selection of this specific boat for restoration and documentation)</p>
<b>Ethnographic / cultural significance</b>	<p><i>E.g. does the boat represent traditional boat types (e.g. bragozzo, batana, etc.) or traditional fishing techniques, crafts, traditions?)</i></p> <p>The renovated boat is part of the permanent exhibition of the Interpretation Centre in Malinska and will be used for demonstration sailing and participation in regattas and festivals of traditional boats.</p>
<b>Historical significance</b>	<p><i>Is the boat related to any historical event? (include sports scores of particular relevance, personalities, etc.)</i></p> <p>The boat was made by father and son Frane and Franjo Kraljić in the Malinska shipyard in 1985. Prior to the reconstruction, it was in navigable condition and moored in the port of Malinska. It was used for personal purposes, mainly for fishing. The boat is owned by Klaudija Koči.</p>
<b>Technical / nautical significance</b>	<p><i>Do the boat has particular design solutions, or represents nautical types of boats (e.g. Olympic classes, series, etc...), or the work of some famous designer?</i></p> <p>The boat belongs to the group of small open deckless pasara boats, distinguished by specific features typical for this kind of boat, a flat transom and a slightly curved bow with the stem inclined forward. She has a design classical for this kind and size of vessel – with a thwart at the bow, two transverse thwarts and longitudinal thwarts at the stern ending in a transverse thwart at the stern itself. There is a removable “deck” between the bow and forward transverse thwart for handling nets.</p>
<b>Replica</b>	<p><i>Is the boat an exact reproduction of a boat matching one of the above criteria?</i></p> <p>The boat MK 73 is not a replica, but an original boat from 1985.</p>

	Identification data
Current boat name	-
Current register number (if registered)	MK 73
Current harbour / location	Port of Malinska
Current owner	
Contact person / site	<p><i>Indicate name and contact data (e.g. tel., email, others) in order to have if needed further infos about the boat</i></p>

	Material data
Boat type / Traditional type	<p><i>Name of the traditional typology (e.g. bragozzo, batana, also giving further specification related to place) or boat's type (e.g. cutter, dinghy, etc)</i></p> <p>Pasara</p>
Original function	<p><i>Fishing, cargo or passengers transportation, leisure, sport,...</i></p> <p>Before restoration, the boat was seaworthy, berthed in the port of Malinska. She was used for leisure, mostly small fishing.</p>
Rig	<p><i>E.g. "al terzo", lateen, auric, etc.</i></p> <p>The rigging consists of the mast, standing rigging, lugsail and jib, yard, boom, bowsprit and running rigging.</p>
Length	4,10 m (length overall)
Breadth	1,57 m (breadth moulded)
Draught	0,52 m (from below the keel to the waterline of the hull)
Tonnage or weight (if known)	-

<b>Main materials and construction features</b>	<p><i>Indicate main construction features, e.g. hull materials and type of building (e.g. traditional wood building, oak wood, metal hull, etc.)</i></p> <p>Boat structural elements (keel, floors and frames, stem, sternpost, transom, bilge strakes, thwart risers, sheer strake (external and internal) caprail and bow and transverse thwarts) are made of oak. Hull planking is made of spruce, just like the stern longitudinal thwarts.</p>
	<b>Historical data</b>
<b>Date / period of construction</b>	<p><i>E.g. 1935 / the 50s, etc</i></p> <p>1985</p>
<b>Construction place / shipyard or builder</b>	<p><i>Indicate the place or if unknown the area, and the name of shipyard or shipbuilder</i></p> <p>Frane Kraljić from Malinska</p>
<b>Designer, if any</b>	<p>The shipbuilder Frane Krajić himself.</p>
<b>Historical presentation</b>	<p><i>Brief description of the life of the boat with reference to its original use and to events preceding the present restoration; indicate here also the previous names and register numbers, and previous owners, and restorations</i></p> <p>Before restoration, the boat was seaworthy, berthed in the port of Malinska. She was used for personal purposes, mostly small fishing.</p> <p>The previous and the first owner was Josip Pipa Matuča from Malinska, for whom the boat was built in 1985. The current owner is Klaudija Koči.</p> <p>Apart from regular maintenance, there were no significant previous renovations.</p>
<b>Bibliography / links</b>	<p><i>Give a bibliography of published books or articles, or links to Internet resources (e.g. sites, social) on this specific boat (not about type or in general)</i></p> <p>-</p>

## Section 2: technical description

<p><b>Metric data and shape of the hull</b></p>	<p><i>Indicate the salient measurements (in addition to those of length and width) and describe the general shape of the hull (e.g. sheer, length / width proportion, etc.)</i></p> <p>The hull length is 4.10 m, 4.62 m with the bowsprit. The (greatest) width is 1.57 m, the draught is 0.52 m at the stern, and the height in the middle is 0.81 m. The boat has 15 frames (frames F1 to F15) and the zero frame F0 fastened directly to the transom. Midships (theoretical main frame) is between the frames F8 and F9.</p> <p>The ratio of length and width <math>L/B = 2.6</math>, the ratio of width and draught <math>B/T = 3.0</math>, the ratio of length and draught <math>L/T = 7.9</math>, the ratio of length and height <math>L/H = 5.1</math>, and the ratio of width and height <math>B/H = 1.9</math>.</p> <p>The boat belongs to the group of small open deckless pasara boats, distinguished by specific features typical for this kind of boat, a flat transom and a slightly curved bow with the stem inclined forward.</p>
<p><b>Structural parts (keel and frames)</b></p>	<p><i>Description of the structure of the boat, also indicating the number and measures of the frames, and other structural parts</i></p> <p>Boat structural elements (keel, floors and frames, stem, sternpost, transom, bilge strakes, thwart risers, sheer strakes (external and internal), caprail and bow and transverse thwarts) are made of oak. Hull planking is made of spruce, just like the stern longitudinal thwarts.</p> <p>The keel, made of oak, stretches along the entire length of the boat and is approximately 3.07 m long. At the bow it connects with the stem, and at the stern it stretches to the end of the boat (the sternpost relies on it). The keel height is smaller at the bow, and larger at the stern, so the keel height outside the hull ranges from 14.5 cm at the bow, 17 cm amidships and 19.5 cm at the stern. The keel consists of two parts in height, so the mentioned heights include the false keel which is 5 cm high at the bow and 7 cm at the stern. The height of the garboard strake, which is 2 cm, should be added to get the total height of the keel. The keel is nearly rectangular in cross-section, 4.5 cm wide (4 cm along the floors). The floors, along with the stem and apron, and the stern massive and inner post are fastened to the keel with bolts, 8 mm and 10 mm in diameter.</p>

The stem, made of oak, is 1.74 m long, 7.5 cm wide at the top (14.5 cm wide with the apron), while outside the planks it is 6.5 cm wide above the rubbing strakes, 8.5 cm at the waterline, 9 cm in the stemson and 13 cm to the scarf. The radius of curvature of the stem is approximately 64 cm. The stem is 2.5 cm thick at the outer edge, widening towards the apron and the stemson reaching the thickness of the keel. The sternpost, made of oak, is fastened to the transom and relies on the keel. It is 76 cm long, 5.5 cm wide at the top, 7.5 cm wide at the waterline and 8.5 cm wide at the bottom, and it is 2.8 cm wide at the top (it has a trapeze cross-section and widens to the transom to 3.3 cm), 3 cm wide at the waterline and 3.5 cm at the bottom.

The boat has 15 frames (frames F1 to F15) and the zero frame F0 directly fastened to the transom. The frames consist of 3 pieces (floor, port and starboard frames). Reinforcements were built along two floors with additional top timbers added to multiple frames during restoration. Midships (theoretical main frame) is between the frames F8 and F9. Port and starboard bow frames are installed forward in relation to the frames (frames F10 to F15), while the port and starboard stern frames are installed towards the aft in relation to the frames (frames F1 to F9). Port and starboard frames are made of one piece, 6 to 6.5 cm wide and a nominal thickness of 2.5 cm. The frames narrow down from the bottom to the top (under the thwart risers they are 5 to 5.5 cm wide). The floors and frames are made of oak. The floors are made in one piece, 6.5 to 7 cm wide and 2.5 cm nominal thickness. The floors are wider (higher) in the middle and slightly narrow down towards the ends (5.5 to 6 cm). The frames F0 and F1 do not have a floor but the frames end at the apron. The frames F2 and F3 also end into the horizontal stern massive, but they have floors.

The bilge strakes are made of oak, 7.5 cm wide at the bow, 11 cm amidships and 7 cm at the stern. They are 2.3 cm thick. They stretch from the first to the fourteenth frame (F1 to F14). Each bilge strake is made of two pieces, with a vertical joint at the frame F7. They are fastened symmetrically on both sides of the frames, at the connections with the floors. Besides providing longitudinal strength, the stringers serve as side boundaries for the limber boards.

The caprail, made of oak, relies on the upper edges of external and internal sheer strakes. The caprail is 9.5 cm wide at the bow, 9.5 cm amidships and 10 cm at the stern, with thickness of 2.2 cm. The port and starboard side caprail is made of two pieces with open V scarves. The scarf on the starboard side is made before the frame F10, and on the port side after the frame F11. The ends (heads) of the

	<p>caprail fore parts end right next to the stem, while at the fore part they are extended, 5 cm wide, and rounded at the end (they stretch 3 cm behind the forward edge of the stem). The ends (heads) of the caprail stern parts reach the transom, i.e. the aft side of the transom, in the width of 4 cm (a part of the caprail is built into the transom).</p>
<p><b>Planking (external / internal)</b></p>	<p><i>Description of the planking, with measures, and type of waterproofing (e.g. caulking, epoxy, other).</i></p> <p>The planking, 2 cm thick, is made of 9 planks (planks from A to I), symmetrically on both sides, from the keel to the external sheer strake. The planks are made of spruce. The planks are fastened to the floors, frames and added top timbers with galvanized nails, 50 x 3 mm, and partially stainless steel wood screws, dimensions 40 x 5 mm. The heads of plank fore parts are skewed at the bow in longitudinal and transverse cross-section, so they end up right next to the stem. The heads of stern planks aft parts end at the transom, i.e. massive element at the joint between the keel and the transom. The heads of the fore and aft parts of planks are vertical at the mutual joints.</p>
<p><b>Deck and openings</b></p>	<p><i>Description of the deck and the number and size of the different openings</i></p> <p>Boat is open, deckless (with only thwarts). The boat has a thwart (forecastle deck) at the bow, transverse central thwart and a stern thwart consisting of two longitudinal thwarts and a stern thwart.</p> <p>The bow thwart is roughly triangular in shape, with sides following the curvature of the hull at the bow. It stretches to the frame F14. It is 44.5 cm wide (longitudinally), 71.5 cm long at the aft part, and ends in the bow with its top 7.5 cm wide. The bow thwart consists of two glued oak boards, 3 cm thick.</p> <p>The central thwart towards the bow, made of oak, is located between the frames F10 and F11 (1.39 m from the top of the stem), it is 1.27 m long, 20 cm wide and 5 cm thick. In the middle of the thwart there is a hole for the mast, 7.5 cm in diameter (the centre is 1.49 m away from the top of the stem).</p> <p>At the stern, the aft part of the thwart has two supports (flat beams). The front support is attached between the frames F1 and F2 (closer to the frame F2), 4.5 x 4 cm in cross-section. The aft support is attached to the transom, 4.5 x 4 cm in cross-section. There is a solid wood support, 34 cm high, 28 cm wide at the top (the support is cut to the thwart riser on the side, 6 cm) and 2.8 cm thick at the forward part of the longitudinal thwarts on each side. The aft part of the stern</p>

	<p>thwart is 43.5 cm long (longitudinally) and 90 cm wide at the stern along the transom. The side (longitudinal) parts of the stern thwart are 1.30 m long and 26 cm wide (forward) and 27 cm towards the stern. The distance between the longitudinal thwarts at the forward side is 78 cm, and towards the stern part of the thwart 60 cm. The central part of the stern thwart (between the longitudinal thwarts) consists of two boards, 51 cm wide (forward) and 38 cm wide along the transom. The stern thwart is 2.5 cm thick and made of spruce.</p>
<p><b>Sails and rig</b></p>	<p><i>Describe in detail and provide the type (e.g. "al terzo", lateen, auric, Marconi, etc.) and other features of the sails, and of the fixed and running rigging</i></p> <p>The rigging consists of the mast, standing rigging, lugsail and jib, yard, boom and bowsprit and the running rigging.</p> <p>The boat has a 4.28-m long mast, located at 1.49 m from the forward edge of the stem. The lower mast is 3.70 m long to the hoop. The mast is made of spruce (glued from two pieces). The mast diameter at characteristic cross-sections is the following: 6.3 cm at the foot, 7.8 cm at the thwart level, 7.2 cm at 1/4 length from the thwart, 7 cm at half length, 6.5 cm at 3/4 length, 6 cm at hoop level, 4 cm at the top. The mast foot is square in cross-section, with dimensions 3.5 cm x 3.5 cm. At the top of the mast there is a truck, 8 cm in diameter and 7 cm high (cylindrical in the first 4 cm of its length, and then turns into a cone at the top). Immediately above the lower mast, there is a hoop, 6 cm high and 4 cm in diameter. It is made of stainless steel sheet, 3 mm thick, and has four rings 6 mm in diameter welded on it. There are three double cleats installed on the mast above the thwart, one on its forward part and two on the aft part (at approximately 45° in relation to the centreline).</p> <p>The bowsprit, made of spruce, is 0.77 m long, conical in layout, 9 cm wide at the after end 30 cm in length, then gradually narrows down to 6 cm in the middle, then turns into a round cross-section, having 4 cm in diameter at the end. The groove for inserting it into the stem is made 8 cm from the after end of the bowsprit, 8 cm long and 3.5 to 2.5 wide (the groove is conical). In the vertical plane, the bowsprit is 6 cm wide at the after part, then it slightly narrows down to 5.5 cm in the middle, and towards the top, as already mentioned, it turns to a round cross-section. The bowsprit is fastened to the stem with two stainless steel bolts, 8 mm in diameter.</p> <p>The yard is 5.10 m long. It is made of spruce and glued from two pieces. The yard diameter at characteristic cross-sections is the following: 5 cm at the bottom,</p>



	<p>6 cm at 1/4 length, 6.5 cm at 1/3 length, 6.5 cm at half length, 6.5 cm at 3/4 length and 5.2 cm at the top.</p> <p>The boom, made of spruce, is 3.60 m long and glued from two pieces. The boom diameter at characteristic cross-sections is the following: 4.5 cm at the fore part, 5.5 cm at 1/4 length, 5.5 cm at half length, 5 cm at 3/4 length and 4.5 cm at the top.</p> <p>The boat is equipped with a lugsail and an auxiliary sail, jib. Both sails are made of canvas (190 g/m<sup>2</sup>). The main sail surface is 9.5 m<sup>2</sup>, while the auxiliary sail surface is 2.9 m<sup>2</sup>. The sails are traditionally made with the sails hemmed with rope (luff line 10 mm in diameter), except at the leech, with vertical sail panels. They are fastened to the yard and the boom with beige braided polyester rope, 6 mm in diameter. The main sail has one reef at 77 cm from the lower edge.</p> <p>Standing rigging consists of two shrouds and a forestay. The shrouds are made of beige braided polyester, 12 mm in diameter. The forestay is made of beige braided polyester, 6 mm in diameter. The running rigging consists of a single block and yard halyard (12 mm in diameter), boom fore part sheet (10 mm in diameter), the main sail sheet made from a tackle consisting of the upper single block with an eye and the lower double block, and a rope 12 mm in diameter, jib halyard (10 mm in diameter) and jib sheet (10 mm in diameter). All runningrigging blocks are made of wood and brass, and the ropes are made of beige braided polyester.</p>
<p><b>Rudder and other steering elements</b></p>	<p><i>Describe the type and material of the rudder (e.g. tiller, wheel) and the other steering parts.</i></p> <p>The rudder is made of oak. The rudder blade is 46 cm wide at its widest part, 43 cm at the bottom (flat part), 16 cm at the waterline, 13 cm at the top before the part where the tiller is placed. The rudder blade consists of several planks, 3 cm thick. The running surface of the rudder blade is 0.82 m, and the total height to the top of the rudder is 1.36 m. The approximate running surface of the rudder blade is 0.30 m<sup>2</sup>. The length of the rudder blade under the keel is 0.33 m. The top of the rudder stock is 6 cm high, 9 cm wide and 2 cm thick with rounded edges. It is made so the tiller is wedged on it. There are two stainless steel fittings installed on the rudder at a distance of 84 cm. The upper fitting (male) is installed at 9 cm from the top of the rudder stock (without the part to which the tiller is wedged), and the lower fitting (female) is installed at 82 cm from the top of the rudder stock, i.e. 39 cm from the bottom of the rudder. The tiller is made of yew wood</p>

	<p>and is 90 cm long. The tiller is 5 cm wide at the after end and for the first 23 cm (vertically), then narrows down to 4 cm, and turns into a round shape at the end, 3 cm in diameter. In the horizontal plane, it is 7 cm wide (thick) at the after end and for the first 23 cm, then narrows down to 4 cm, then turning into a round cross-section, as was previously mentioned, 3 cm in diameter. At the after end of the tiller, 6.5 cm from the end, there is a groove, 9 cm long and 2.2 cm wide, for wedging the tiller on the top of the rudder stock.</p>
<p><b>Other significant elements</b></p>	<p><i>E.g. inboard or outboard engine, changes made to the original hull, presence of incongruous elements, elements inserted for technical or regulatory reasons, etc.</i></p> <p>The boat was restored in her original form, except that during restoration modern tools were used and materials different from those used at the time the pasara was built were coated with suitable coatings (e.g. stainless steel).</p> <p>The boat is driven by oars and sails, or an outboard engine if necessary.</p>
<p><b>Previous restorations</b></p>	<p><i>Indication and description of the previous restorations, if any, with indication of year, place/shipyard, replaced parts and work, if known</i></p> <p>There were no previous renovations or reconstructions, except for regular maintenance. The boat remained true to the original.</p>

## Annexes to the technical description

Add a plan of the boat, or sketch, not important if made by CAD or laser scanner or by free hand, but mandatory with 3 views (side, front, top), and in addition 1 side view with sail/s and rig, views of details if important; all the views with the reference measures

Plan

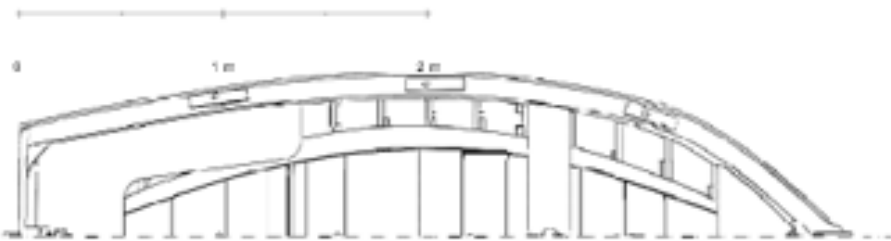
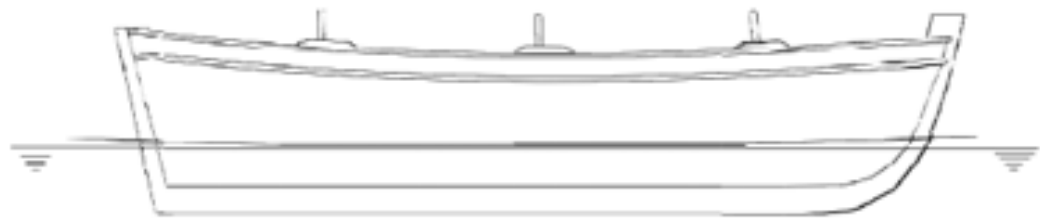

General arrangement

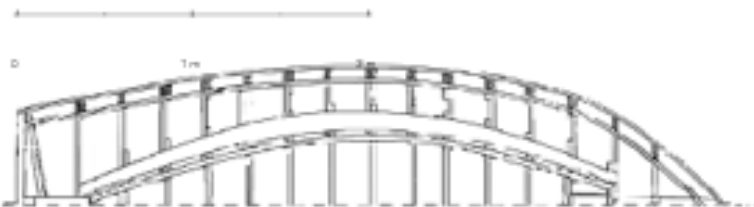
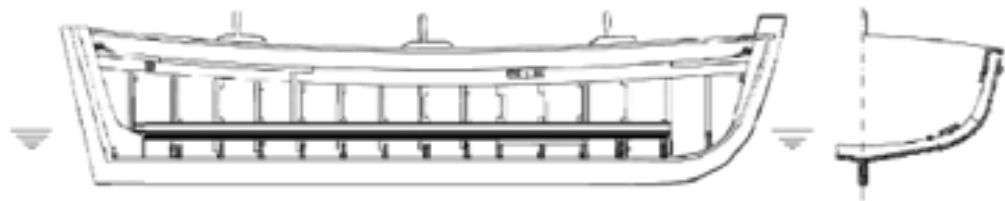

Construction drawings

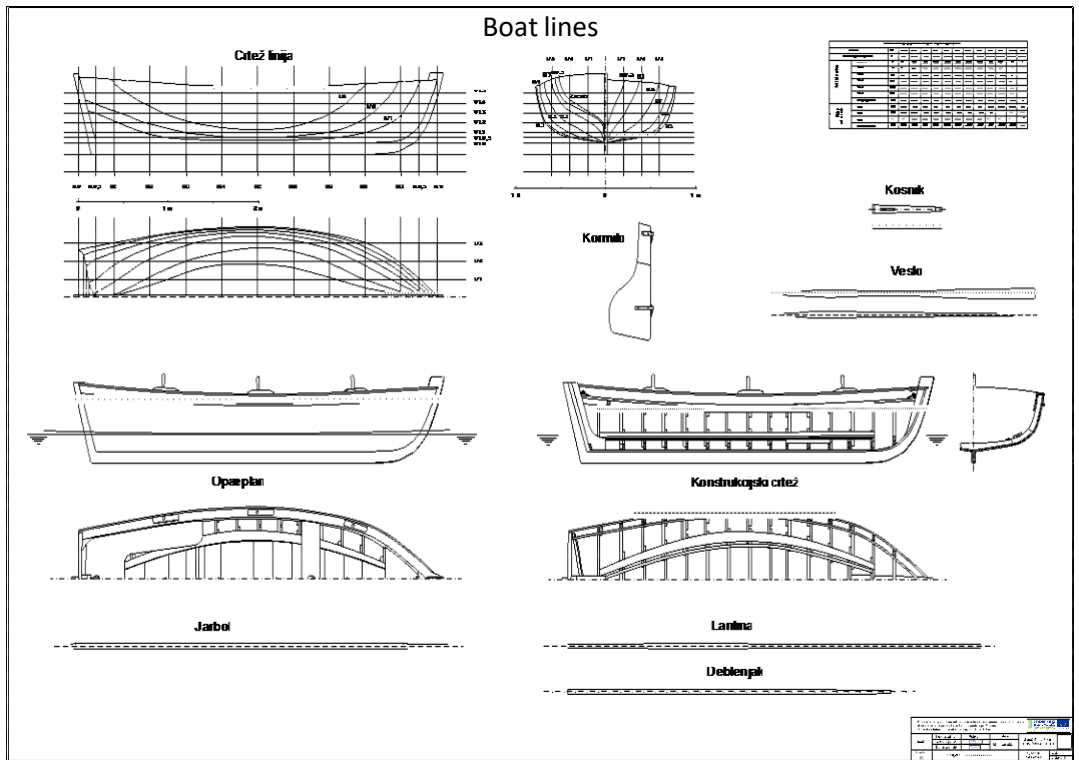
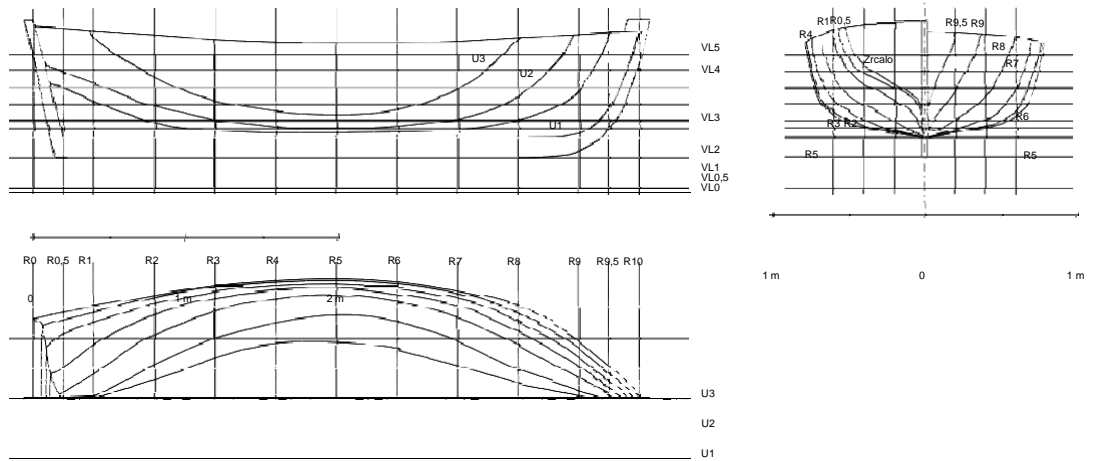

General arrangement, construction drawings, boat lines, rudder, tiller, oars, mast, bowsprit, yard, boom

Insert a reduced plan of the boat in the frame below

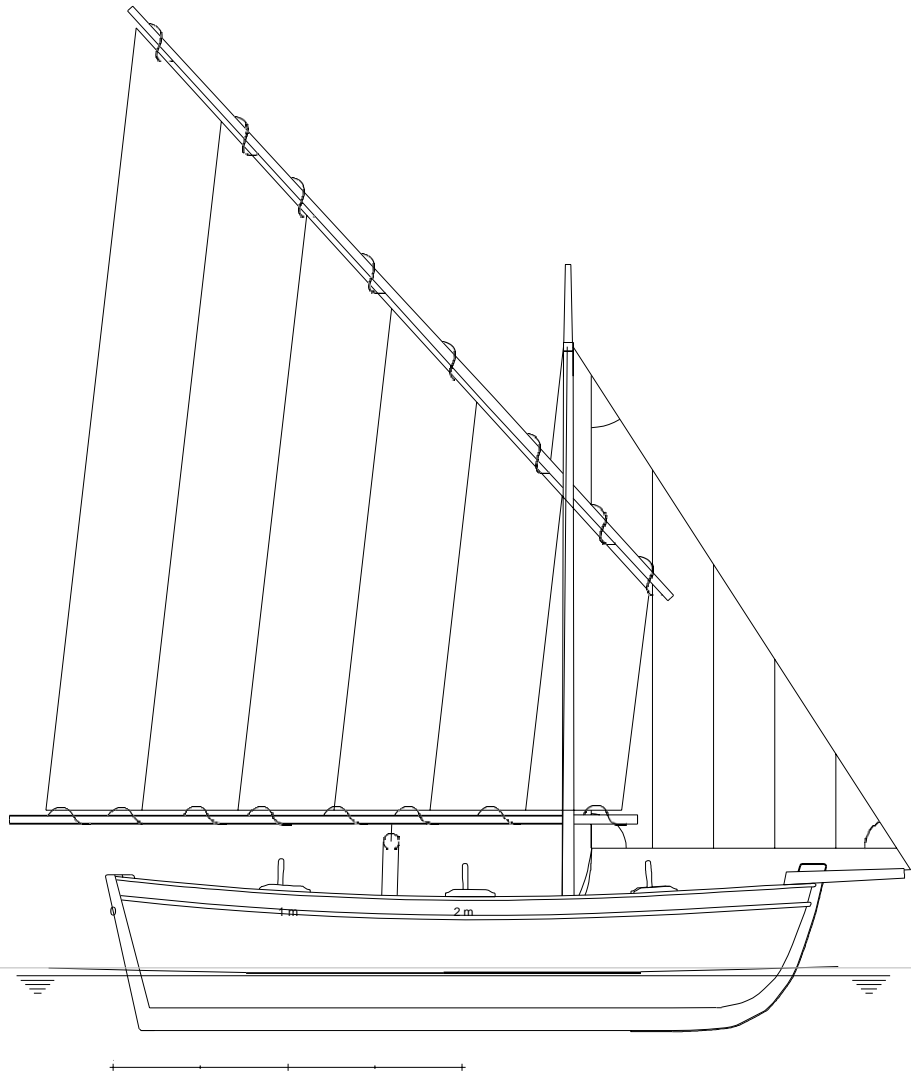

Insert a photo with a general view of the boat in the frame below



**Name of the compiler**

Prof. Robert Mohović, PhD  
Igor Knapić, M.Sc.nav.arch.

**Date of compilation**

15. 11. 2021.

## **PP 3 - ASSOCIATION AND ECOMUSEUM "HOUSE OF BATANA"**

### **Batana Peicia**



## Section 1: boat data

<b>Motivation for the selection of the boat</b>	This boat was chosen in particular because an important restoration was urgently needed.
<b>Ethnographic / cultural significance</b>	The boat represents a type of traditional boat, in particular, in this case, the batana, typical of Rovinj-Rovigno.
<b>Historical significance</b>	<p>Rovinj's batàna, with the Rovinj batièl, the Venetian gondola, the Neretva trupa, the Komiža sandula and many other little boats belong to the numerous families of flat-bottomed boats. The origins of such boats can be found in the prehistoric period, in the designs of rafts and dugouts from wooden hulls (monoxylyon). A flat-bottomed vessel was perfect for sailing shallow waters – lakes, river estuaries, lagoons and shallow sea coasts. It appears not only on the Adriatic coast, but throughout Europe and around the world. The vessels themselves were subjects of extensive cultural exchanges, so there were many exchanges in design which became universal with ever present specific expressions, 'with accents'. This was also the way with the development of Rovinj's batana. In the Middle Ages the existence of the batana was noted in the Italian region of Marche. They, together with the flat-bottomed boats of the Trasimeno and Varano lakes, influenced the design of the batana in the lagoons of Venice. Meant to be used for coastal fishing, the batana spread from the lagoons to the northern Adriatic coast, to Istria and Rovinj, Krk, Rab and Zadar. Although this craft was invented long ago, Rovinj's batana in the written and painted sources of Rovinj is only mentioned much later, as late as the 19th century.</p> <p>According to legend, the name batàna is connected to the Italian sound of the verb of battere (to bang, beat or wallop), which resembles the sound of the boat's</p>



	<p>flat bottom as it hits the waves. In the Rovinj dialect however, the little boats that are able to go out onto the open sea, are referred to with the saying: “Bòne da bàti màr!” (“Good to enough to beat the sea!”). According to other opinions, the boat’s name comes from the ancient term batto. This was the name given to small rowing boats from the 14th century, the forerunners of today’s little boats. In line with this interpretation, the term was then borrowed from an old Anglo-Saxon word bat, from which later came the English word boat. Until the 1920s, there were a relatively small number of batana boats in Rovinj, because it was used only for certain types of inshore fishing. With the start of the use of paraffin lamps and the expansion of the use of drag-nets or trata for the night fishing of sardines, their numbers increased considerably. The batana’s golden age was enjoyed during the 1960s, with the use of the Tomos outboard motor. This two-stroke 4 hp outboard motor was made in nearby Koper in Slovenia. With this the batana became faster and more flexible and the fishing boat became the favourite craft for fun and recreation. Families in Rovinj who did not own a batana were rare, as were those who did not take their batana out to sea for swimming trips in the summer months. In winter it was also rare that those batanas did not go fishing and so tightening the household budgets. Towards Easter, it was difficult to count the batanas which their owners used for catching squid for the traditional holiday meal. To date the Port Authority in Rovinj has registered 241 batanas.</p>
<p><b>Technical / nautical significance</b></p>	<p>The boat has a very simple design solution that is reflected above all in its flat bottom. The second significance is the lug sail which is used to</p>
<p><b>Replica</b></p>	<p>The boat is a smaller version of the traditional batana boat, an innovation designed for children. It is a smaller replica of the traditional batana boat.</p>

	<p><b>Identification data</b></p>
--	-----------------------------------

<b>Current boat name</b>	Peicia - batana
<b>Current register number (if registered)</b>	RV 1642
<b>Current harbour / location</b>	Port of Rovinj – Rovigno
<b>Current owner</b>	Association “The house of batana”
<b>Contact person / site</b>	

	<b>Material data</b>
<b>Boat type / Traditional type</b>	BATANA
<b>Original function</b>	Fishing, passengers transportation, leisure, sport, vela.
<b>Rig</b>	Al terzo
<b>Length</b>	3.88 m
<b>Breadth</b>	1.35 m

<b>Draught</b>	10 cm
<b>Tonnage or weight (if known)</b>	4 persons cca 320 kg
<b>Main materials and construction features</b>	<p>Traditional wood building.</p> <p>Batana is built from three types of material: oak, fir or spruce. In exceptional cases, when we cannot get spruce or fir of the required length, larch can also be used, but in that case the batana turns out to be much heavier. Oak is used for the front and stern loom, for the ribs and the rib extension, for the clamps and the cleats, for the keel, for the pad and thumb. Spruce, fir or larch is used for planking, for covering bow and stern, for center bench, for rowlock.</p>

	<b>Historical data</b>
<b>Date / period of construction</b>	2015
<b>Construction place / shipyard or builder</b>	Rovinj-Rovigno, Squero
<b>Designer, if any</b>	/
<b>Historical presentation</b>	Based on the principles of the Convention for the safeguarding of intangible heritage, the House of batana approached the safeguarding of boatbuilding with a view to adapt the boats to specific local needs. In 2015 the strategy of the Association oriented towards transmission of knowledge. In this sense the decision was made to make a small batana which would be suitable for childrens'

	worskshops. This is how the Peicia batana was born. It is a replica of traditional batana boat with all its characteristics but in a smaller scale. The boat has always been owned by the "Kuća o batani - Casa della batana" Association, it had no other registration numbers and this is the first restoration.
<b>Bibliography / links</b>	<p>Libero Benussi, "Rovinjska batana i njezino jedro – La batana rovine e la sua vela", Rovinj-Rovigno Udruga – Associazione "Kuća o batani - Casa della batana", 2007.</p> <p>Glossary; batana.org</p>

## Section 2: technical description

<b>Metric data and shape of the hull</b>	3.88 m – 1.35 m
<b>Structural parts (keel and frames)</b>	<p>12 ribs</p> <p>Fir cladding</p>
<b>Planking (external / internal)</b>	Planking – Fir / waterproofing - caulking
<b>Deck and openings</b>	<p>Bow deck - 167 cm long</p> <p>Stern deck - 62 cm long</p> <p>Banquet - 129 cm x 4 cm x 21.5 cm thick (spruce)</p>
<b>Sails and rig</b>	Vela al terzo, burina, scotta, caricabanda

<p><b>Rudder and other steering elements</b></p>	<p>Rudder - oak</p> <p>Oars - ash</p> <p>The oars are 285 cm long. Maximum width 12.5 cm. Diameter from 3 to 4.5 cm</p>
<p><b>Other significant elements</b></p>	<p>/</p>
<p><b>Previous restorations</b></p>	<p>/</p>

## Annexes to the technical description

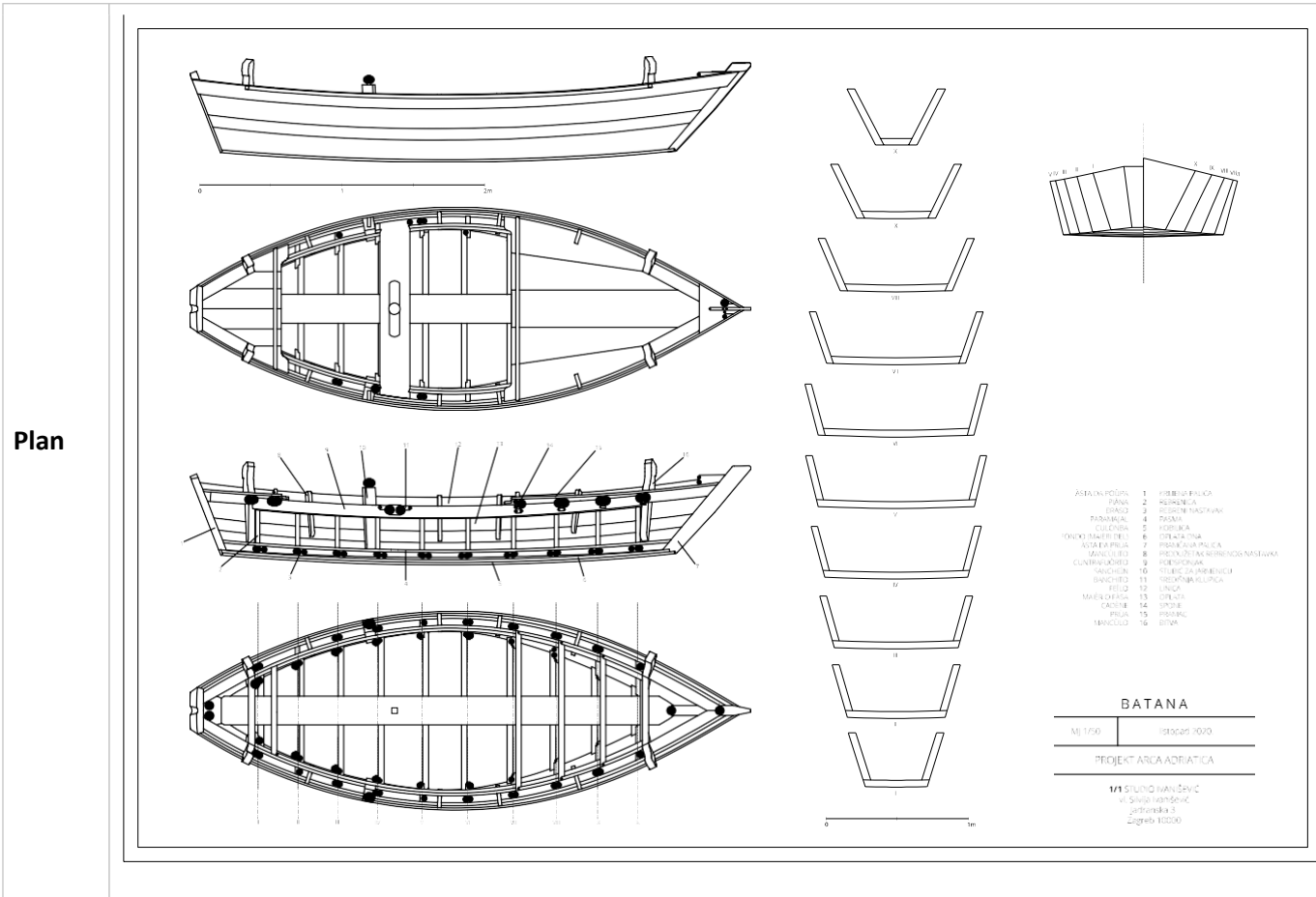

<b>Name of the compiler</b>	Tamara Nikolić Đerić, Nives Giuricin, Alvisè Benussi
<b>Date of compilation</b>	15.10.2021.

Insert a reduced plan of the boat in the frame below

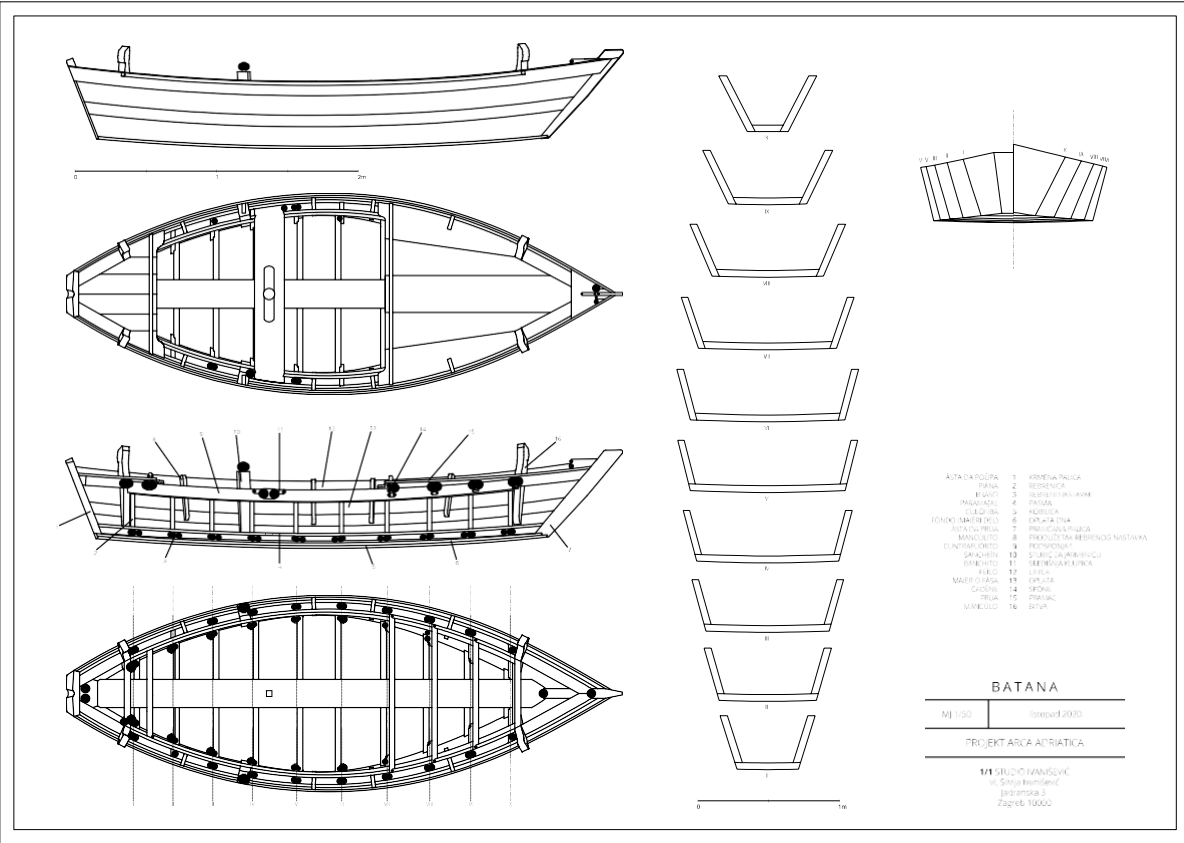

The drawing includes a side view, a top-down view of the hull, a detailed view of the deck structure, and a bottom-up view of the hull. A vertical stack of 16 cross-sections (I to XVI) shows the hull's profile at different points. A legend on the right lists the parts and their corresponding numbers.

ALTA DA POLDA	1	ROBETA PALCA
PAJANA	2	RESEBENCA
REKOTI	3	RESEBENKA KANE
PAJANOVKA	4	PASTVA
ČELOVINA	5	ROBETA
ČELOVINA	6	ČOKVAČINA
OSTA DO PRVA	7	PROJECIJA PALCA
MANJLOČE	8	PROJEKCIJA RESEBENKE NASTAVKA
ČIČAKI (ČIČKI)	9	RESEBENKA
ČIČAKI (ČIČKI)	10	ČIČAKI (ČIČKI)
ČIČAKI (ČIČKI)	11	ČIČAKI (ČIČKI)
ČIČAKI (ČIČKI)	12	ČIČAKI (ČIČKI)
ČIČAKI (ČIČKI)	13	ČIČAKI (ČIČKI)
ČIČAKI (ČIČKI)	14	ČIČAKI (ČIČKI)
ČIČAKI (ČIČKI)	15	ČIČAKI (ČIČKI)
ČIČAKI (ČIČKI)	16	ČIČAKI (ČIČKI)

**BATANA**

M 1:50      10000

PROJEKT ARCA ADRIATICA

STUDIO HANUSIĆ  
 v. Šimunićeva 2  
 10000 Zagreb

## **PP 4 - MUNICIPALITY OF CERVIA**

### **Lancia Assunta**





## Section 1: boat data

### **Etnographic/ cultural significance**

The Assunta boat, built in 1925, is a spear armed with a trapezoidal sail, locally called “vela al terzo”, which for its uniqueness is THE FIRST BOAT IN ITALY declared of particular artistic and historical interest by the Ministry for Cultural Heritage with a decree of 3 February 1997. The boat belongs to the Lancia Romagnola type and was used since the early 1900s, by the Garbin family of Cattolica, as a fishing boat with a third sail. It was the most characteristic type of the port of Cervia and the upper Adriatic (in the photos of the port from the early 1900s the same Assunta is depicted together with others that have been completely similar which have been destroyed).

Traditional boat of Adriatic Sea

### **Historical significance**

The boat has been moored in the port of Cervia since before the last world war, it is the only one to have survived the destruction of the Cervesi boats by German army troops pursued by the advance of the allied troops. He has participated in all editions of the local sea festivity, named “sposalizio del Mare” and in all historical boats’ regatta “Cursa di Batell”, and events of the regional traditional boat association, Mariegola.

### **Technical/nautical significance**

In 1996 the Institute of Naval Archeology and Ethnology of Venice chaired by Mario Marzari certified the historical importance of the Lancia Assunta, "as the only Lancia Romagnola present in the Adriatic built before the last world war and as the only army according to the sailing tradition of 'epoch'. On 3 February 1997, on the basis of the declarations made by Marzari, the then Ministry for Cultural and Environmental Heritage decreed, the first case in Italy, that the Assunta lance constitutes an asset of particular artistic and historical interest pursuant to articles 1 and 3 of law 1089 and placed the Romagna lance under legal protection.

### **Replica**

It is not a replica

### Identification data

<b>Current boat name</b>	ASSUNTA
<b>Current register number (if registered)</b>	/
<b>Current harbour/location</b>	PORT OF CERVIA, MILANO MARITTIMA SIDE berth assigned by the Superintendence for cultural heritage of Bologna
<b>Current owner</b>	[REDACTED]
<b>Contact person/site</b>	[REDACTED]

### Material data

<b>Boat type/Traditional type</b>	Lancia Romagnola
<b>Original function</b>	Fishing boat
<b>Rig</b>	"al terzo"

**Lenght** 8,60 m

**Breadth** 2,48 m

**Draught** 0,8 m

**Tonnage or weight** 30 tons

**Main materials and construction features**

From a detailed study of the shapes of the boat it was possible to trace the shipwright who conceived and built the hull in 1925; in fact, the lances did not have a real constructive prototype but each craftsman customized them as he pleased and the Assunta reports the characteristics of the Patrignani shipyard in Cattolica. To give the boat solidity and safety, the shipwright used three different types of wood in the construction:

- fir, a lighter and less noble wood, was used for the construction of the deck, the mast and the yards;
- larch, a more resinous and waterproof wood, for the planking;
- oak, a more robust and resistant wood, for the keel and the frames.

**Historical data**

**Date/ period of construction** 1925

**Construction place/shipyard or builder** Shipyard Patrignani Cattolica RN

**Designer, if any**

## Historical presentation

The Assunta is a spear, a typical Romagna fishing boat armed with sails “al terzo”, built in the distant 1925 in the prestigious Cattolica shipyards where, at the time, an important part of the boats used for fishing and for transport along the coasts of the middle and upper Adriatic.

The Lancia has an overall length of 8.50 m excluding the rudder, a maximum width of 2.49 m and a draft of 58 cm with the rudder raised.

The rig is made up of the typical local “al terzo” sail, that measure 58 m<sup>2</sup> and two jibs of 4 and 2.5 m<sup>2</sup> respectively which are hoisted mainly in the carrying gaits through the use of a bowsprit.

The purple colors and designs that still adorn the sails and hull of the Assunta today are the same ones that, back in 1925, identified the "Garbin" family. Garbin was in fact the fisherman from Cattolica who armed and baptized the Assunta, giving it this name in memory of the day the hull was launched.

In fact, it is said that the Assunta was lowered into the water for the first time on August 15, 1925, on the feast day that traditionally commemorates the Assumption of the Virgin into heaven, hence the name of Assunta.

Garbin was a skilled fisherman whose challenges with the sea are still told today. In particular, he remembers when alone, fishing off the coast of Cesenatico, he was caught by an extraordinary storm coming from the north wind. Against the violence of the sea Garbin could do nothing but knock down the mast with an ax and wrap the deck with the sail, building a precarious shelter against the breakers. When, after a day of violent storm, the sea had calmed down, the Assunta found herself stranded under the mountains of Pesaro from where, having repaired the damage suffered, she could resume the sea.

Subsequently the boat was purchased by Luigi Tiozzi and its moorings were transferred to Cervia, where after a short fishing period it remained unused for a long time due to the war events that resulted in the Second World War.

The war and the bombings caused very serious damage in the Adriatic ports but, more than the planes, it was the divisions of the German army, pressed by the advance of the allied forces, to rage on the fishing boats; in the desperate retreat, the order given to the military was to send all the hulls capable of sailing to the bottom.

The Assunta survived the fate of the war by remaining moored in one of those smaller and more hidden canals that still today connect the salt pans of Cervia to the sea.

But the fascination exerted by the red colors of the sails and no less by the excellent and unaltered sailing qualities advised Luigi Tiozzi to transform the Assunta, taking advantage of an expanding tourism, from an old fishing boat into a noble "walking" boat.

It is also said that Admiral Aliprandi, former vessel commander during the First World War and a close friend of Grazia Deledda, greatly enjoyed her virtues and used to define the Assunta as an "excellent shell".

At the end of the fifties of the last century the Assunta was sold by Luigi Tiozzi to Mr. Mario Collina of Cervia who used it for a few years mainly in the summer months as a walking boat.

After a few years, the launch was sold to Mr. Pasquale Cicogna of Milan who had it registered by the Port Authority of Cervia from fishing boat to pleasure sailing boat, entrusting it to the care of a skilled Cervese sailor Augusto Giulianini; the boat was used little and therefore Giulianini was almost immediately commissioned to find a buyer interested in its purchase.

On March 24, 1975 the Cervese fisherman Maraldi Ruggero, interested in the purchase of the launch and its conversion into a fishing boat, agreed with Giulianini to become the owner of the Assunta for the sum of 170,000 lire; but then, as the costs to be incurred to replace the sails and masts with an engine suitable for fishing were huge, Maraldi fortunately did not complete the purchase and saved the launch from the transformation from a traditional boat to a motorized fishing boat.

It was only at the end of the summer of 1975, and almost by chance, that Pier Paolo Marini and Giancarlo Penso rediscovered the beauty, so much so that they decided that the Assumption should have recovered its ancient splendor and resumed navigation and sailing fishing.

The work that was entrusted to the Cervese shipwright Domenico Fioravanti lasted a long time because time had seriously worn the hull.

The boat was transported inside the Fioravanti shipyard where, after having cleaned it of all the ballast and the coats of paint that had followed one another over the years, all the parts that made up the deck and the planking of stern, therefore, using the same original arboreal essences, the tables deteriorated by time were replaced.

For the assembly of the same, the traditional methods of the Romagna shipbuilding were used, that is, all the boards were shaped and bent with fire, nailed with galvanized nails and caulked with tow.

The sails were now burnt by the sun and salt so for their packaging they returned from the historic sailmaker of Cattolica Maria called "manghina" who, now eighty, made a set of new sails equal to those that had been commissioned in 1925 from Garbin.

The results amply repaid, with their succession, the efforts made; the Assumption was, in fact, slowly regaining all the beauty and grace that was only apparently lost. The sails in cotton, the natural colors, the timber of the hull, every detail was taken care of with order and systematicity.

After three years of work, the Assumption was once again able, in the hands of the current owners, Paolo and Michele Marini, to sail and fish as it had been launched many years earlier, on the day of the Assumption of the Virgin.

In 1996 the Institute of Naval Archeology and Ethnology of Venice chaired by Mario Marzari certified the historical importance of the Assunta launch, as the only Romagna launch built before the last world war and as the only army according to the sailing tradition of the time.

On 3 February 1997, on the basis of the declarations made by Marzari, the then Ministry for Cultural and Environmental Heritage decreed, the first case in Italy, that the Assunta lance constitutes an asset of particular artistic and historical interest pursuant to articles 1 and 3 of law 1089 and placed the Romagna lance under legal protection.

In 2001 it was necessary to subject the lance to a second restoration operation to fix above all the parts that had not been restored in the previous restoration due to the excellent state of conservation.

This second restoration, carried out under the supervision of the Superintendence for the Historical, Artistic and Ethno-anthropological Demo of Bologna was always entrusted to the Fioravanti shipyard in Cervia.

The restoration consisted in replacing part of the bow frames and a large part of the planking of the bow of the boat, while the deck and the stern were only caulked. On the occasion of this restoration, the boat was also equipped with a new mast.

**Bibliography/  
links**

STORIA E RACCONTI DELLA LANCIA ASSUNTA a cura di Michele Marini e Stefano Medas

## **Section 2: technical description**

<b>Metric data and shape of the hull</b>	Vertical bow and stern
<b>Structural parts (keel and frames)</b>	Boat made with planking
<b>Planking (external / internal)</b>	Planking in larch, covered in fir and ordered in oak
<b>Deck and openings</b>	
<b>Sails and rig</b>	Sail "al terzo" in cotton painted with soil
<b>Rudder and other</b>	Rudder bar made of larch
<b>Other significant elements</b>	18 hp farymann inboard engine from 1971
<b>Previous restorations</b>	1981 Cantiere Fioravanti Cervia; 2001 Cantiere Fioravanti Cervia.

## Annexes to the technical description

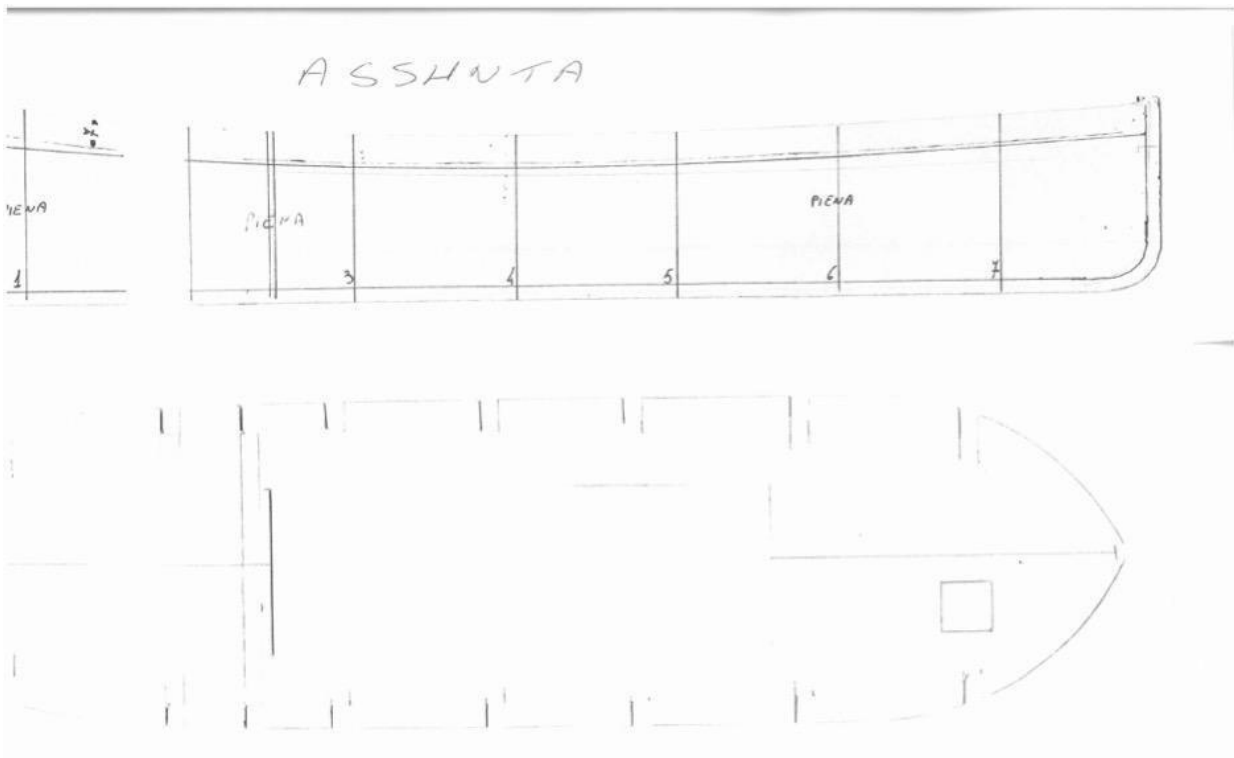



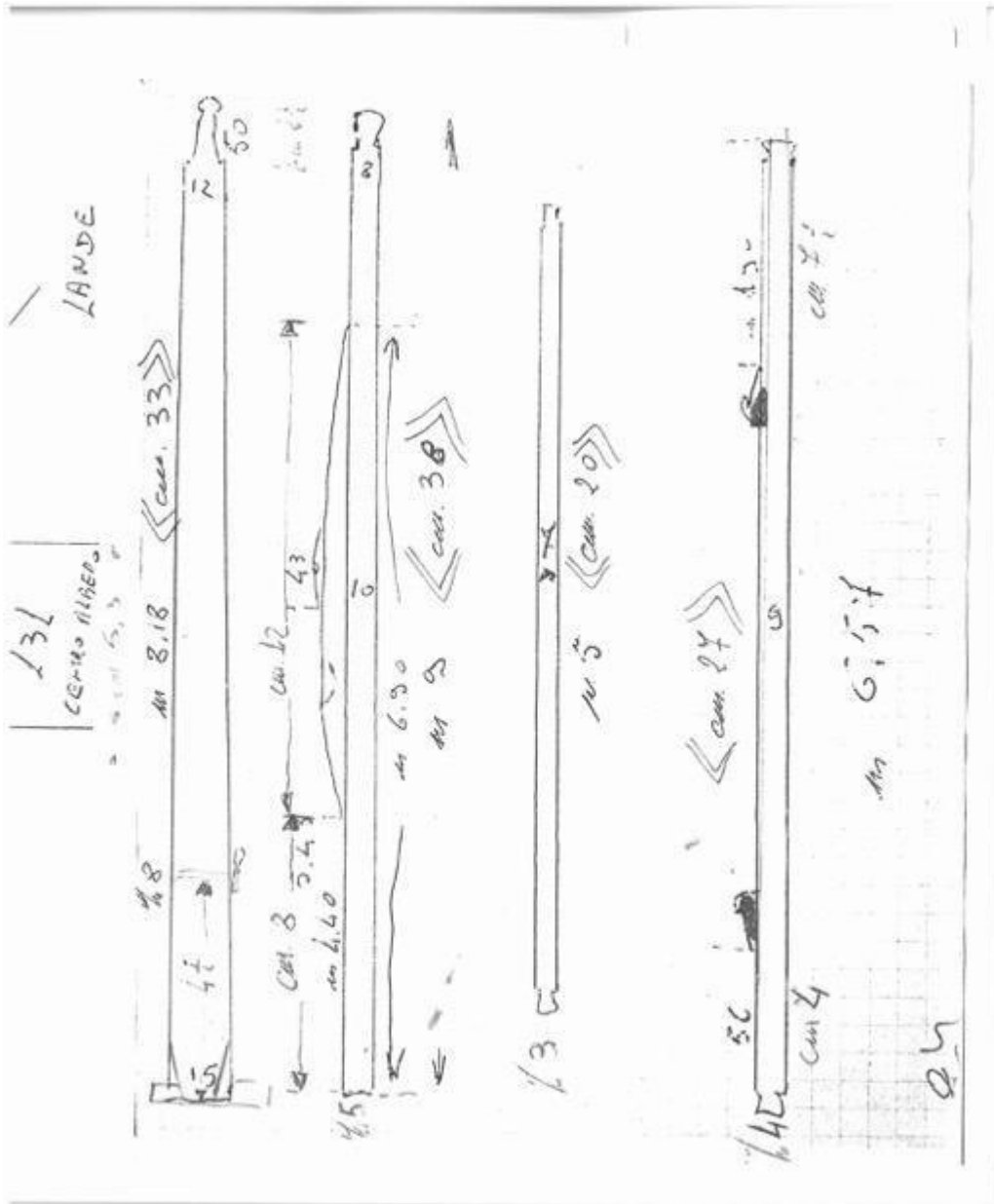

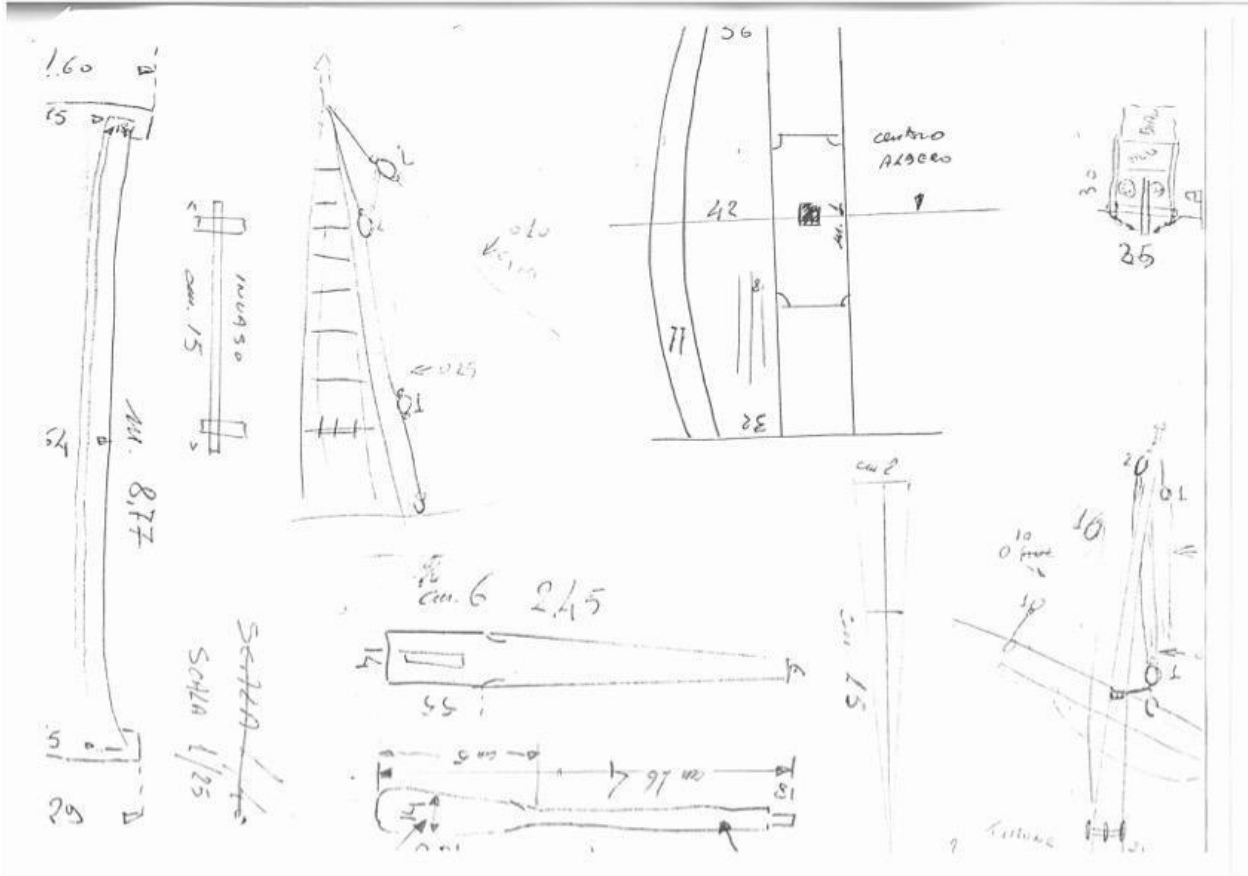

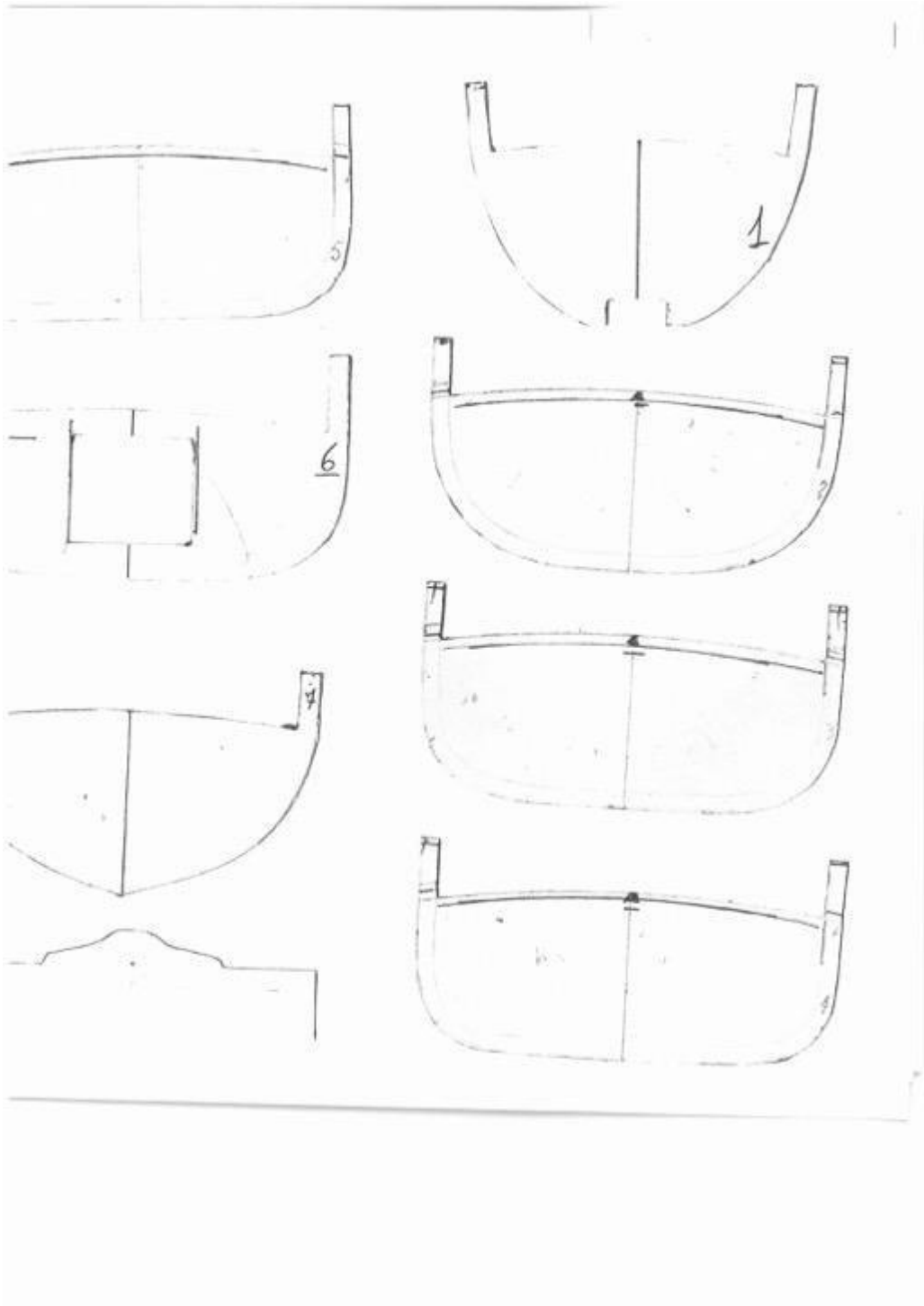

MODULANO  
8 CA - 55



MOD. 5

*Ministero per i Beni Culturali e Ambientali*

UFFICIO CENTRALE PER I BENI ARCHEOLOGICI  
ARCHITETTONICI ARTISTICI E STORICI

IL DIRETTORE GENERALE

VISTI gli artt. 1 e 3 della legge 1.6.1939, n.1089  
sulla tutela delle cose di interesse artistico o storico;

VISTO il Decreto Legislativo 3 febbraio 1993, n.29;

VISTA la documentata proposta di vincolo formulata dal  
competente Soprintendente con nota n.8333 del 5.12.1996;

RITENUTO che la lanca "Assunta", del 1925 lunga 8,50m.,  
larga 2,18, puntuale di 0,73 m., riveste particolare interesse  
artistico e storico ai sensi della citata legge per i motivi  
contenuti nella relazione storico-artistica allegata che fa  
parte integrante del presente decreto;

DECRETA:

La lanca individuata nelle premesse e descritta  
nell'allegata relazione storico-artistica, è dichiarata di  
particolare interesse artistico e storico ai sensi degli  
artt. 1 e 3 della legge 1.6.1939, n.1089 e, come tale, è  
sottoposta a tutte le disposizioni di tutela contenute nella  
legge stessa.

Il presente decreto verrà notificato, in via amministra-  
tiva, a cura della competente Soprintendenza per i Beni  
Artistici e Storici di Bologna al destinatario individuato  
nella relata di notifica e avrà valore nei confronti dei  
successivi proprietari, possessori o detentori a qualsiasi  
titolo.

Avverso il presente decreto è ammessa proposizione  
di ricorso giurisdizionale avanti il Tribunale Amministra-  
tivo Regionale del Lazio, secondo le modalità di cui alla  
legge 6 dicembre 1971, n.1034, ovvero è ammesso ricorso  
straordinario al Capo dello Stato, ai sensi del Decreto del  
Presidente della Repubblica 24 novembre 1971, n.1199,  
rispettivamente entro 60 e 120 giorni dalla data di avvenuta  
notificazione del presente atto.

3 FEB. 1997

Si attesta che la presente fotocopia  
composta da \_\_\_\_\_ fogli è  
conforme \_\_\_\_\_ originale.

IL DIRETTORE GENERALE

DOTT. MARIO SERIO

RB/ns

ROMA





**SOPRINTENDENZA PER I BENI  
ARTISTICI E STORICI  
BOLOGNA**

Pr.: MM/n°1

ISTIAEN

OGGETTO: lancia "ASSUNTA"

Venezia, 18 giugno 1996

Si attesta che la lancia "Assunta" è un' imbarcazione di tipo tradizionale di rilevante valenza storica e particolarmente rappresentativa per la sua tipologia.

Costruita nei cantieri di Cattolica nel lontano 1925 "Assunta", risulta essere la più antica "lancia" romagnola conosciuta e tuttora navigante in Adriatico; lunga 8,50 metri, è larga 2,18 e presenta un puntale di 0,73 m.

L'unicità dell'imbarcazione assume maggior importanza in quanto il suo proprietario, ing. Pier Paolo Marini, ha provveduto ad un accurato restauro nel 1993-94, conservando l'attrezzatura originale con vela al terzo ed utilizzando i materiali dell'epoca. La barca quindi è perfettamente in ordine.

La vela, rigorosamente in cotone, porta i colori ed i simboli che, al momento del suo impiego come barca da pesca, distinguevano la famiglia Garbin (proprietari della barca), secondo l'araldica pescatoria diffusasi nel mare Adriatico.

Non ci risulta la presenza di altre "lance" romagnole costruite prima dell'ultimo conflitto mondiale, né di altre armate secondo la tradizione velica dell'epoca di costruzione.

Nel suo insieme la lancia "Assunta" rappresenta pertanto veramente un "unicum" da proteggere e conservare.

VISTO: IL SOPRINTENDENTE  
Prof. Andrea Emiliani

In fede,

il Vice Presidente  
Mario Marzari

3 FEB. 1996  
IL DIRETTORE GENERALE  
Dott. Mario SENIO

lancia "Assunta"

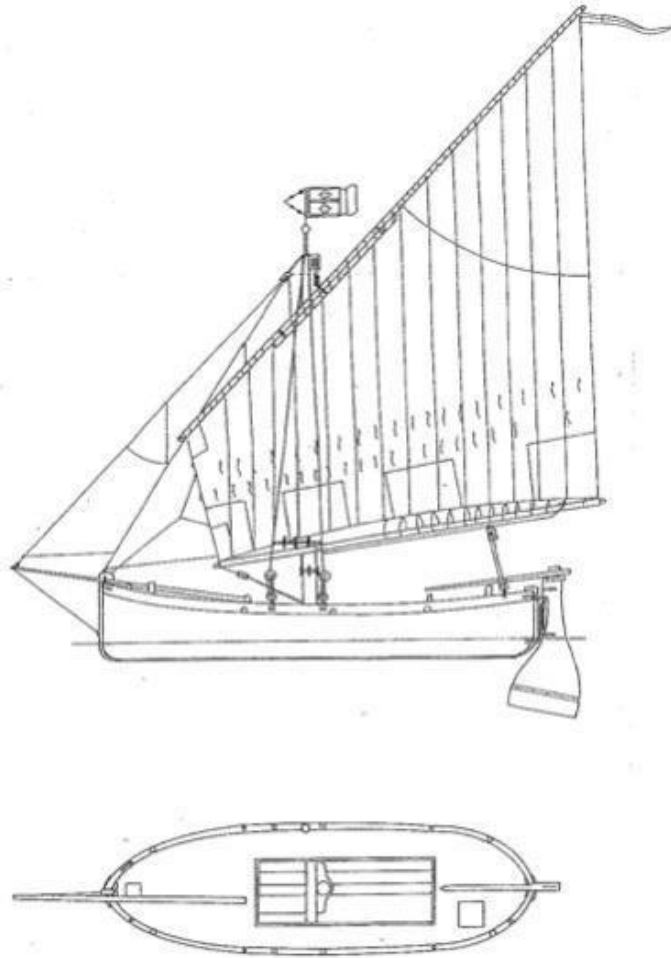

## General vision of the boat



## PP 4 - MUNICIPALITY OF CERVIA

### Cutter Caporale Leone





## Section 1: boat data

<b>Etnographic/ cultural significance</b>	<p>Caporale Leone is a typical beach boat, called cutter, from 1955. The name does not derive from the type of rig (which is rather a sloop or ketch), but from the fact that Romagna fishermen are used to calling every pleasure sailing or motor boat a "cutter", therefore a non-fishing boat could only be a cutter. It is a boat that was very common on the Riviera Romagnola in the years of mass tourism because it was born specifically as a walking boat for swimmers..</p> <p>Traditional boat of Adriatic Sea</p>
<b>Historical significance</b>	<p>Since 15/20 years he has participated in the „Cursa di Batell” regatta which takes place on the occasion of the „Sposalizio del Mare” and for 20 years he has embarked the various characters (writers, artists, actors, journalists, athletes, etc.) who have alternated on the occasion of "Cervia ama il libro” which takes place on August 15th</p>
<b>Technical/nautical significance</b>	<p>Like the other Romagna cutters, the Caporale Leone represents the last traditional sailboat on the Adriatic. Its shapes, the type of sail and some technical solutions (movable centreboat and rudder with tilting blade, sleek lines, Marconi rig ...) derive from the regatta and pleasure boats of the time. She was used to transport tourists for trips offshore or along the coast during the economic boom period</p>
<b>Replica</b>	<p>It is not a replica</p>

### Identification data

**Current boat name**            CAPORALE LEONE

**Current register number  
(if registered)**

**Current harbour/  
location**                    Port of Cervia

**Current owner**

**Contact person/ site**

**Dati sui materiali**

**Boat type/  
Traditional type**            Cutter

**Original function**            Passengers transportation

**Rig**                            marconi

**Lenght**                      Overall length 9,00 m

**Breadth** Overall breadth 2,40 m

**Draught** 1.20 m

**Tonnage or weight**

**Main materials and construction features** Traditional wood building

#### Historical data

**Date/ period of construction** 1955

**Construction place/shipyard or builder** Cantiere di Cola Riziero, Gabicce (PU)

**Designer, if any** Cola Riziero

**Historical presentation** The boat was born in 1955 for the transport of tourists, among the first built specifically for this purpose. The name it was given was "Orsa Maggiore" and the owner was Giulianini Augusto. From 1981 it became property of Modanesi Angelo and took the name of Caporale Leone. Later it underwent various restorations, in 2005 by Giuseppe Zannini and in 2021 by the Cantiere De Cesari.

**Bibliography/ links**

## **Section 2: technical description**

<b>Metric data and shape of the hull</b>	Length 9 m, breadth 2,40 m, height 0,70 m
<b>Structural parts (keel and frames)</b>	Both the ribs and the planking wood were broken, so the boat had to be totally rebuilt.
<b>Planking (external / internal)</b>	Then various treatments of epoxy primers, anti-vegetation and sidewall painting were used.
<b>Deck and openings</b>	Two layers of cross-laminated wood were added to make it stronger as well as two layers of canvas.
<b>Sails and rig</b>	Marconi rig with mainsail and jib painted with the typical ocher colors and with the historic decorative symbol of the sails of the Modanesi family (a crab). Steel rigging and metal mast, running rigging (sheets, halyards, mantle, base struts ...) in modern cordage and equipped with cam jam cleats
<b>Rudder and other</b>	Wooden tiller bar with tilting blade
<b>Other significant elements</b>	Outboard engine 5 HP
<b>Previous restorations</b>	2005 Zannini Giuseppe 2020/21 Cantiere De Cesari

Draft of the plans

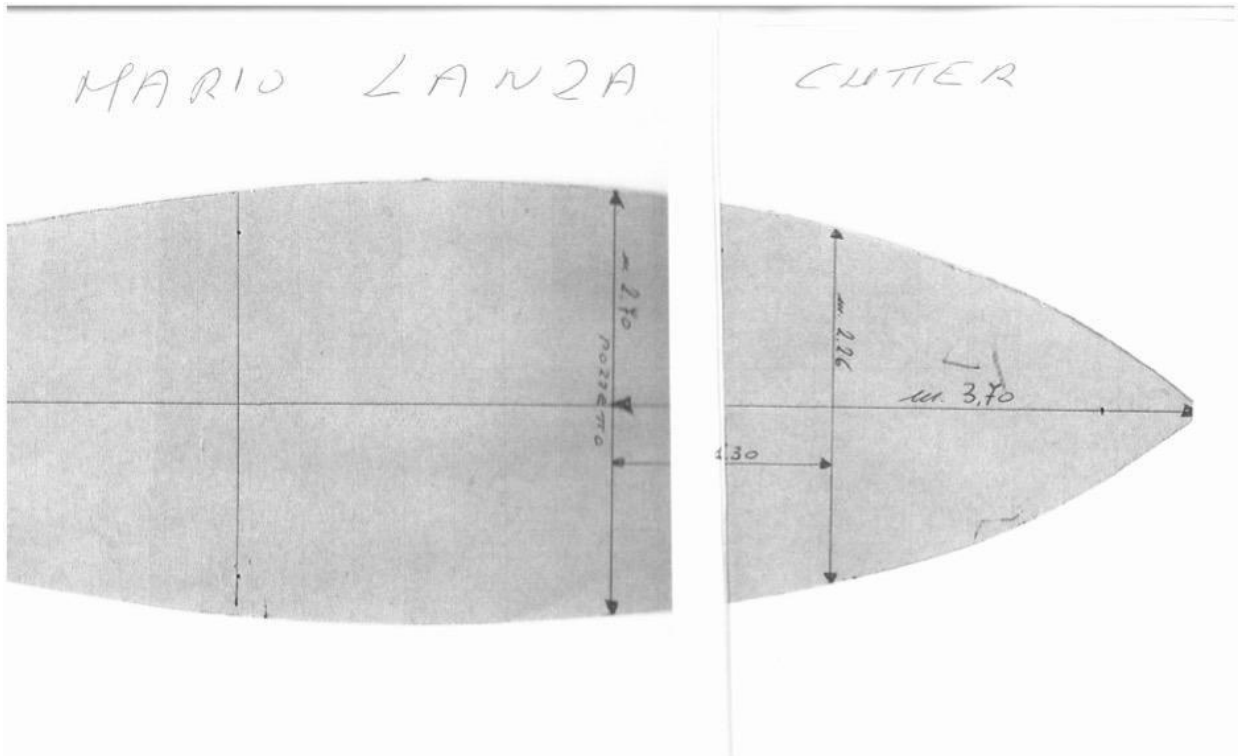

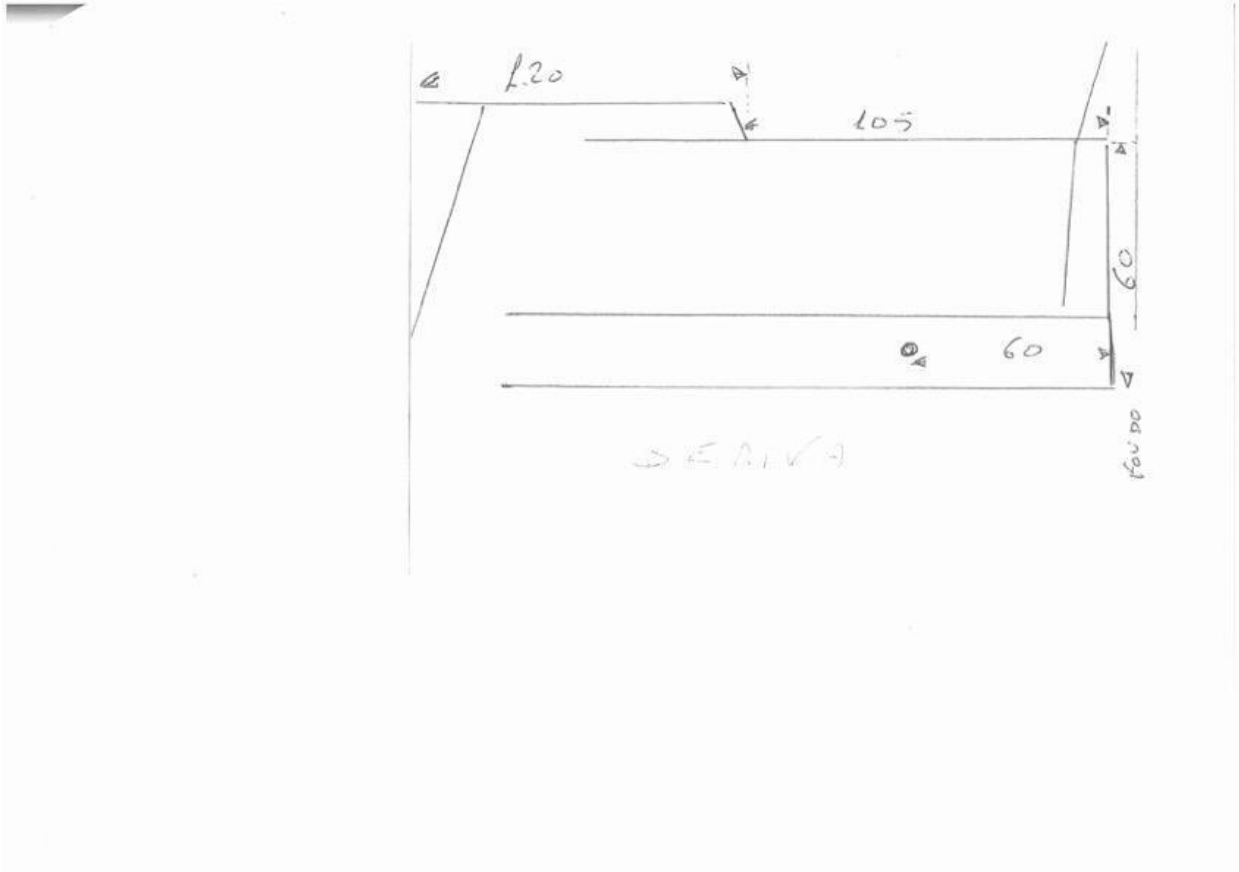

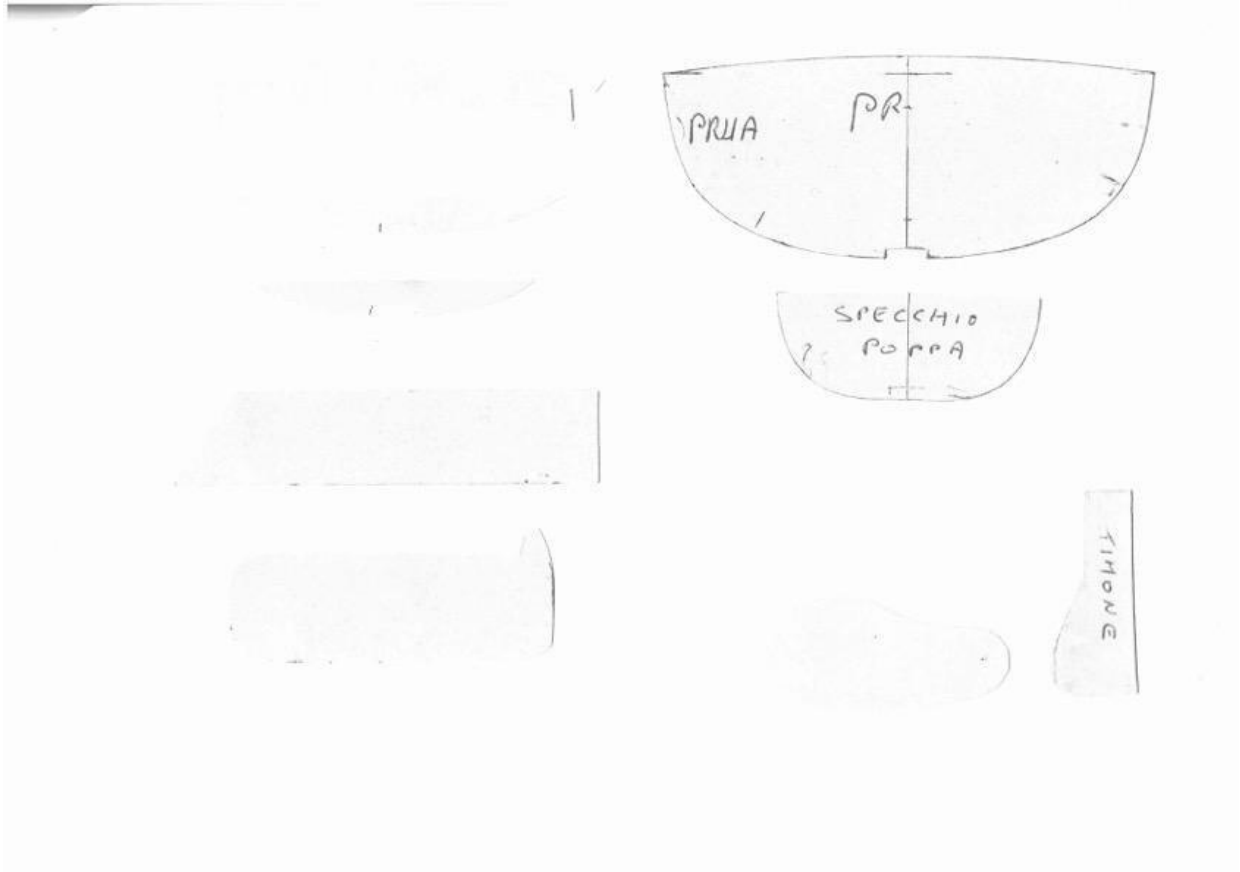

**General view**





## PP 4 - MUNICIPALITY OF CERVIA

### Cutter *Delfino*



## Section 1: boat data

<b>Etnographic/ cultural significance</b>	<p>Delfino is a typical beach boat, called cutter, from 1965. The name does not derive from the type of rig (which is rather a sloop or ketch), but from the fact that Romagna fishermen are used to calling every pleasure sailing or motor boat a "cutter", therefore a non-fishing boat could only be a cutter. It is a boat that was very common on the Riviera Romagnola in the years of mass tourism because it was born specifically as a walking boat for swimmers..</p> <p>Traditional boat of Adriatic Sea</p>
<b>Historical significance</b>	<p>Since 15/20 years he has participated in the „Cursa di Batell” regatta which takes place on the occasion of the „Sposalizio del Mare” and for 20 years he has embarked the various characters (writers, artists, actors, journalists, athletes, etc.) .</p>
<b>Technical/nautical significance</b>	<p>Like the other Romagna cutters, the Delfino represents the last traditional sailboat on the Adriatic. Its shapes, the type of sail and some technical solutions (movable centreboat and rudder with tilting blade, sleek lines, Marconi rig ...) derive from the regatta and pleasure boats of the time. She was used to transport tourists for trips offshore or along the coast during the economic boom period</p>
<b>Replica</b>	<p>It is not a replica</p>

### Identification data

**Current boat name** DELFINO

**Current register number  
(if registered)**

**Current harbour/  
location**

Port of Cervia

**Current owner**

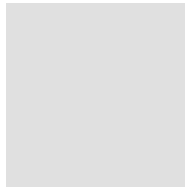

[https://www.turismo.comunecervia.it/it/scopri-il-territorio/itinerari-e-visite/visite-guidate/storia-e-cultura/tour\\_barche\\_storiche](https://www.turismo.comunecervia.it/it/scopri-il-territorio/itinerari-e-visite/visite-guidate/storia-e-cultura/tour_barche_storiche)

**Contact person/ site**

**Materials data**

**Boat type/  
Traditional type**

Cutter

**Original function**

Passengers transportation

**Rig** marconi

**Lenght** Overall length 9,03 m

**Breadth** Overall breadth 2,40 m

**Draught** 1.20 m

**Tonnage or weight**

**Main materials and construction features** Traditional wood building

#### Historical data

**Date/ period of construction** 1969

**Construction place/shipyard or builder** Boschetti Elviro - Cesenatico (EMR - Italy)

**Designer, if any**

**Historical  
presentation**

The boat was born in 1969 for the transport of tourists, among the first built specifically for this purpose. Later it underwent various restorations, in 1997 the hull was fully restored

**Bibliography/ links**

## **Section 2: technical description**

<b>Metric data and shape of the hull</b>	Length 9 m, breadth 2,40 m, height 0,70 m
<b>Structural parts (keel and frames)</b>	The renovation work concerned the deck
<b>Planking (external / internal)</b>	They are assembled in a board where the planks are glued to reach a length of around 9 metres.
<b>Deck and openings</b>	Two layers of cross-laminated wood were added to make it stronger as well as two layers of canvas.
<b>Sails and rig</b>	Marconi rig with mainsail and jib painted with the typical ocher colors. Steel rigging and metal mast, running rigging (sheets, halyards, mantle, base struts ...) in modern cordage and equipped with cam jam cleats
<b>Rudder and other</b>	Wooden tiller bar with tilting blade
<b>Other significant elements</b>	Outboard engine
<b>Previous restorations</b>	1997 Cantiere De Cesari

Draft of the plans

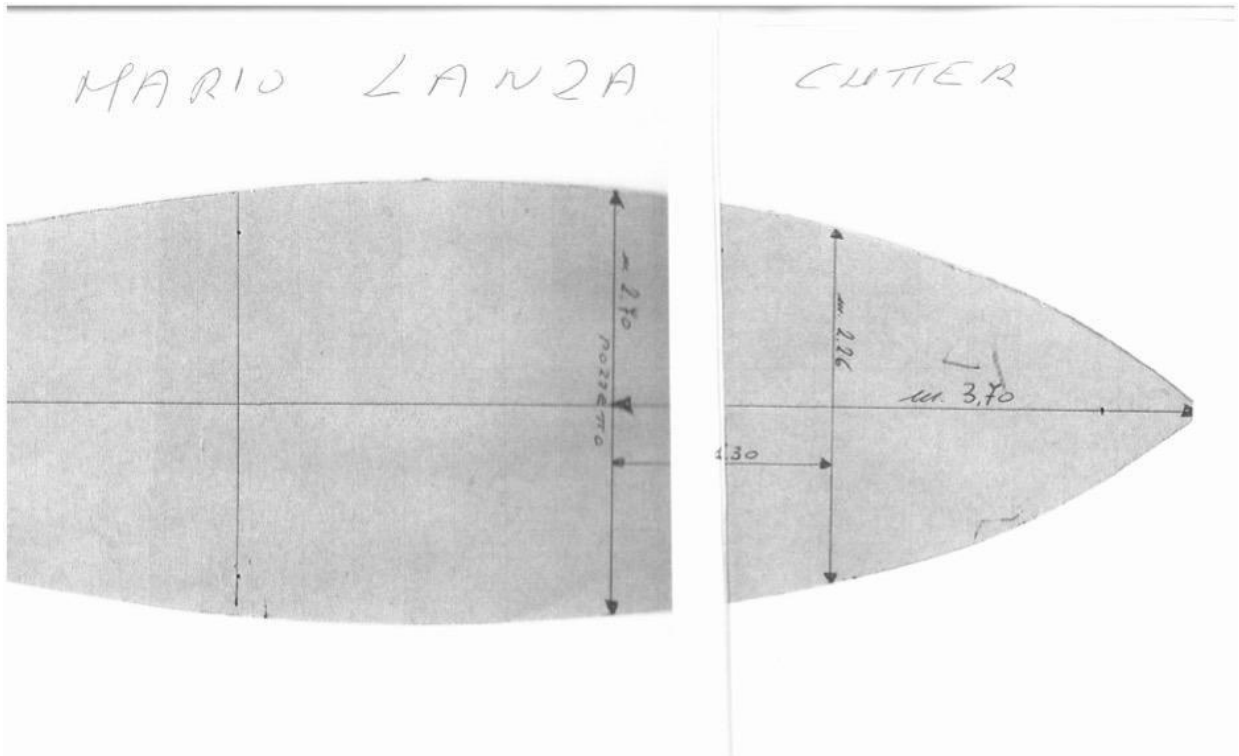

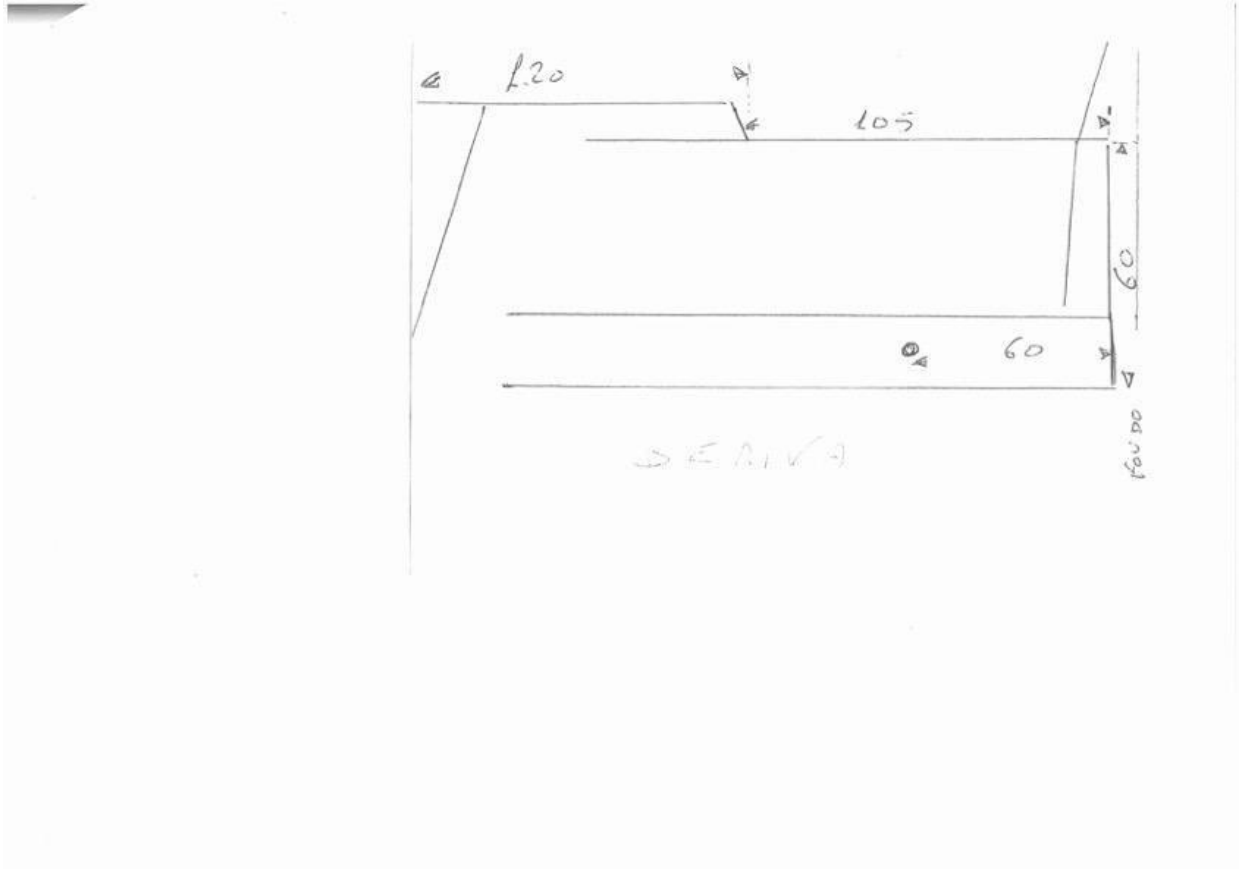



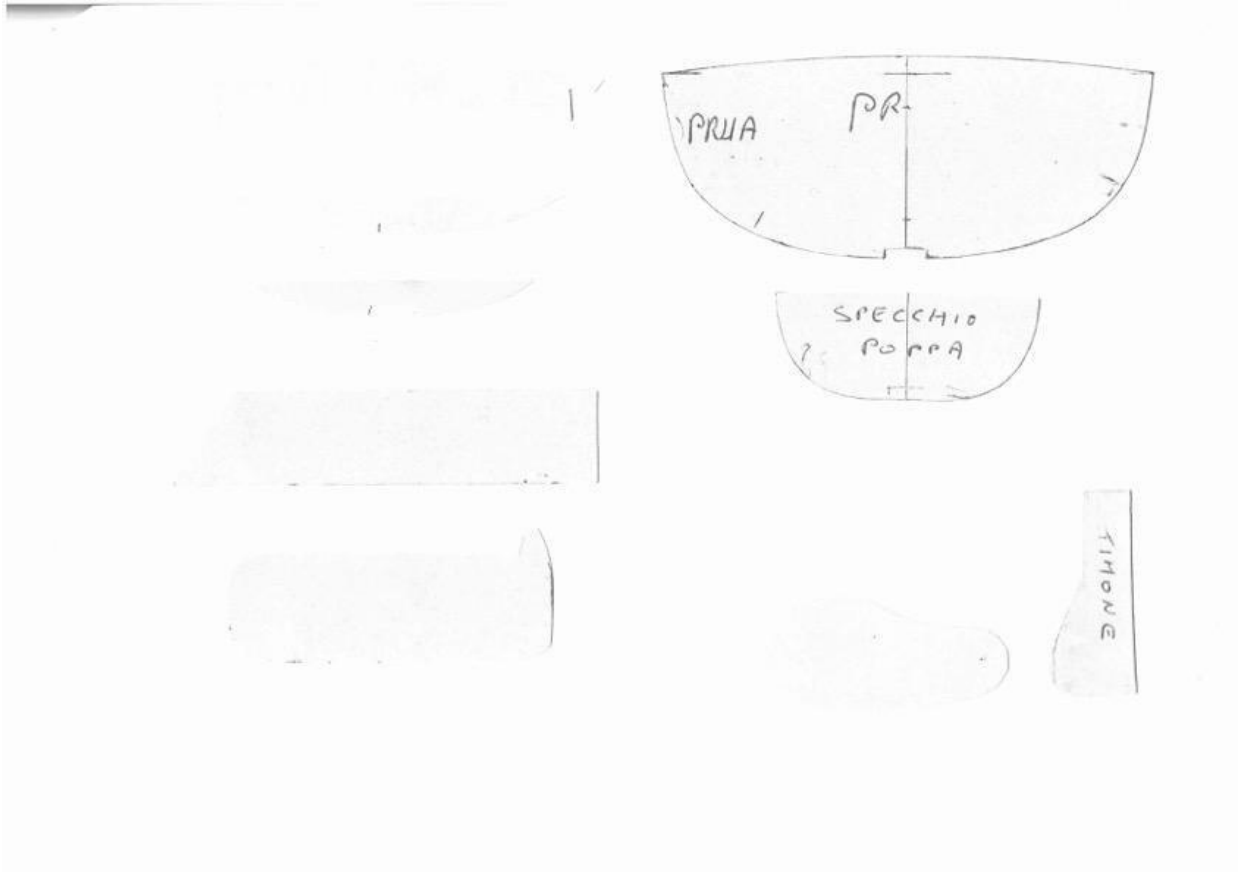

## General view



## PP 4 - MUNICIPALITY OF CERVIA

### Lancia Maria



## **Section 1: boat data**

### **Etnographic/ cultural significance**

The Lancia Maria is a typical 1949 Romagna Lancia, suitable for trawling. The type of propulsion is sailing (at the time of its construction the motorization had not yet spread). The sail is of the so-called "al terzo" type since the upper yard crossed the mast approximately at the upper third of the same. It was used for fishing but many Lancia, in the 50s and 60s were used, in the summer, also as boats for excursions, constituting one of the first examples of integration between fishing and tourism.

### **Historical significance**

The traditional Lancia Maria regularly participates in the rallies and historical events of the Romagna navy such as the "Sposalizio del Mare" in Cervia, the "Garibaldi Festival" in Cesenatico, the "Rotte del Sale" between Romagna and Venice etc. In the so-called "Cursa di Batel" reserved for historic boats held in Cervia on Ascension Day, the Lancia Maria in 2019 ranked first.

### **Technical/nautical significance**

The Lancia Maria has no particular design solutions, but faithfully preserves the original characteristics of the Adriatic lances. The only modification, however common to many boats of the Upper Adriatic era, is the collapsible mast that allows it to pass under the bridges to be moored in the canals and docks of the historic centers.

### **Replica**

No

### Identification data

**Current boat name** MARIA

**Current register number  
(if registered)**

**Current harbour/  
location** Port of Cervia

**Current owner** Associazione culturale Circolo Pescatori "La Pantofla"

**Contact person/  
site**

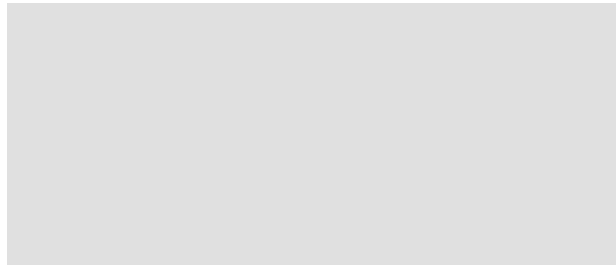

### Material data

**Boat type/  
Traditional type** Lancia Romagnola

**Original function** fishing

**Rig** al terzo

**Lenght** Overall length 8,65 m

**Breadth** Overall breadth 2,57 m

**Draught** Draught 0,70 m

**Tonnage or weight**

**Main materials and construction features** Traditional wood building (oak and larch)

#### Historical data

**Date/ period of construction** 1949

**Construction place/shipyard or builder** Cantiere Berti di Cattolica (RN)

**Designer, if any** Cantiere Berti di Cattolica (RN)

**Historical presentation** The boat launched in 1949 was originally used for fishing, then decommissioned and recovered by Mr. Barberini from Bellaria who restored it for personal use and

also for pleasure. Its traces are lost until the 1990s when it was bought by Mr. Renzo Benini from Cervia and renovated by the shipwright Giuseppe Zannini. In 2001 a Lombardini inboard engine was installed. Following the death of Mr. Benini the boat was donated by the family in 2017 to the cultural association Circolo Pescatori Cervia "La Pantofla". In this phase, the association's volunteers experts in the shipbuilding of traditional boats, under the guidance of the Fioravanti shipyard, a member of the club, carried out a first significant restoration making it navigable. In 2020, highlighting problems with parts of the hull timber, a structural restoration was required as referred to in this announcement and is documented below.

#### **Bibliography/ links**

## **Section 2: technical description**

<b>Metric data and shape of the hull</b>	Length 8.65 m, width 2.57 m, traditional Romagna spear shape
<b>Structural parts (keel and frames)</b>	Structure with frame, keel and frames in oak. Planking and deck in larch
<b>Planking (external / internal)</b>	In larch. Waterproofing with caulking
<b>Deck and openings</b>	Larch deck and two hatches 50 X 50 and 50 X 80 cm
<b>Sails and rig</b>	Sail „al terzo” (mainsail and traditional jib). The decorative elements are those linked to tradition and common to all historical boat sails of that type such as the painted eyes at the bow, the weather vane and above all the sail decorated with the colors and symbols of the Northern Adriatic seafaring.
<b>Rudder and other</b>	Larch rudder and oak bar
<b>Other significant elements</b>	Lombardini inboard engine without structural modifications to the boat
<b>Previous restorations</b>	'90s Giuseppe Zannini



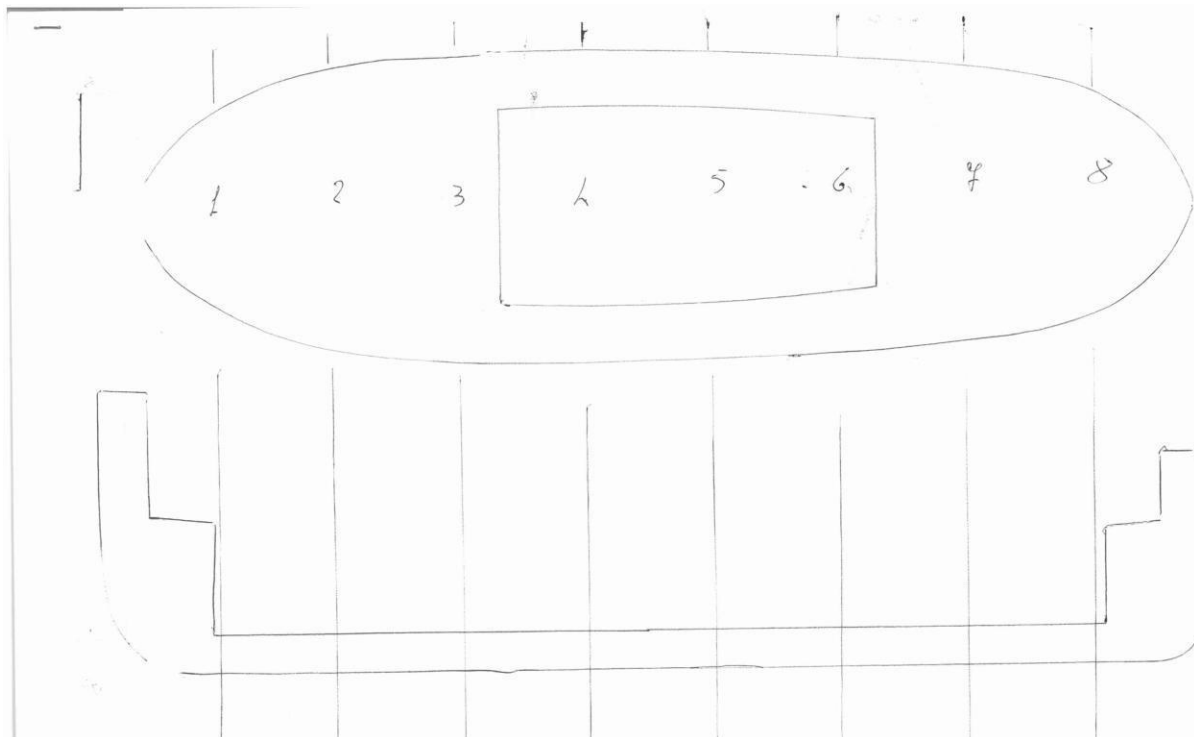

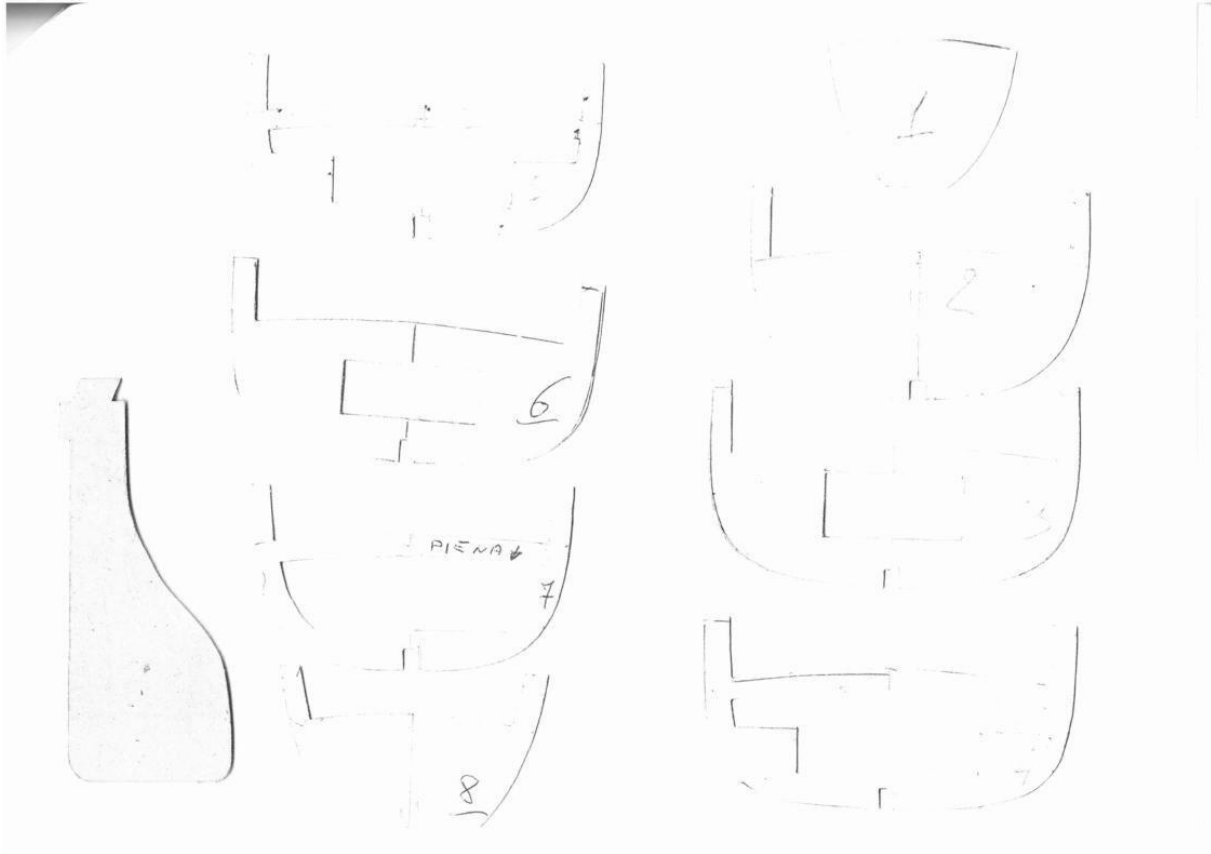

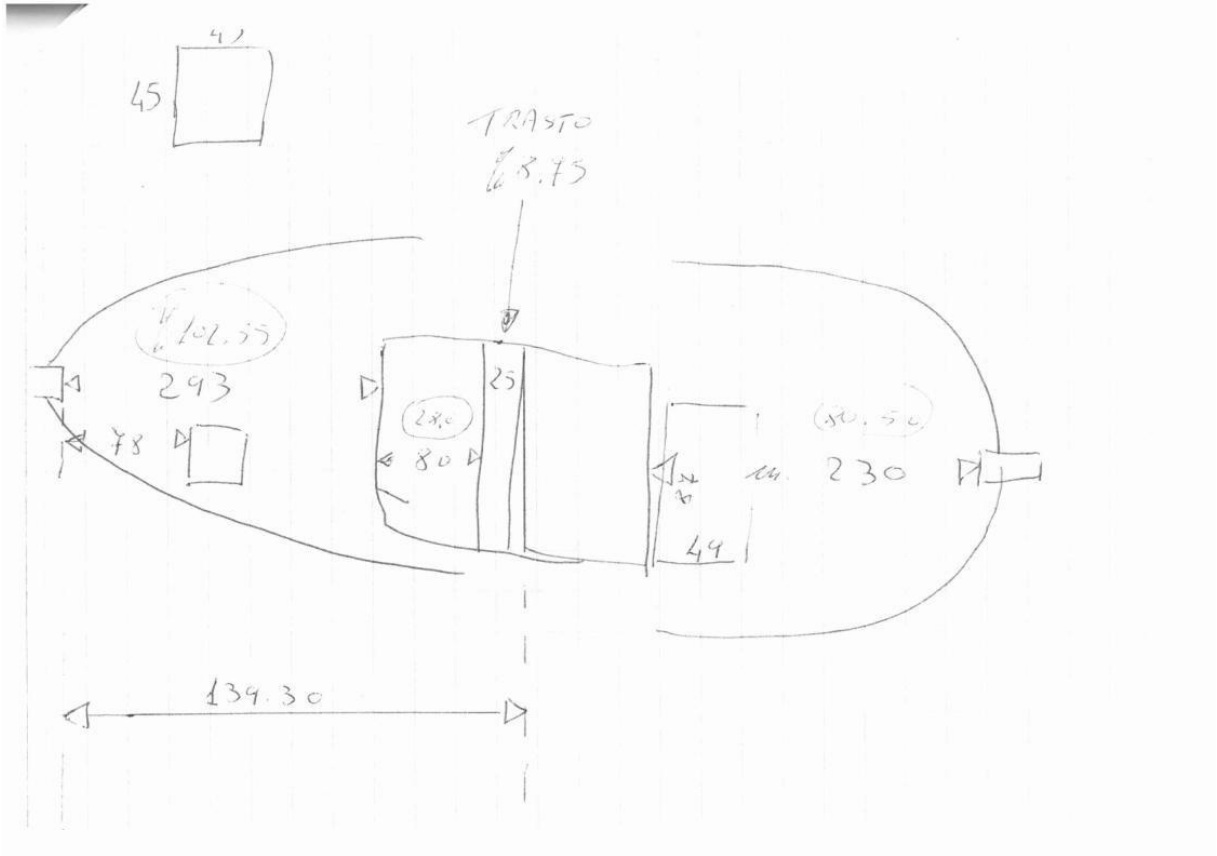

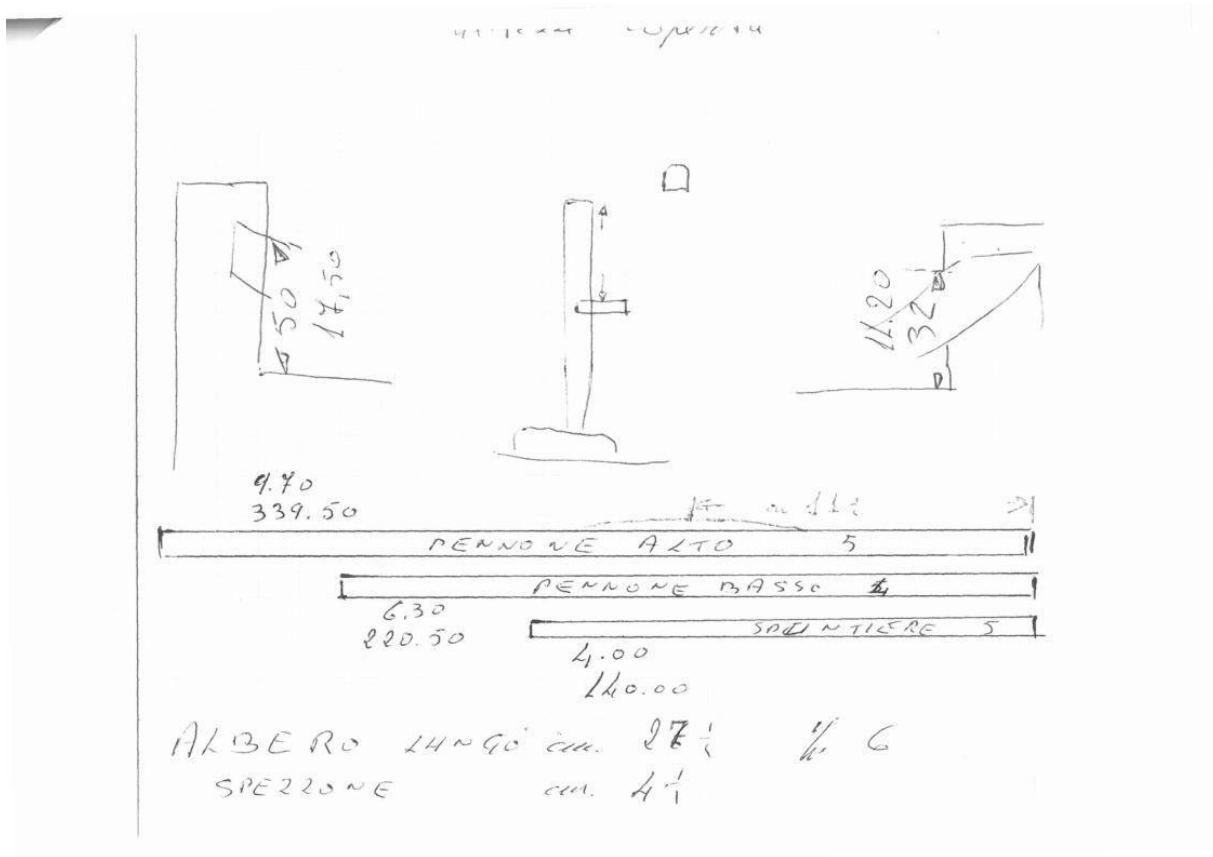

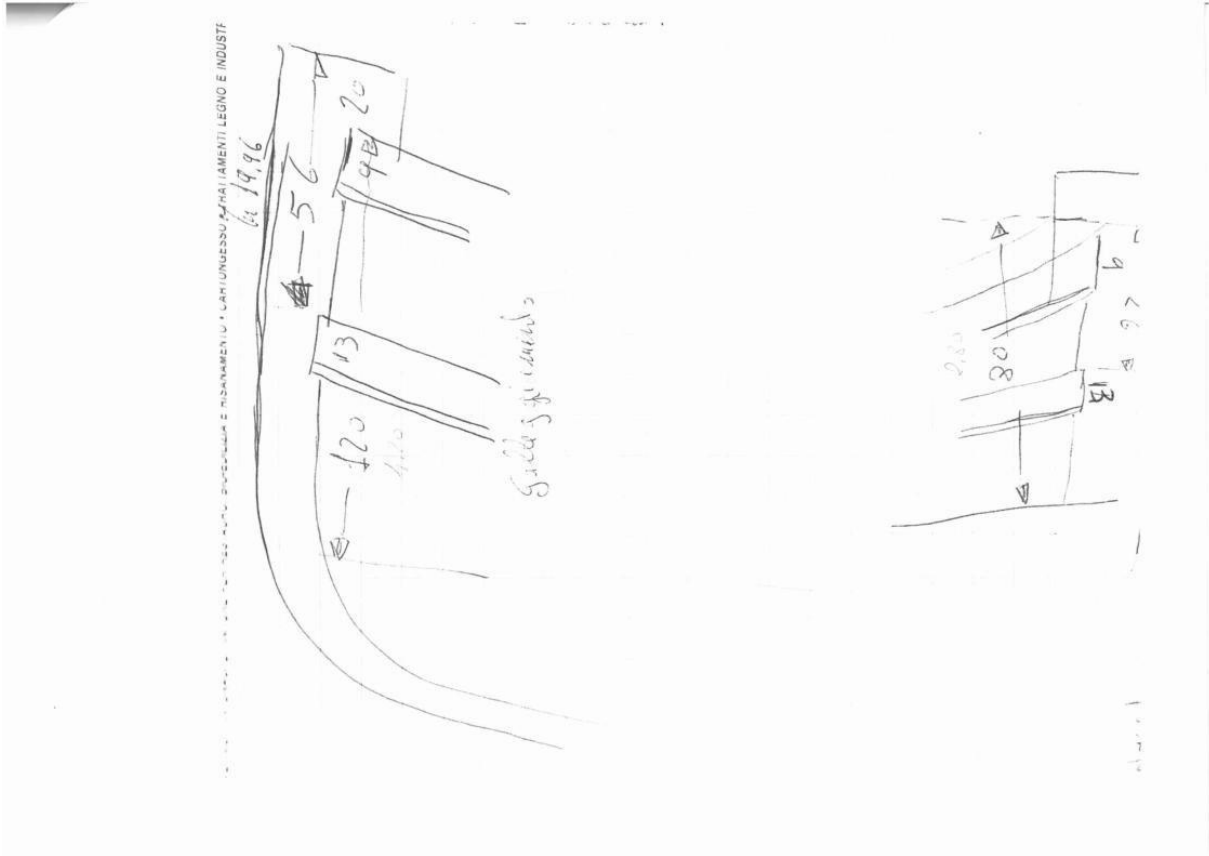

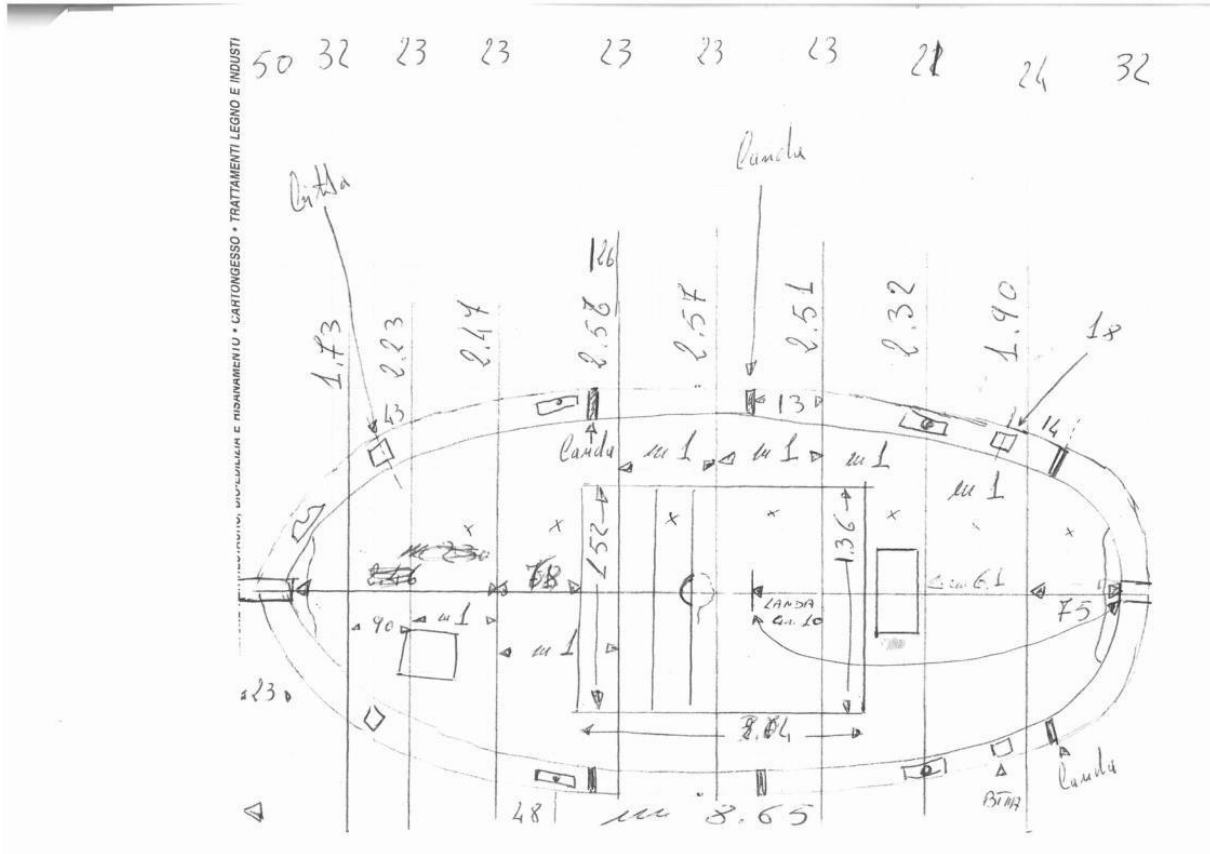







## PP 4 - MUNICIPALITY OF CERVIA

### Lancia Tre Sorelle



## Section 1: dati della barca

**Etnographic/ cultural  
significance**

The boat represents the traditional type of Romagna sailboat used for fishing.  
Traditional boat of the Romagna coast of the Adriatic sea

**Historical significance**

Participation in almost all the gatherings of historic boats organized by the  
various tenze of the Mariegola delle Vele al Terzo and the work boats of the  
Romagna

**Technical/nautical  
significance**

Typical construction of the Cattolica shipyard (Rimini)

**Replica**

No

**Identification data**

**Current boat name**

TRE SORELLE

**Current register  
number  
(if registered)**

RA 4948 D

**Current harbour/  
location**

Cervia (Ravenna) Italia

**Current owner**



Contact person/  
site

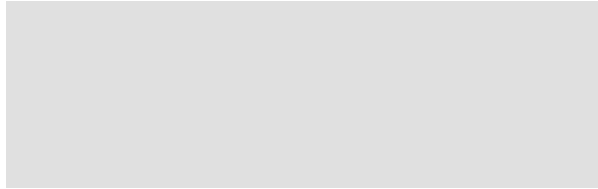

#### Material data

Boat type/  
Traditional type

Lancia romagnola

Original function

Fishing boat

Rig:

“al terzo”

Lenght

Overall length 8,55 m

overall breadth 2,50 m

Breadth/Draught

1,50/0,70 m

Tonnage or weight

kg 3.500

Main materials and  
construction  
features

Traditional wooden building, oak planking

## Historical data

**Date/ period of construction**

1958

**Construction place/shipyard or builder**

Cattolica (Rimini) Italia; shipbuilder Angelo Berti

**Historical presentation**

New construction registered in the Cattolica maritime register in 1958, with the number 690, name Tre Sorelle; length: 8.55 meters; width 2.32 meters; height, at the 0.72m band; 1 cm, a mast with mainsail. Launch 1959. The register indicates that the engine was installed in 1965.

Original use was fishing, motor vessel, 1983 used for pleasure, 1996 intended for traffic "no longer able to be used for fishing". On May 31, 2005 the local Maritime Office of Cattolica ascertained that there had been no news of the boat for a long time and ordered that the "Tre Sorelle" boat, with registration number 3 RM 690, be canceled from the register of minor vessels for "loss alleged ". Two years later the shipwright Alfonso Manzi discovered it abandoned among the car wrecks of a carriage wrecker, in the hills between Riccione and Cattolica. In that period the census of the historical boats of Romagna began, in the card of "Tre sorelle" it was written by hand: "very beautiful", "danger of demolition", "save". In the hands of the Manzi family, Marco Manzi, the son of Alfonso, "Tre Sorelle" was born to a new life, also worked there with competence and passion. It was restored and armed with a third rig, as it was registered for the first time in the directors of the Cattolica Maritime Office.

**Bibliography/ links**

Publications of the Emilia Romagna Region  
Photo on ARCO museum Barcelona magazine  
<https://lanciatresorelle.blogspot.com/>

## **Section 2: technical description**

<b>Metric data and shape of the hull</b>	length: 8.55 meters; width 2.32 meters; height, at the band, 0.72 meters; centimeters. 1, one mast, stern with inserted rudder and overhead tiller.
<b>Structural parts (keel and frames)</b>	Keel, keel, floors, frames, traditional frame
<b>Planking (external / internal)</b>	Oak planking, partly original, waterproofed with saturation through the use of epoxy resins
<b>Deck and openings</b>	No opening for about 2 meters aft and bow, central part for m. 4 open., With open central part; hatch at the bow and at the stern
<b>Sails and rig</b>	“al terzo” rig, a mainsail mq. 46.65, column m 2; with two flagpoles, overpass and underpass; with polaccone (jib) 8 sq m, mobile bowsprit
<b>Rudder and other</b>	Wooden rudder with bar on the head, on needles and wedges, adjustable in immersion.
<b>Other significant elements</b>	Inboard engine
<b>Previous restorations</b>	2007, shipyard Manzi Cattolica, replacement of wooden parts wood saturation work away with epoxy resins;

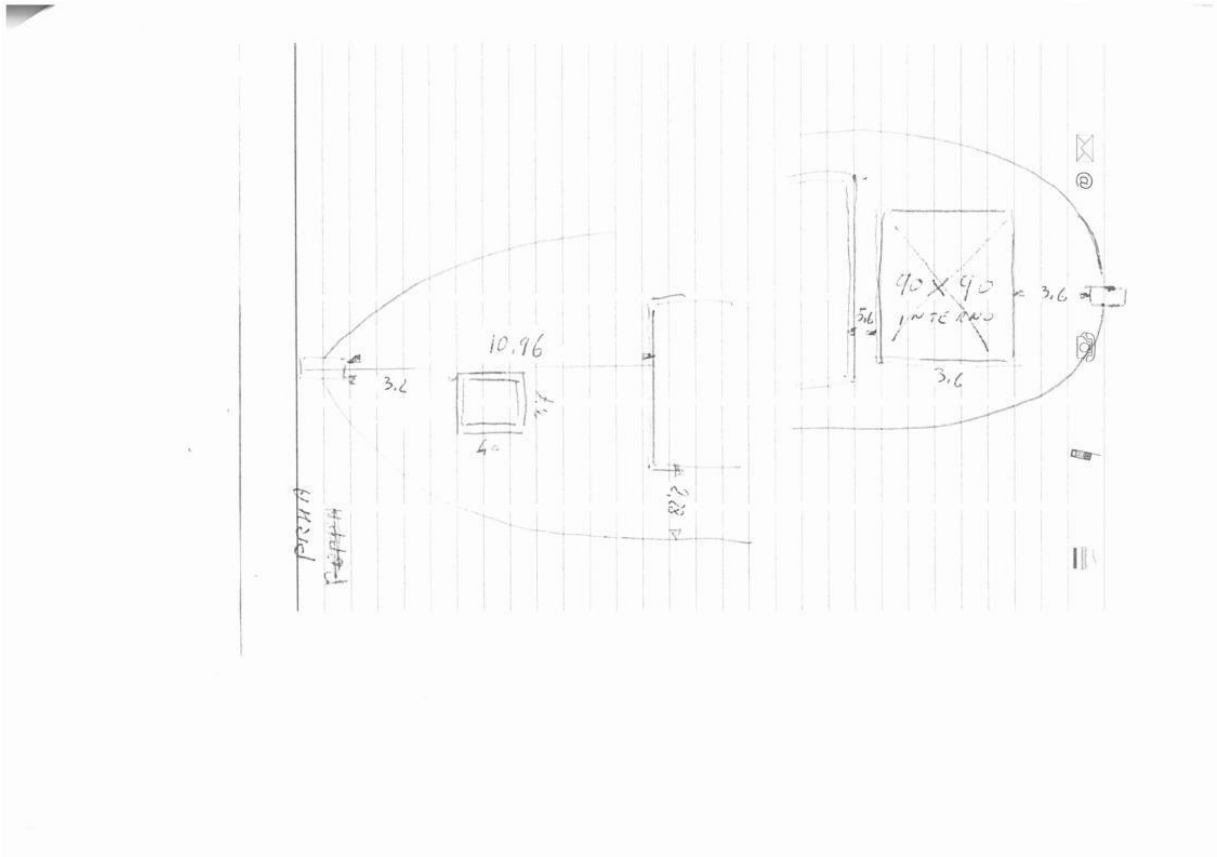

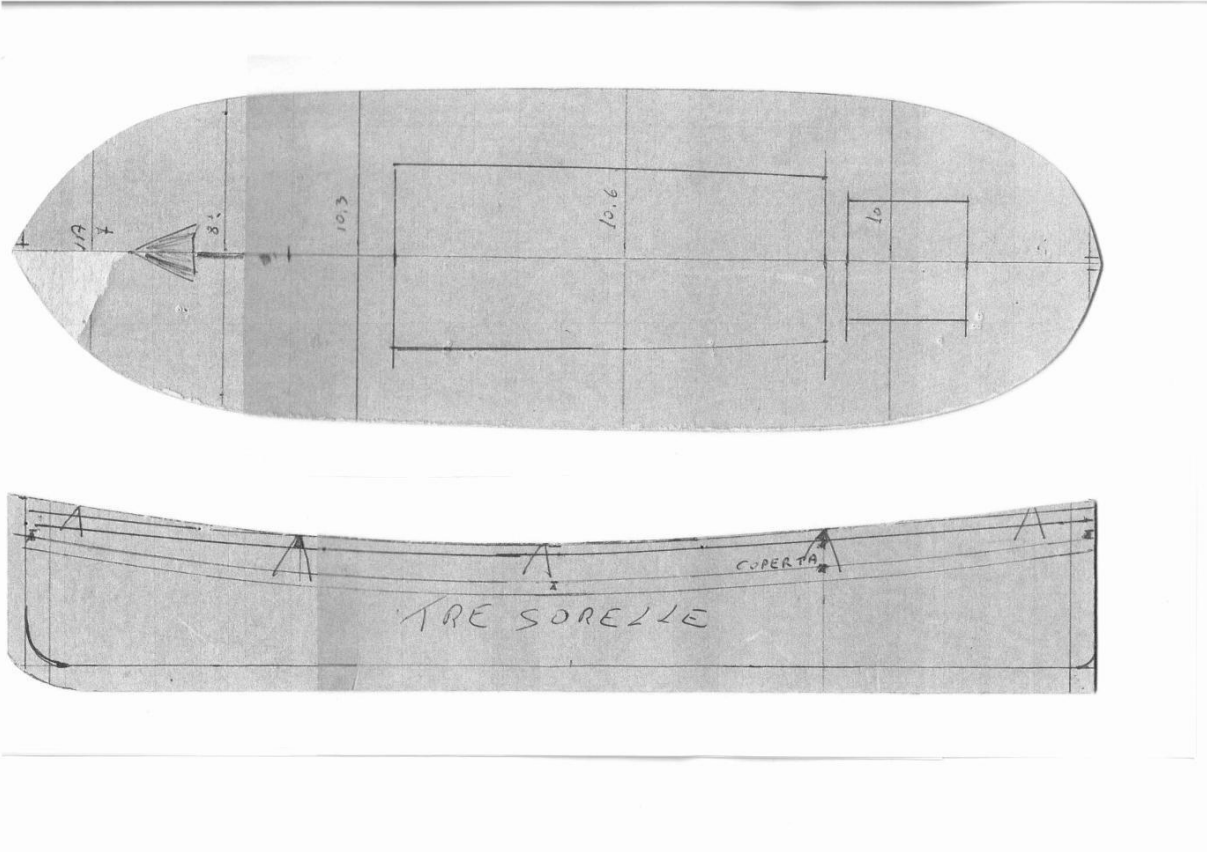

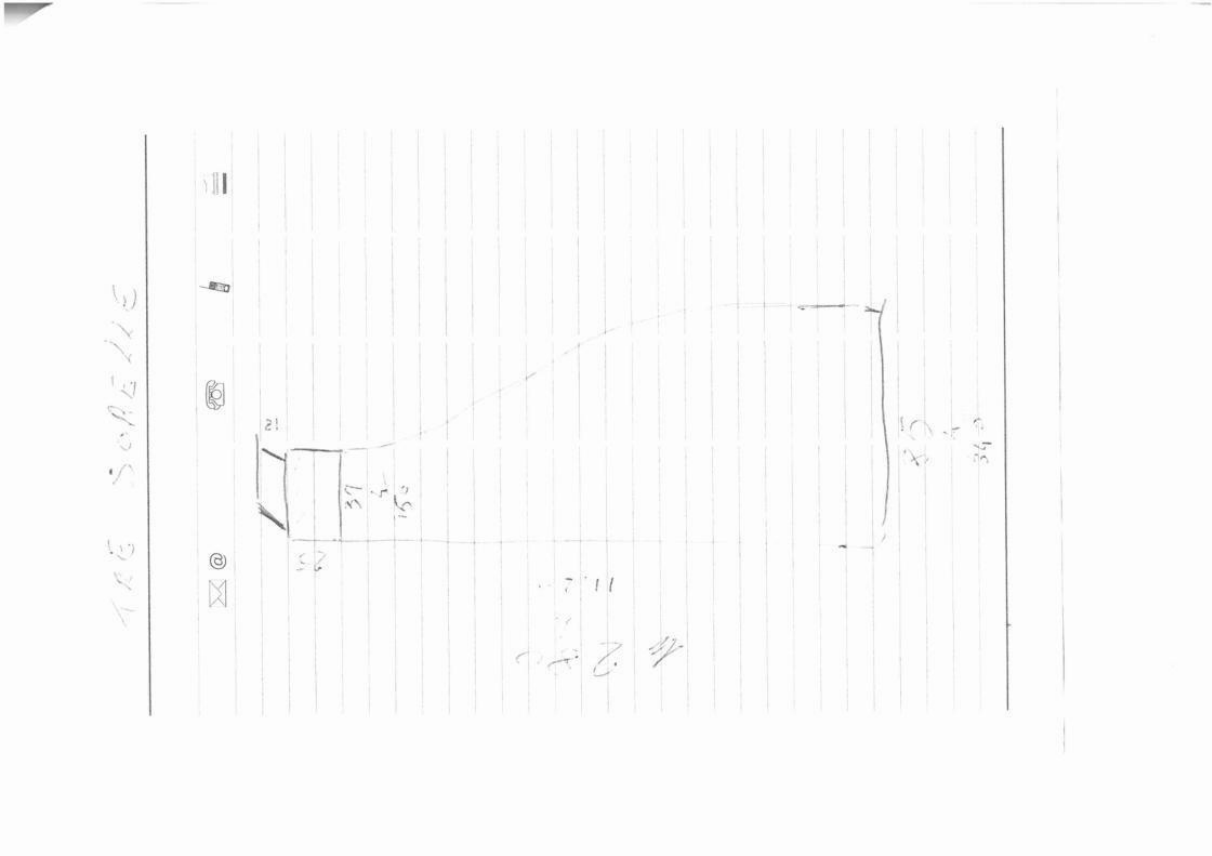



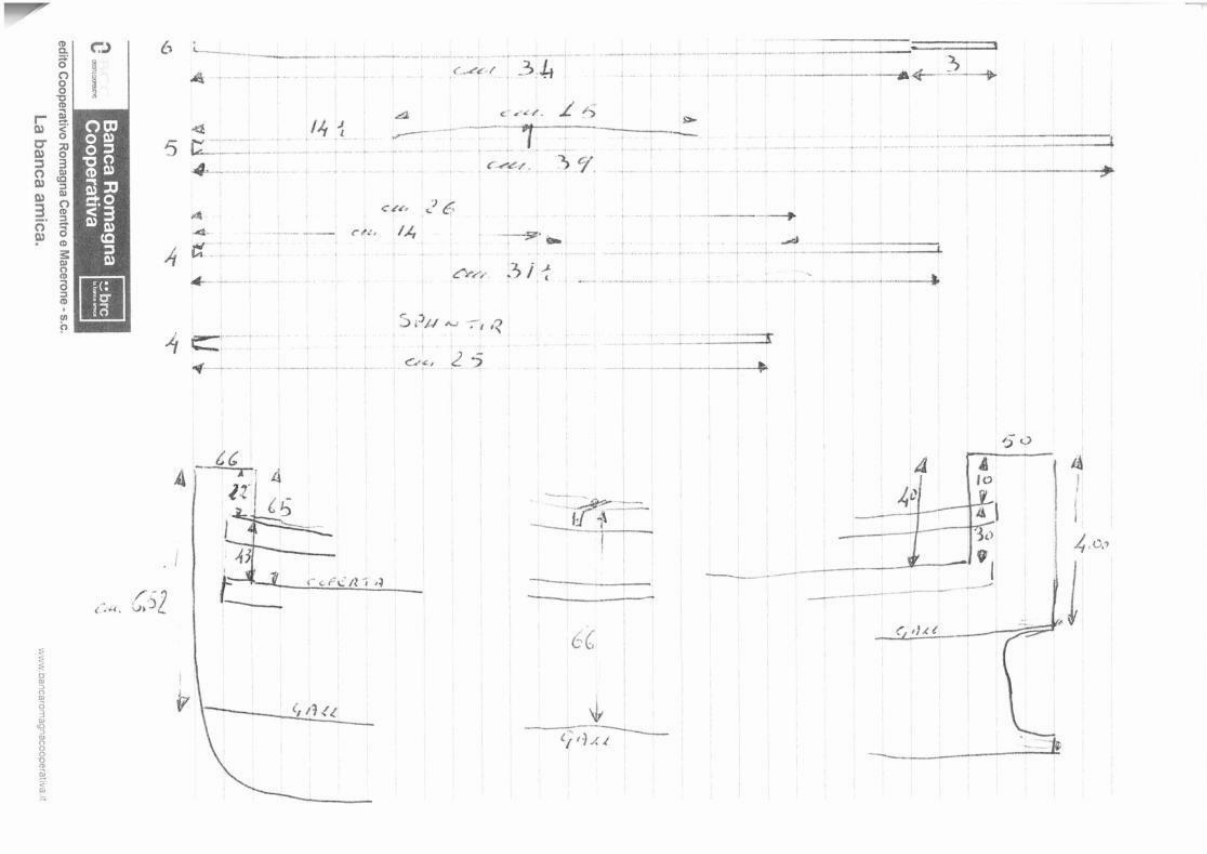

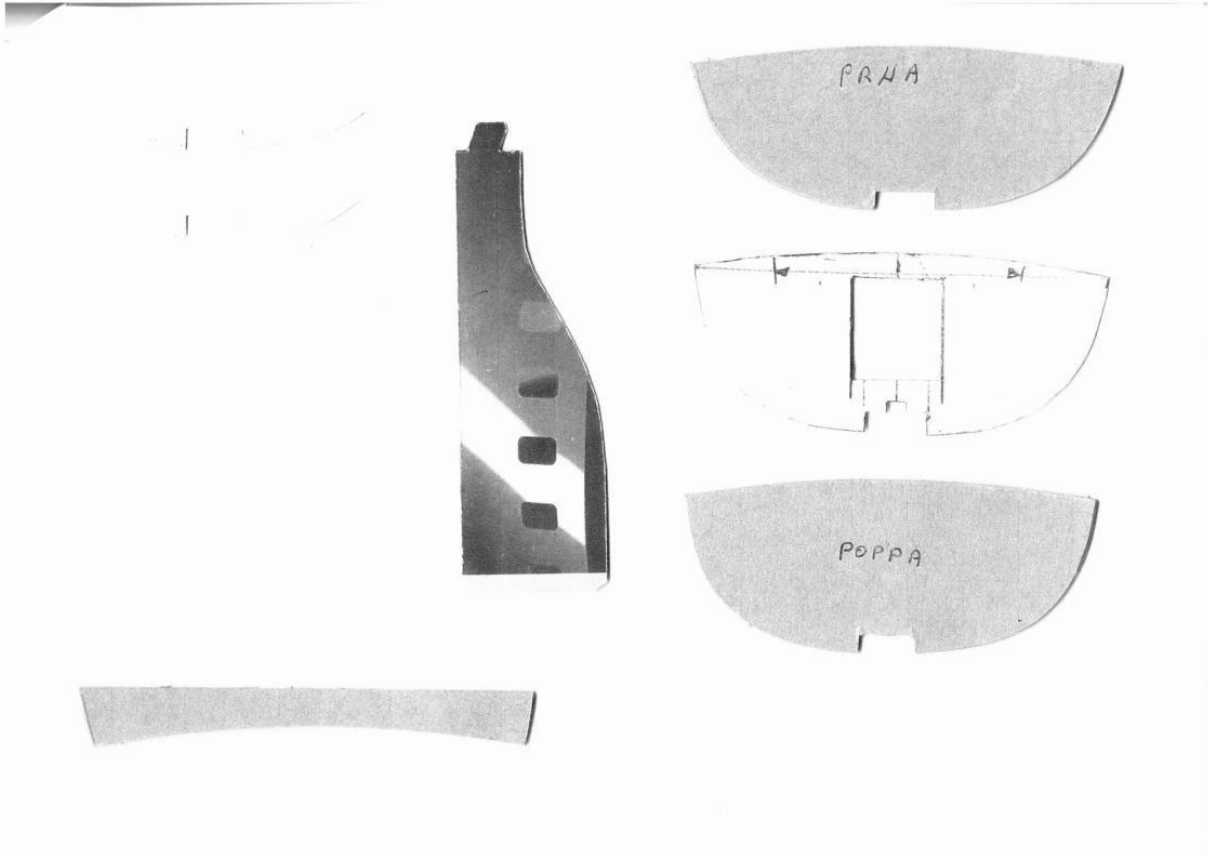

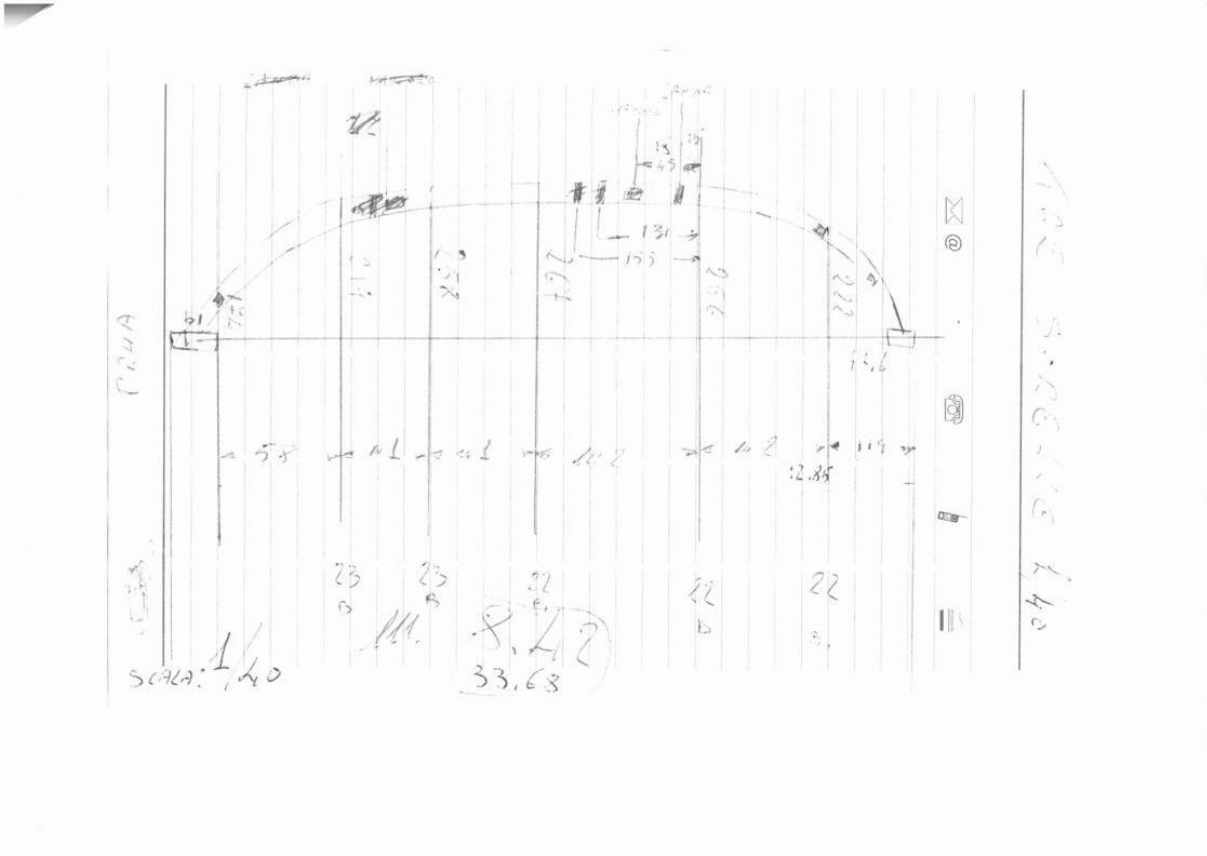

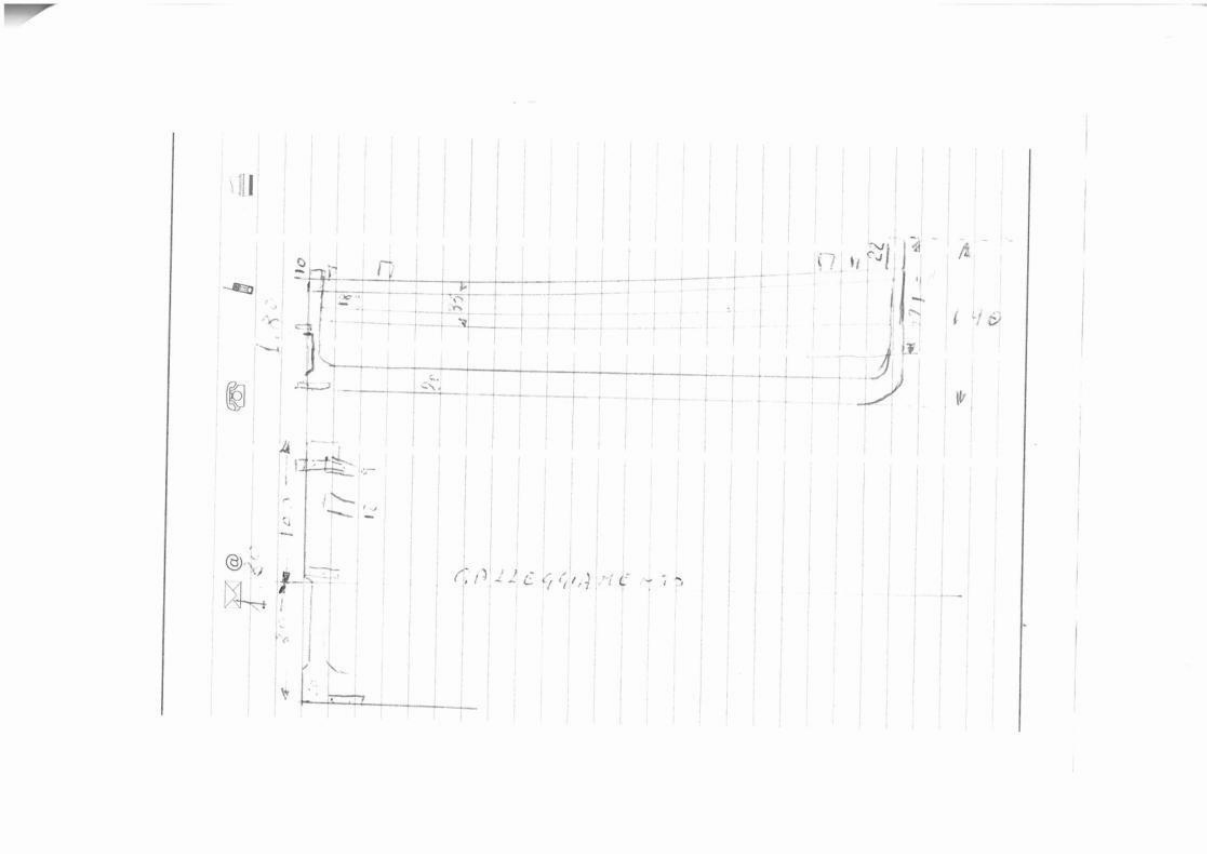



## PP 4 - MUNICIPALITY OF CERVIA

### Lancione *Tre Fratelli*



## **Section 1: dati della barca**

### **Etnographic/ cultural significance**

The boat is typical of the seafaring of the upper Adriatic. It is a two-masted Lancione with sails “al terzo” and two triangular bow sails, built by dr. Riccardo Brizzi in 1966 and used for pleasure boating with berths below deck. It has touched the main ports of both coasts of the northern Adriatic, in 1992 it was donated by Dr. Brizzi to the Municipality of Cervia.

Traditional boat of Adriatic Sea

### **Historical significance**

The boat is moored in the port of Cervia and has participated in all the editions of the „Sposalizio del Mare” at the regatta „Cursa di batell” and above all in all the editions of the „Rotta del Sale”, re-enactment of the route that brought the precious salt from the Cervia salt pans to Venice to whose domain at the time the city of Cervia was subjected.

### **Technical/nautical significance**

The boat has a particular design solution, built on the model of the boats used for fishing that were born with a flat bottom to allow the leeway to the beam for the towing of the nets, during the construction phase it was equipped with a keel that allows the hull a greater maneuverability when sailing abeam and close reach.

### **Replica**

The boat is an exact reproduction of a fishing boat.

### **Identification data**

<b>Current boat name</b>	TRE FRATELLI
<b>Current register number (if registered)</b>	The boat is not registered
<b>Current harbour/ location</b>	Port of Cervia
<b>Current owner</b>	Municipality of Cervia
<b>Contact person/ site</b>	

#### Material data

<b>Boat type/ Traditional type</b>	Lancione romagnolo
<b>Original function</b>	leisure
<b>Rig</b>	Al terzo
<b>Lenght</b>	Overall length 10,40 m
<b>Breadth</b>	Overall breadth 3,10 m



**Draught** Draught 1,20 m

**Tonnage or weight** 7 tons

**Main materials and construction features** Traditional wood building: larch planking, oak keens and frames.

#### Historical data

**Date/ period of construction** 1966

**Construction place/shipyard or builder** Shipyard della Santina, Cattolica.RN

**Designer, if any** Shipbuilder della Santina

**Historical presentation** After the construction which lasted two years, the boat remained moored in the port of Riccione from where the first owner, Dr. Riccardo Brizzi, a neurologist by profession, moved on his cruises in the Adriatic with the whole family. In 1991 the boat was donated to the Municipality of Cervia which carried out the first major restoration by the Cantire Fioravanti of Cervia in 1994. The boat was then used by the Circolo Nautico di Cervia for traditional boat sailing school and various exits. In 2006 the deck was redone by the De Cesari shipyard in Cervia, which was followed, again by the De Cesari shipyard, by other interventions such as the reconstruction of the entire bulwark in 2017, up to the final restoration of the reconstruction and repositioning of the wheelhouse.

**Bibliography/ links** Brochure with drawings and construction details by Mario Alberani.

## **Section 2: technical description**

<b>Metric data and shape of the hull</b>	Length 10.20 m; width 3.10 m; height 3 m. Vertical bow and stern.
<b>Structural parts (keel and frames)</b>	Boat made of planking.
<b>Planking (external / internal)</b>	Larch planking, ordered in oak, original waterproofing with caulking and subsequently restoration with lamellar mahogany cladding carried out by the De Cesari shipyard before the rebuilding of the bulwark in 2017.
<b>Deck and openings</b>	The boat is decked, equipped with an opening for the engine compartment aft of the main mast, opening in the bow of the same for access to the berths, now no longer in use, in the hold there are also two vents for air intakes, aft under the tiller and in the bow alongside the staysail mast.
<b>Sails and rig</b>	Sails „al terzo” rigged with high and low flagpoles on the mainmast and staysail and two triangular traditional jib sails armed on bowsprit, all made of cotton painted with earths.
<b>Rudder and other</b>	Rudder made of laminated wood rebuilt on the original design and steel bar.
<b>Other significant elements</b>	Ford 4-stroke diesel inboard engine.
<b>Previous restorations</b>	1994 shipyard Fioravanti, 2006 shipyard De Cesari, 2017/18 shipyard De Cesari.

## Annexes to the technical description

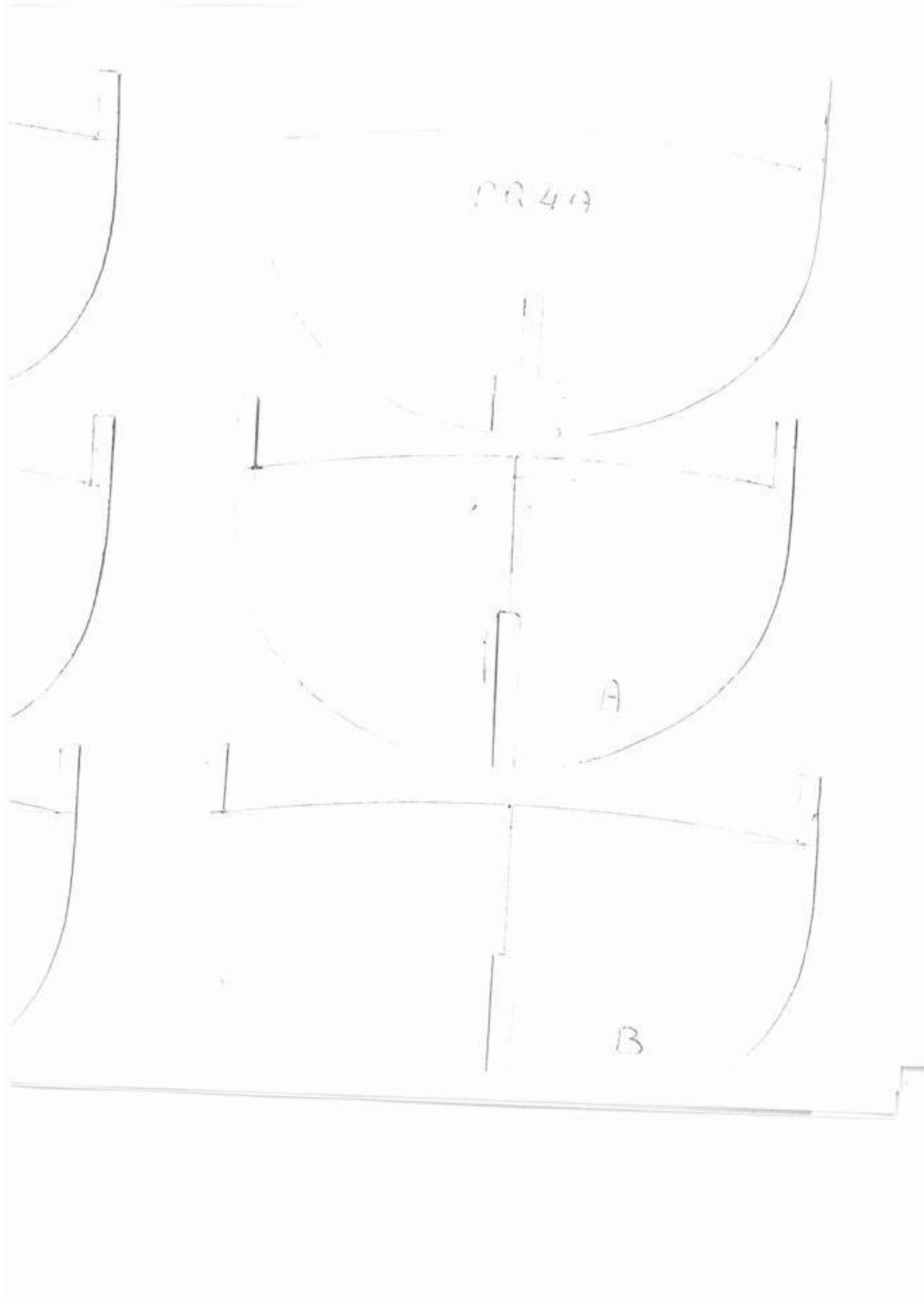

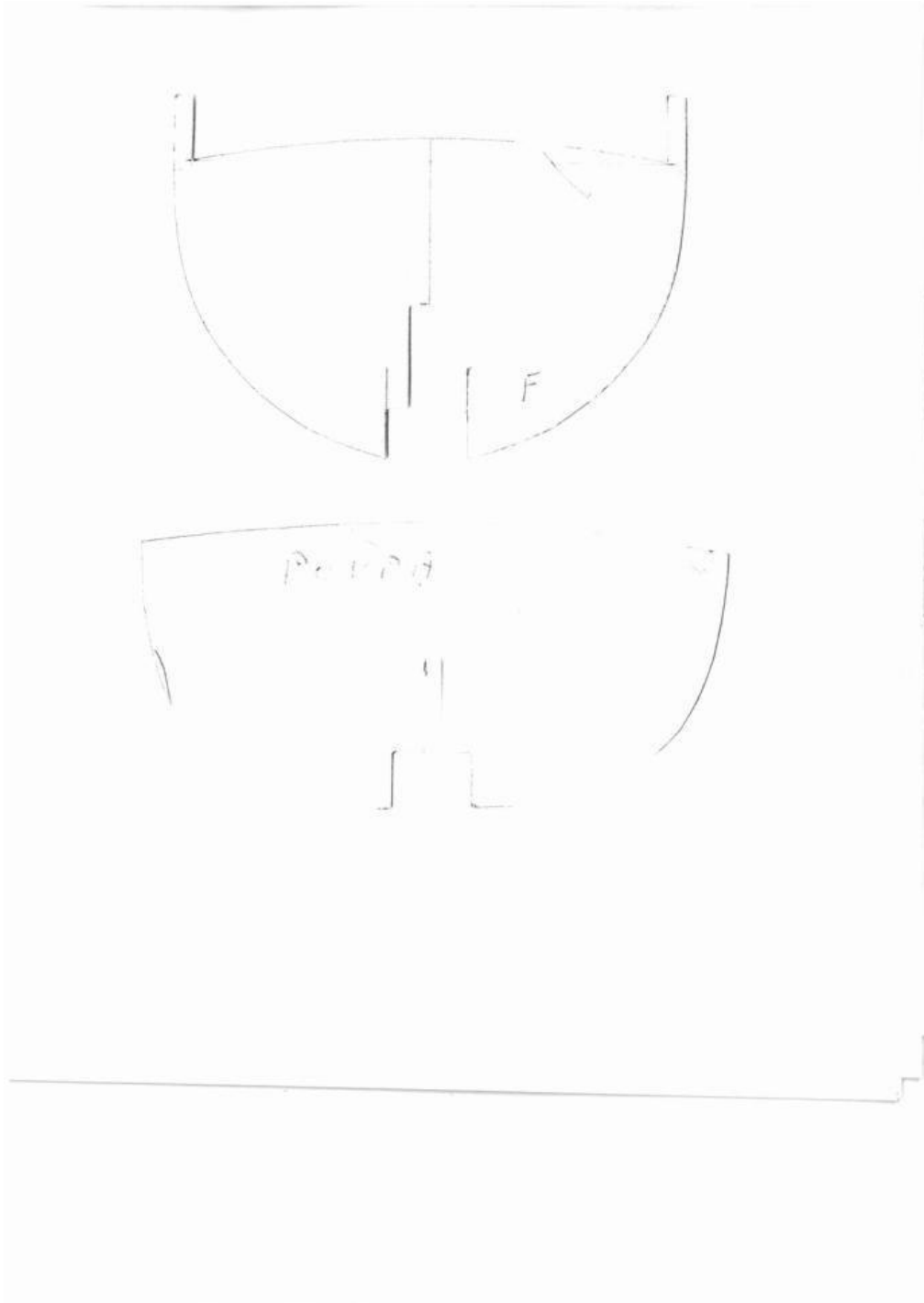

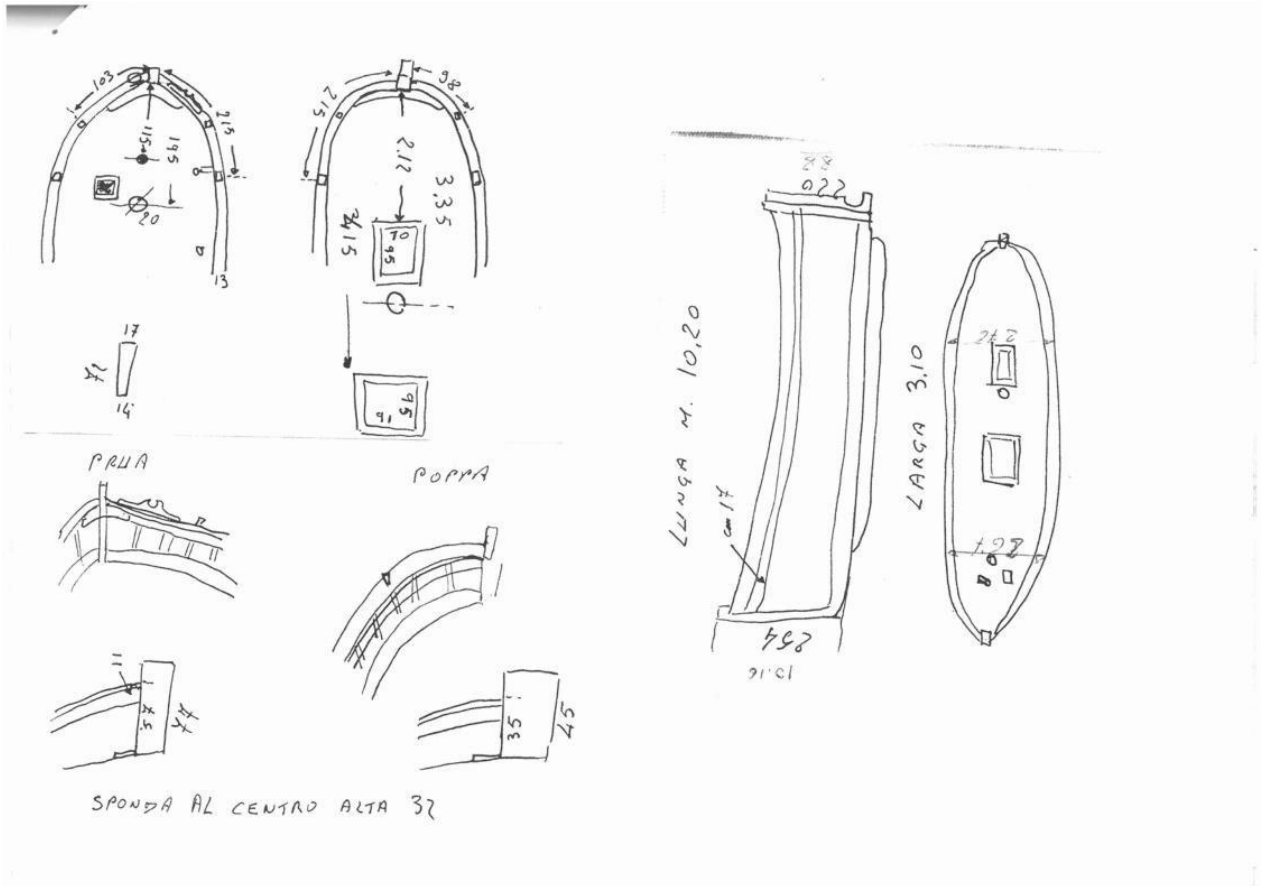

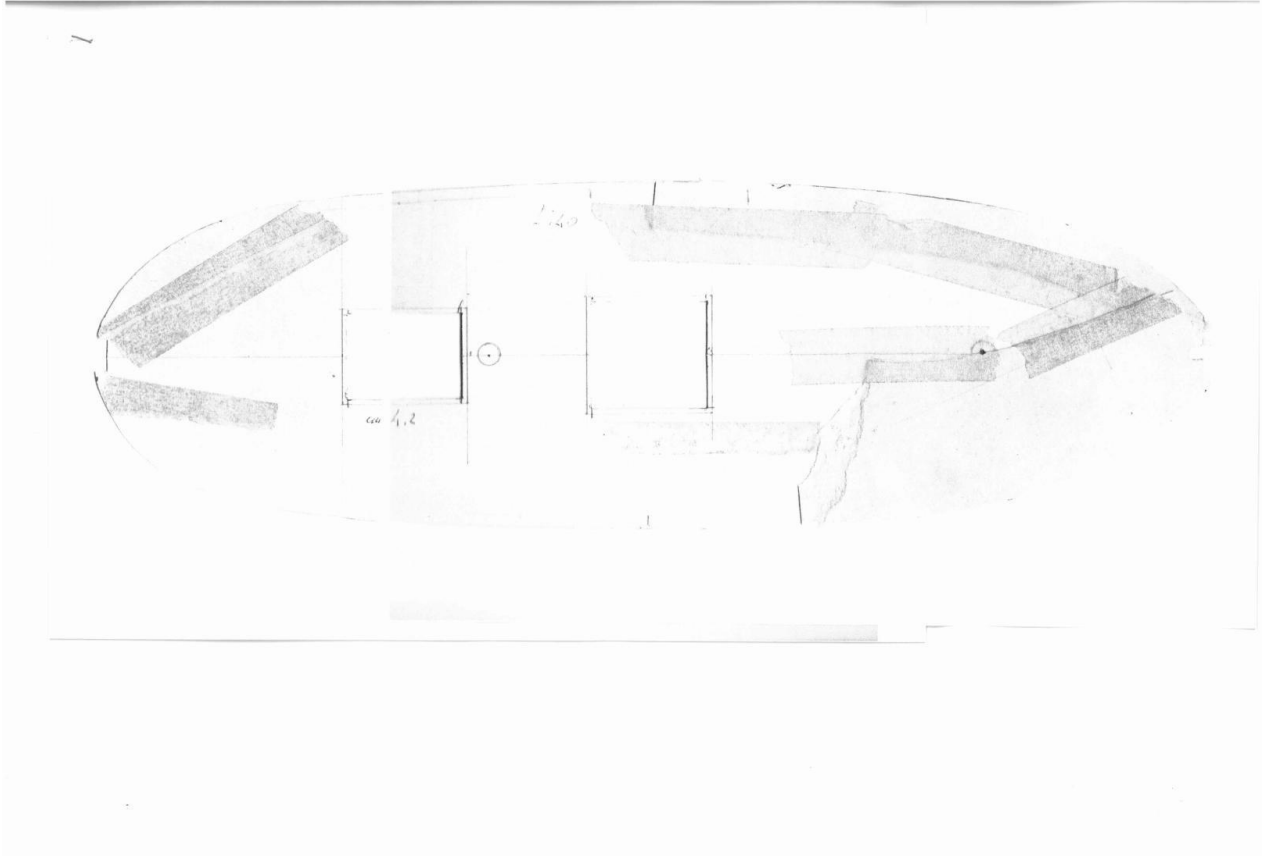



## PP 5 - MUNICIPALITY OF CESENATICO

### Lancia Aldina





## Section 1: boat data

	Motivation for the selection of the boat
<b>Ethnographic / cultural significance</b>	The boat represents the traditional type of the <i>lancia</i> typical of Romagna coast, used for small coastal fishing and related activities
<b>Historical significance</b>	It is one of the boats that have been part of the floating section of the maritime museum of of Cesenatico since the first installation inaugurated in 1983
<b>Technical / nautical significance</b>	
<b>Replica</b>	

	Identification data
<b>Current boat name</b>	Aldina
<b>Current register number (if registered)</b>	
<b>Current harbour / location</b>	Cesenatico, Museo della Marineria, Floating Section ( Cesentiaco harbour)
<b>Current owner</b>	Municipality of Cesenatico
<b>Contact person /</b>	Museo della Marineria – via Armellini, 18 – 47042 Cesenatico FC Italy

<b>site</b>	tel. +39 0547-79205 email <a href="mailto:museomarineria@mune.cesena_tico.fc.it">museomarineria@mune.cesena_tico.fc.it</a> www.museomarineria.it
-------------	---

	<b>Material data</b>
<b>Boat type / Traditional type</b>	<i>Lancia</i>
<b>Original function</b>	Fishing
<b>Rig</b>	“al terzo” sail ( one mast)
<b>Length</b>	7,65 m
<b>Breadth</b>	2,23 m
<b>Draught</b>	0,45 m
<b>Tonnage or weight (if known)</b>	
<b>Main materials and construction features</b>	Traditional construction with wooden planking, hull protected with VTR shell

	<b>Historical data</b>
<b>Date / period of construction</b>	1949
<b>Construction place / shipyard or builder</b>	Cattolica ( RN), shipyard or shipbuilder unknown
<b>Designer, if any</b>	
<b>Historical presentation</b>	After having practiced fishing, the boat was used for a few years for pleasure; in 1979 it was purchased by the Cesenatico Tourist Board, still equipped with sails and fishing equipment, and restored at the Alvaro Farabegoli shipyard in Cesenatico to be placed in the Floating Section of the Maritime Museum inaugurated in 1983.
<b>Bibliography / links</b>	D. Gnola, <i>Il are oltre la spiaggia</i> , Bologna, Regione Emilia-Romagna, 2009, pp. 118-119; Census of traditional boats of the coast of Emilia-Romagna: <a href="http://www.archivimmc.eu/cbr_mostra.php?cercainventario=9">http://www.archivimmc.eu/cbr_mostra.php?cercainventario=9</a>

## Section 2: technical description

<p><b>Metric data and shape of the hull</b></p>	<p>The hull length is 7,65 meters and its width is 2,23 meters. The minimum height measured from the bottom edge of the keel to the deck line is 0.85 m at its lowest part of the deck saddle ( midway between seticon lines 2 and 3), and fore and aft, where a due to the shape of the hull, the deck line is slightly higher, the hull height is measured respectively at 1,34 m and 1,19 m.</p>
<p><b>Structural parts (keel and frames)</b></p>	<p>The keel is thick 10 cm and height 12 cm, measured by the relief and the shape of the hull's stellature. Continuing the keel there are rods that maintain the same thickness of the keel of 10 cm and reach the maximum height in a single wooden element. The ordinates are in total 34. The frames have an average thickness of 4-5 cm and a height of 6-8 cm and spaced to create a bilge space of 19 cm.</p>
<p><b>Planking (external / internal)</b></p>	<p>The external planking is represented by boards of varying widths placed side by side and nailed to the frames from the outside according to the classic traditional construction of spears and Adriatic boats. The longitudinal connection of the frames, in order to stiffen and reinforce the structure, is represented by three different longitudinal tables, called <i>serrette</i>.</p>
<p><b>Deck and openings</b></p>	<p>The bridge is made up of 16 longitudinal iroko wood boards, on average 0.12 m wide; these do not represent the original ones of the hull but have been replaced in a previous phase of restoration, choosing this wood for its hardness and durability. The two at the port and starboard ends run throughout the hull and are in fact divided into two boards to be able to cover the entire length. The central ones are naturally shorter due to the central opening of the hold. The deck has a single large opening approximately in the center of the hull and has regular rectangular dimensions of 3,08 x 1,44; starts at 2,03 m from the stern rod, at the ordinate 10 and ends at the bow at 5.10 m, at the ordinate 23. On each of the two sides, two scuppers were made at the height of the bridge, in the lower part of the saddle, in order to let the water flow from the main deck. The main deck has, along its entire length, a continuous high edge, a longitudinal protection element, usually called the gunwale, which has the function of protecting the entrance of the waves, raising the side and above all to increase the safety of the crew and the accidental leakage of nets or material placed on deck with the inclination of the boat.</p>

	The <i>ancoli</i> ( cleats) tick out from the gang leader, a pair at the stern, two pairs in the bow.
<b>Sails and rig</b>	At the center of the boat, the 76 x 26 x 7 cm thick mast box is nailed to the 4 central frames ( from 16 to 19) and has a square hole for the foot of the mast of 8.5 cm sideways. Corresponding to the box is the slightly curved side ( 27 x 4 cm), with a hole for the mast, not central but moved towards the stern side to create a semicircular recess on the side. The sail rig is one “al terzo” mainsail and one foresail rigged on a bowsprit.
<b>Rudder and other steering elements</b>	The rudder is 2 meters high and 1 wide and its large dimensions are those characteristic of Adriatic boats. The irons for attaching to the stern rod are composed of a male at the top and a female at the bottom.
<b>Other significant elements</b>	
<b>Previous restorations</b>	The boat was restored at first in the early '80s by the shipyard of Alvaro Farabegoli ( Cesenatico) who made the work for all the boats for the first Floating Section of the maritime museum of Cesenatico: the purpose was to restore the original typology of the boat; later, the boat underwent routine maintenance and also a previous deck reconstruction.

## Annexes to the technical description

Insert a reduced plan of the boat in the frame below



Insert a photo with a general view of the boat in the frame below

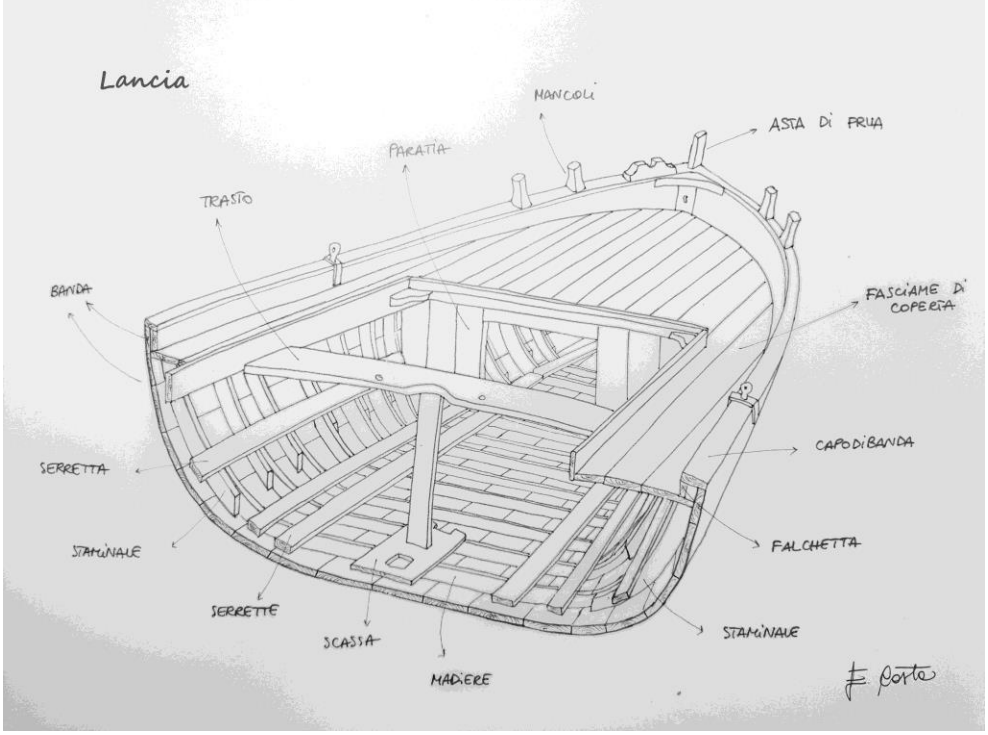

	
<p>Documentation about the history of the boat <i>*if available</i></p>	

<p><b>Name of the compiler</b></p>	<p>Elisa Costa ( external expert) Davide Gnola ( museum director / conservator)</p>
<p><b>Date of compilation</b></p>	<p>30/9/2021</p>



Photos





## PP 5 - MUNICIPALITY OF CESENATICO

### **Bragozzo San Marco**



## Section 1: boat data

	Motivation for the selection of the boat
<b>Ethnographic / cultural significance</b>	The boat represent the traditional type of the <i>bragozzo</i> , very important and typical of Chioggia and the Venice lagoon, but also spread in the coast of Romagna and northern Adriatic sea. The <i>bragozzo</i> was also the boat used by the families of fishermen who moved from Chioggia to the ports of Romagna in the 19th century and so it is an important heritage of this social exchange.
<b>Historical significance</b>	The <i>bragozzi</i> were used by Giuseppe Garibaldi in the historical episode of the boarding in Cesenatico on 2 August 1849, in an attempt to reach Venice.
<b>Technical / nautical significance</b>	
<b>Replica</b>	

	Identification data
<b>Current boat name</b>	San Marco
<b>Current register number ( if registered)</b>	

<b>Current harbour / location</b>	Cesenatico, Museo della Marineria, floating section ( harbour of Cesenatico)
<b>Current owner</b>	Municipality of Cesenatico
<b>Contact person / site</b>	Museo della Marineria – via Armellini, 18 – 47042 Cesenatico FC Italy tel. +39 0547-79205 email <a href="mailto:museomarineria@mune.cesenatico.fc.it">museomarineria@mune.cesenatico.fc.it</a> <a href="http://www.museomarineria.it">www.museomarineria.it</a>

	<b>Material data</b>
<b>Boat type / Traditional type</b>	bragozzo
<b>Original function</b>	fishing
<b>Rig</b>	“al terzo” sail ( two mast)
<b>Length</b>	13,88 m
<b>Breadth</b>	3,65 m
<b>Draught</b>	1 m
<b>Tonnage or weight ( if known)</b>	

<b>Main materials and construction features</b>	Traditional construction with wooden planking, hull protected with VTR shell
---	--

	<b>Historical data</b>
<b>Date / period of construction</b>	1956 ( see below)
<b>Construction place / shipyard or builder</b>	Chioggia, Domenico Ranzato
<b>Designer, if any</b>	
<b>Historical presentation</b>	<p>The documentation in the archive of the Maritime Museum of Cesenatico indicates the Domenico Ranzato shipyard in Chioggia as the builder and 1956 as the construction date, but the analysis of the hull made in the first restoration suggest that the date of 1956 maybe refers to the recovery of the hull after a period of long abandonment, and that its origin must go back to a much more distant period, as the beginning of the 20. century or the end of the 19. century. The seaworthiness certificate issued by the Port Authority of Venice on 12/4/1978 authorized it to transport passengers within 1 mile from the coast. Purchased in 1983 by the Cesenatico Tourist Board from Renzo Cappato, owner of a passenger transport company in the Venetian lagoon, it was transported by land in 1983 from Marghera to Cesenatico, and then restored in order to be placed as representative of a large <i>bragozzo</i> boat in the floating section of the museum inaugurated in 1983.</p>
<b>Bibliography / links</b>	<p>D. Gnola, <i>Il are oltre la spiaggia</i> , Bologna, Regione Emilia-Romagna, 2009, pp. 112-113;</p> <p>Census of traditional boats in the coast of Emilia-Romagna:  <a href="http://www.archivimmc.eu/cbr_mostra.php?cercainventario=7">http://www.archivimmc.eu/cbr_mostra.php?cercainventario=7</a></p>

## Section 2: technical description

<b>Metric data and shape of the hull</b>	The exemplar follows and show the typical characteristics and proportions of the largest bragozzi used for fishing since 19. Century: lenght over 12 m and more, flat-bottomed hull, square stern, characterized by sleek lines but with a robust structure and capable of developing considerable speed and power in fishing activities, with a good seaworthyness.
<b>Structural parts ( keel and frames)</b>	The internal structure is made up of a sturdy keel and bow and stern rods in oak wood, on which the frames are made of horizontal elements ( <i>piane</i> ) for the bottom and vertical ( <i>sancòni</i> ) for the sides, with the reinforcements and the cleats are grafted. The reinforcements for the engine, then removed in the first restoration in 1982 ca., was fixed are still visible.
<b>Planking ( external / internal)</b>	The planking courses are made of larch wood, replaced over time for some courses with different woods, of varying widths, and fixed to the frames from the outside; there are also longitudinal reinforcements ( <i>serrette</i> ) as in all traditional wooden constructions.
<b>Deck and openings</b>	The boat has three hatches, the two main ones located aft of the main mast and in the center, and the smaller one in the bow of the foremast. There are six cleats, 4 ( 2 for each side) at the bow, and 2 ( 1 for side) at stern.
<b>Sails and rig</b>	The rig features two masts, of which the shorter foresail and forward inclined, with two “al terzo” sails.
<b>Rudder and other steering elements</b>	The rudder is very wide and deep, as is typical in <i>bragozzi</i> , and can be hoisted with a hoist.
<b>Other significant elements</b>	As in the larger <i>bragozzi</i> , the hull is completely black, with only the upper band painted, and two white circles at the bow.
<b>Previous restorations</b>	The first restoration was made in 1982 ca. by Alvaro Farabegoli in his shipyard in Cesenatico, with the aim to restore the original aspect of this traditional type of boat, before its placement in the floating section of the museum.

## Annexes to the technical description

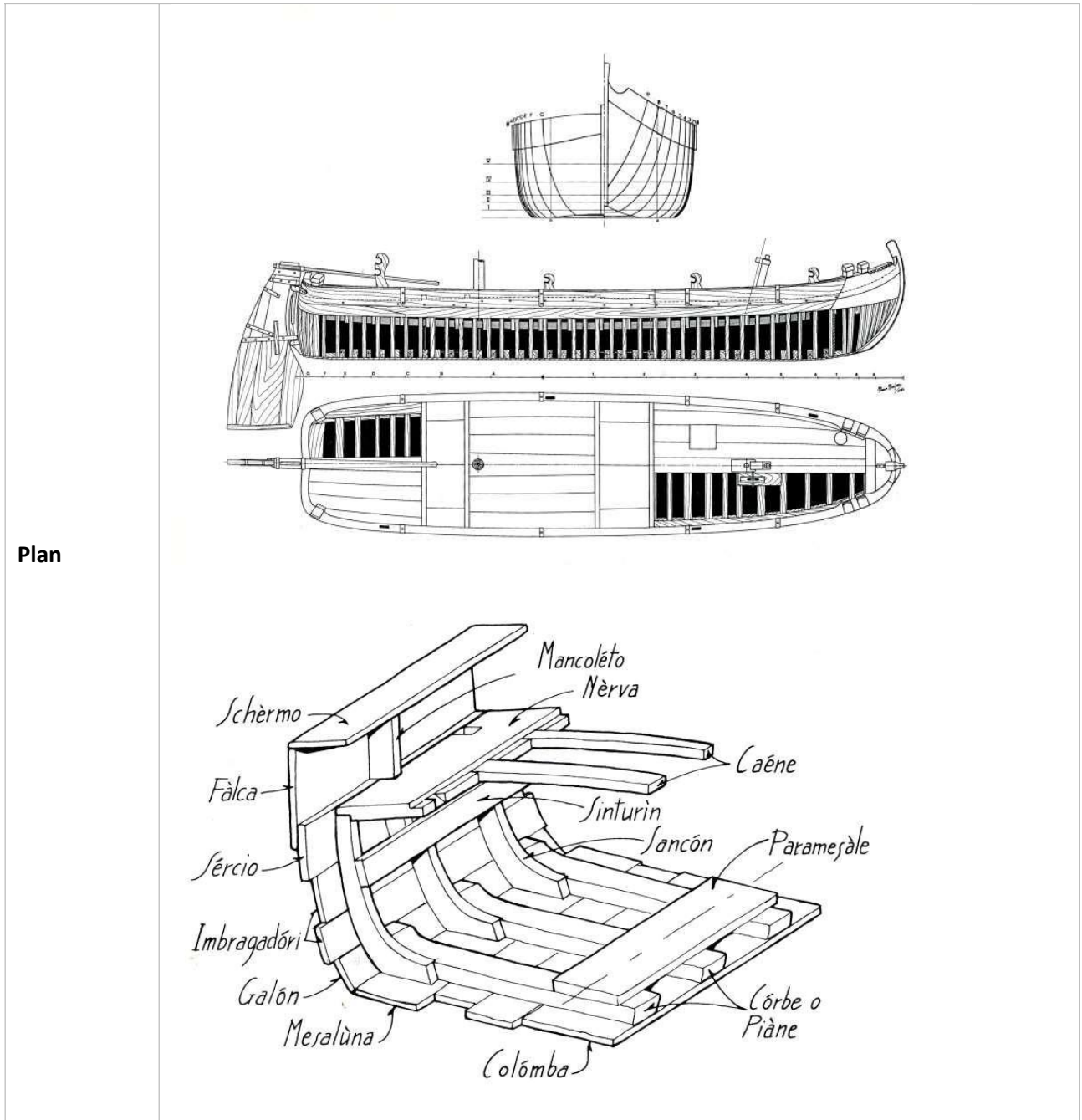



Docuementa  
tion about  
the history  
of the boat

*\*if available*



Mod. N. 2 Per le stazze eseguite con la bastimenti senza coperta e ai galleggianti coperta (art. XVIII delle istruzioni 25 L.

Certificato N. 7098

## MARINA MERCANTILE ITALIANA

### CERTIFICATO DI STAZZA

del (1) La Sb. denominat a SAN MARCO inscritta al N. 6101  
 del Registro Galleggianti del (2) Compartimento Marittimo di Venezia

SCAFO	Luogo e data di costruzione	<u>Chioggia - 1956</u>	Materiale di costruzione	<u>legno</u>
	Forma della prora	<u>ricurva</u>	Forma della poppa	<u>dritta</u>
	Numero degli alberi	<u>2 (due)</u>	Tipo dell'attrezzatura	<u>a braccata</u>
MACCHINA	Luogo e data di costruzione	<u>Milano - 1974</u>	Tipo e potenza	<u>n° 1 motore c.i. Diesel 42</u>
	Genere del propulsore	<u>alico</u>		<u>SS - Matr. 044917 - n° 6 cil. - p. mm. 130 - co.</u>
CALDAIA	Luogo e data di costruzione	<u>anonno</u>	Tipo	<u>mm. 145 - C.A. 145 a giri 1700/1°</u>

#### DIMENSIONI PRINCIPALI

<b>Lunghezza fuori tutto</b>	= Lunghezza massima dell'avanti della ruota di prora, sotto il bompresso, alla faccia posteriore dell'orlo di poppa	<u>13.88</u> m
<b>Lunghezza netta di stazza</b>	= Lunghezza dall'orlo superiore interno della suola, a fianco della ruota di prora, sino allo stesso punto a poppa, od all'orlo interno dello specchio di poppa, se la nave o galleggiante è a poppa quadra (art. 21 reg.)	<u>13.41</u> m
<b>Larghezza netta di stazza</b>	= Larghezza, alla ordinata maestra, fra gli orli superiori interni della suola (art. 21 reg.)	<u>3.69</u> m
<b>Profondità netta di stazza</b>	= Profondità, alla ordinata maestra, da una retta tesata fra gli orli superiori della suola alla gola del madiere accanto al paramozzale, dedotta la grossezza media delle serrette (art. 21 reg.)	<u>1.14</u> m

STAZZA	LORDA Tonnellate	<u>13.95</u>	(Vedi computo a tergo)
	NETTA	<u>9.49</u>	

#### PROCESSO VERBALE

IL CAPOSEZIONE  
 CAPITANO DI FREGATA (CP)  
 (Ugo BRESCA)

Quest'oggi 29 LUG. 1974 innanzi a me  
 in quest' CAPITANERIA DI PORTO di por-  
 to si è presentato il Signor ing. Canal il quale, dopo avermi mostrato il  
Luigi Cappato armatore del galleggiante sopra descritto mi ha dichiarato che egli ha  
 stazato detto galleggiante attenendosi strettamente alle regole sancite con R. Decreto n. 202 del 27 gennaio 1916,  
 e che, avendo riportato fedelmente e di sua propria mano nelle tabelle di questo certificato le dimensioni prese ed  
 i risultati dei calcoli fatti, come a tergo del presente, trovo che tale galleggiante ha una stazza lorda di tonnellate  
13.95 e una stazza netta di tonnellate 9.49. Avendogli io dato lettura dell'art. 481 del  
 Codice Penale approvato con R. Decreto 19 ottobre 1930 n. 1398, l'ho invitato, nei modi stabiliti dall'art. 193 del Co-  
 dice di procedura civile, approvato con R.D. 28 ottobre 1940 n. 1443, a prestar giuramento; ed egli, consapevole  
 dell'importanza morale del medesimo e del vincolo religioso che i credenti contraggono innanzi a Dio ed agli umi-  
 ni, ha giurato di aver dichiarato la pura verità.

In fede di che si è con me e con i testimoni sottoscritto.

Il Funzionario del R. I. NA. Perito stazatore  
VENEZIA 29 LUG 1974  
 Dato a \_\_\_\_\_ di \_\_\_\_\_ ISP. PRINC. DR. ING. LUIGI CANAL  
 L'Armatore Cappato Luigi I testimoni \_\_\_\_\_  
 CAPITANO DI FREGATA (CP)  
 (Ugo BRESCA) di porto

(1) Piroscalo, motonave, motoveliero con motore ausiliario, veliero o galleggiante.  
 (2) Compartimento marittimo - Circondario marittimo - Ufficio locale marittimo - Delegazione di spiaggia.

Photos  
before the  
restoration  
work



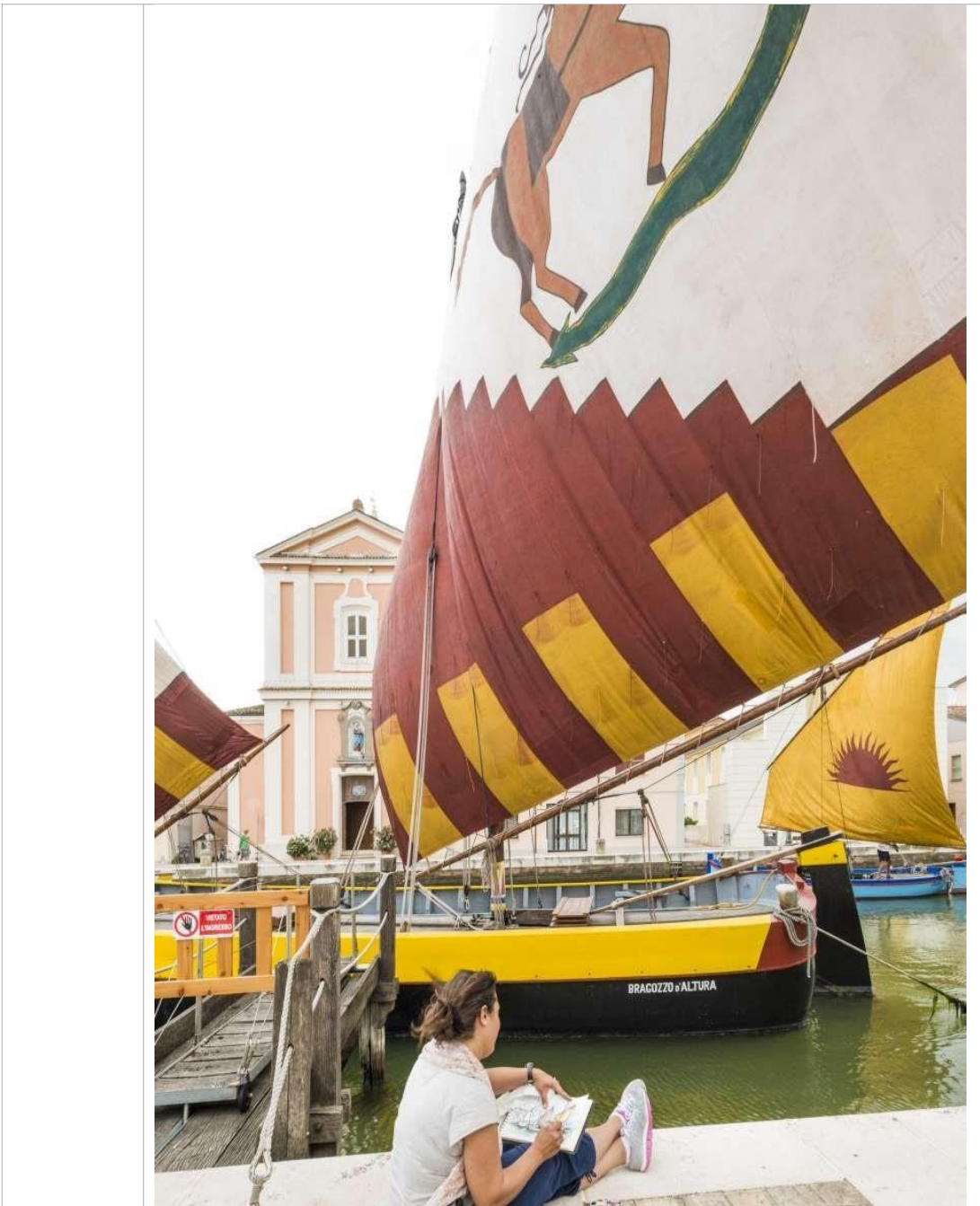

<b>Name of the compiler</b>	Davide Gnola (museum director / conservator)
<b>Date of compilation</b>	30 September 2021



**Photos**



## **PP 6 - CIHEAM IAMB**

### **Trechandiri Portus Veneris**



## Section 1: boat data

	<b>Motivation for the selection of the boat</b> (the grid has the function of identifying and exposing the reason that motivated the selection of this specific boat for restoration and documentation)
<b>Ethnographic / cultural significance</b>	Historical sailing ship, comparable to the boat type known in Greece as <i>Trechandiri</i> and in Turkey as <i>Tirhandil</i> . The sailing ship is about 100 years old. This boat type dates back to the ancient Greek ships of the classical period.
<b>Historical significance</b>	It Arrived in Italy in May 2002, bringing in Tricase Porto 98 Kurdish Iraqi refugees, fleeing from their own country.
<b>Technical / nautical significance</b>	Equippe with two lateen sails hoisted on two masts, of <i>aestra</i> and of <i>trinchetta</i> , through two antennas.
<b>Replica</b>	

	<b>Identification data</b>
<b>Current boat name</b>	Portus Venetia
<b>Current register number (if registered)</b>	n. 2GL13 in the Register of minor ships of the local maritime office of Coast Guard of Tricase (LE)
<b>Current harbour / location</b>	Tricase Porto (LE), Italy

<b>Current owner</b>	M h Tricase Municipality. Magna Grecia Mare Association is the ship owner
<b>Contact person / site</b>	Magna Grecia Mare Association <a href="mailto:info@magnagreciamare.it">info@magnagreciamare.it</a> <a href="mailto:relazioniesterne@magnagreciamare.it">relazioniesterne@magnagreciamare.it</a>

	<b>Material data</b>
<b>Boat type / Traditional type</b>	Historical sailing ship, comparable to the boat type known in Greece as <i>Trechandiri</i> and in Turkey as <i>Tirhandil</i> .
<b>Original function</b>	Unknow
<b>Rig</b>	Lateen
<b>Length</b>	13,76 m
<b>Breadth</b>	4,15 m
<b>Draught</b>	From below the keel to the waterline of the hull: About 1,80 m
<b>Tonnage or weight (if known)</b>	12,41 tons (gross weight) 8,44 tons (net weight)
<b>Main materials and construction features</b>	Different types of wood were used for its construction: fir, fruit pine, ash, olive wood, elm and mahogany. Some instruments are made of brass, steel and iron.



	<b>Historical data</b>
<b>Date / period of construction</b>	The sailing ship is about 100 years old
<b>Construction place / shipyard or builder</b>	The original place of construction is unknown
<b>Designer, if any</b>	Unknown
<b>Historical presentation</b>	<p><i>Brief description of the life of the boat with reference to its original use and to events preceding the present restoration; indicate here also the previous names and register numbers, and previous owners, and restorations</i></p> <p>The sailing ship Portus Veneris arrived in Italy in May 2002, bringing in Tricase Porto 98 Kurdish Iraqi refugees, fleeing from their own country. It was discovered by some members of the Magna Grecia Mare Association of Tricase in August 2003. The first restoration was done in August 2004. Once restored it became the flagship of the fleet of the Museum of Boats and emblem of the Tricase Port Museum. The sailing ship has been used as the seat of cultural events and appointments and institutional representation of the Port Museum and CIHEAM Bari. It has also served as a training ship where to learn and practice the traditional manoeuvres during the courses of Lateen sailing of the Municipal School of Lateen Sailing and Ancient Seamanship and, for what it represents through its history, it has been a symbol of the historical link of the city of Tricase with the other peoples of the Mediterranean.</p>
<b>Bibliography / links</b>	Give a bibliography of published books or articles, or links to Internet resources (e.g. site, social) on this specific boat (not about type or in general)



## Section 2: technical description

<p><b>Metric data and shape of the hull</b></p>	<p><i>Indicate the salient measurements (in addition to those of length and width) and describe the general shape of the hull (e.g. sheer, length / width proportion, etc.)</i></p> <p>The sailing ship Portus Veneris is 14 meters long and more than 3 meters large. Its bow and stern are soared up and the bow's wheel can be inscribed in a quarter of a circle.</p>
<p><b>Structural parts (keel and frames)</b></p>	<p><i>Description of the structure of the boat, also indicating the number and measures of the frames, and other structural</i></p> <p>The structural elements of the sailing ship (keel, frames, beam and gunwale) are made of oak wood. After the renewal work (within the ARCA ADRIATICA project) the keelson has been changed and constructed in mahogany wood.</p>
<p><b>Planking (external / internal)</b></p>	<p><i>Description of the planking, with measures, and type of waterproofing (e.g. caulking, epoxy, others)</i></p> <p>The planking is made of maritime pine wood. The caulking was made through hemp and cotton fibres in-between the planks.</p>
<p><b>Deck and openings</b></p>	<p><i>Description of the deck and the number and size of the different openings</i></p> <p>The sailing ship has three openings on the deck: the opening on the stern accessed to the hull area. The central opening provides access to the cargo. The fore peaks for the anchors.</p>
<p><b>Sails and rig</b></p>	<p><i>Describe in detail and provide the type (e.g. "al terzo", lateen, auric, Marconi, etc.) and other features of the sails, and of the fixed and running rigging</i></p> <p>Equipped with two lateen sails hoisted on two masts, of maestra and of trinchetta, through two antennas. The antennas are made of two parts linked among them thanks to a particular knot called "a lapazza". A mobile bowsprit can hoist sails of different sizes.</p>

	<i>The sails are made of cotton. The sailing ship is equipped with wooden turning blocks.</i>
<b>Rudder and other steering elements</b>	<i>The Port<sup>u</sup> Veneris' drawbar is made of oak wood and sti<sup>c</sup> ked to the hull through steel piv<sup>t</sup>s.</i>
<b>Other significant elements</b>	Due to technical safety measures as well as law disposals, the sailing ship is also endowed with inboard propulsion engine (IVECO AIFO 150 Hp).
<b>Previous restorations</b>	Arrived in Italy in May 2002, it was discovered by some members of the <i>Magna Grecia Mare</i> Association of Tricase in August 2003 The first restoration was done by the <i>Magna Grecia Mare</i> Association in August 2004, on the service area in front of the local maritime office of the Coast Guard of Tricase (LE), with the help of the shipwrights Giovanni and Antonio Frassanito from Marittima (Lecce - Italy) and Toto Ruberto, ship's carpenter of the <i>Magna Grecia Mare</i> Association.

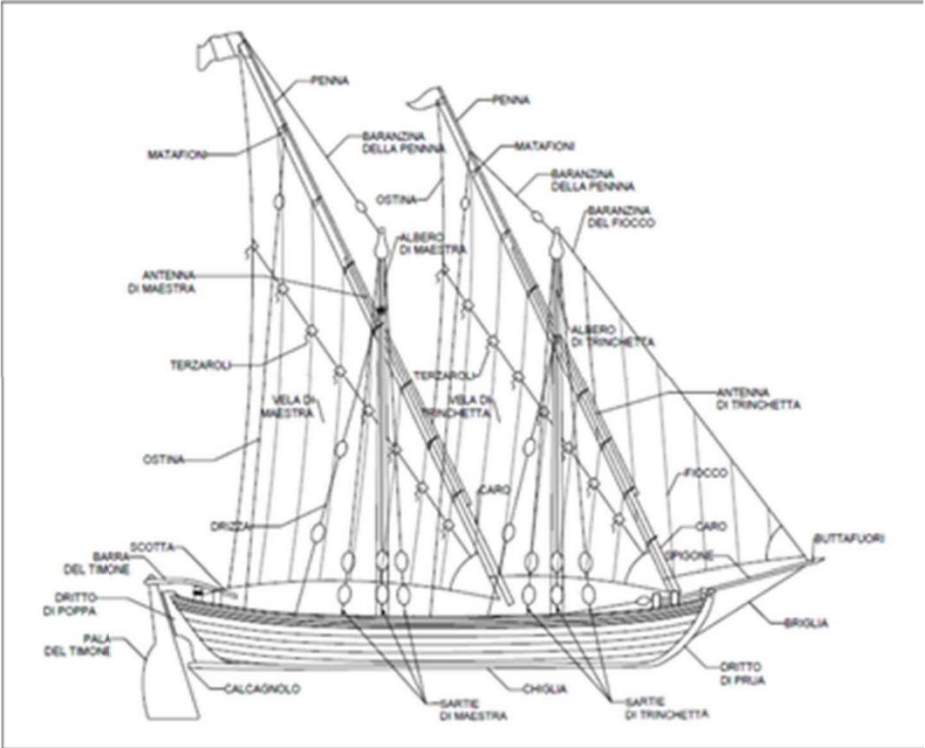
## Annexes to the technical description

<p style="text-align: center;"><b>Plan</b></p>	<p>Add a plan of the boat, or sketch, not important if made by CAD or laser scanner or by freghand, but mandatory with 3 views (side, front, top), and in addition 1 side view with sail/s and rig, views of details if important; all the views with the referencemeasures</p> 
<p><b>Documentation about the history of the boat</b> <i>*if available</i></p>	<p>Collect and reproduce in digital support (e.g. PDF dossier) all the documentation from various sources (e.g. old photos, magazine articles, book pages, oral records transcription, etc.) related to the boat life.</p>

<p><b>Photos</b></p>	
	
<p><b>Name of the compiler</b></p>	<p>Silvia Lecci, Monica Martella</p>
<p><b>Date of compilation</b></p>	<p>09/03/2022</p>

## PP 6 - CIHEAM IAMB

### Schifetto *Delfino*



## Section 1: boat data

	<p><b>Motivation for the selection of the boat</b> (the grid has the function of identifying and exposing the reason that motivated the selection of this specific boat for restoration and documentation)</p>
<b>Ethnographic / cultural significance</b>	<p><i>E.g. does the boat represent traditional boat types (e.g. bragozzo, batana, etc.) or traditional fishing techniques, crafts, traditions?)</i></p> <p>Delfino is a historical fishing boat called “schifetto”</p>
<b>Historical significance</b>	<p><i>Is the boat related to any historical event? (include sports scores of particular relevance, personalities, etc.)</i></p> <p>DELFINO is the oldest fishing boat of the Port Museum of Tricase, whose typology is called schifetto”</p>
<b>Technical / nautical significance</b>	<p><i>Do the boat has particular design solutions, or represents nautical types of boats (e.g. Olympic classes, series, etc...), or the work of some famous designer?</i></p> <p>DELFINO” is the oldest fishing boat of the Port Museum of Tricase, whose typology is called schifetto”. It is one of the few remaining boats in the low Salento area of Puglia Region, which features a raw-sailing propulsion system.</p>
<b>Replica</b>	<p><i>Is the boat an exact reproduction of a boat matching one of the above criteria?</i></p> <p>“</p>

	<b>Identification data</b>
<b>Current boat name</b>	DELFINO a

<b>Current register number (if registered)</b>	
<b>Current harbour / location</b>	Tricase Porto (LE) - Italy
<b>Current owner</b>	MAGNA GRECIA MARE ASSOCIATION
<b>Contact person / site</b>	Magna Grecia Mare Association <a href="mailto:info@magnagreciamare.it">info@magnagreciamare.it</a> <a href="mailto:relazioniesterne@magnagreciamare.it">relazioniesterne@magnagreciamare.it</a>

	<b>Material data</b>
<b>Boat type / Traditional type</b>	<i>Name of the traditional typology (e.g. bragozzo, batana, also giving further specification related to place) or boat's type (e.g. cutter, dinghy, etc.)</i> Fishing boat type: "Schifetto"
<b>Original function</b>	Fishing
<b>Rig</b>	Lateen
<b>Length</b>	4,46 m
<b>Breadth</b>	1,71 m
<b>Draught</b>	



<b>Tonnage or weight (if known)</b>	
<b>Main materials and construction features</b>	<p><i>Indicate main construction features, e.g. hull materials and type of building (e.g. traditional wood building, oak wood, metal hull, etc.)</i></p> <p>The boat's wheel was built in solid wood, the mast was built in pitch-pine wood</p>

	<b>Historical data</b>
<b>Date / period of construction</b>	The 50s
<b>Construction place / shipyard or builder</b>	<p><i>Indicate the place or if unknown the area, and the name of shipyard or shipbuilder</i></p> <p>Cantiere Frasanito in Marittima di Diso (Lecce – Italy)</p>
<b>Designer, if any</b>	
<b>Historical presentation</b>	<p><i>Brief description of the life of the boat with reference to its original use and to events preceding the present restoration; indicate here also the previous names and register numbers, and previous owners, and restorations</i></p> <p>The boat was built upon request of a local fisher belonging to a family with long tradition in the sector. Until the seventies the boat was used for fishing along the coast, afterward it was used for pleasure sailing and then abandoned and forgotten by local community. In 1997 it was found in an olive grove and restored. The restoration concerned the main structural items in order to allow the use of the boat on the sea. Once restored, it was the first boat to be included in the Museum of Sea Art and Traditional Boats of the Port Museum of Tricase. Then, from 2006 to 2018, the Delfino was used as the service boat of the vessel "Portus Veneris".</p>

	<p style="text-align: center;">1</p> <p style="text-align: right;">n</p> <p>Since 20 8 the Delfino has been in the shipyard being i bad state of repair and lack of funds has not allowed its restoration so far.</p>
<b>Bibliography / links</b>	Give a bibliography of published books or articles, or links to Internet resources (e.g. site , social) on this specific boat (not about type or in general)

## Section 2: technical description

<p><b>Metric data and shape of the hull</b></p>	<p><i>Indicate the salient measurements (in addition to those of length and width) and describe the general shape of the hull (e.g. sheer, length / width proportion, etc.)</i></p> <p>Delfino is a historical fishing boat called “schifetto” which features a raw-sailing propulsion system. It is about 4,80 m long and its bow and stern have a pointed end, therefore the boat can be sailed in both senses.</p>
<p><b>Structural parts (keel and frames)</b></p>	<p><i>Description of the structure of the boat, also indicating the number and measures of the frames, and other structural parts</i></p>
<p><b>Planking (external / internal)</b></p>	<p><i>Description of the planking, with measures, and type of waterproofing (e.g. caulking, epoxy, others)</i></p>
<p><b>Deck and openings</b></p>	<p><i>Description of the deck and the number and size of the different openings</i></p> <p>The main deck has two areas: an area is located at the bow is called <i>tamburello</i> and the other is located at the stern and is called <i>sanula</i>. Between the two areas a plank for sailing is provided with a hole where the mast can be placed.</p>
<p><b>Sails and rig</b></p>	<p><i>Describe in detail and provide the type (e.g. “al terzo”, lateen, auric, Marconi, etc.) and other features of the sails, and of the fixed and running rigging.</i></p> <p>Delfino is equipped with a lateen sail, a mast (which can be extracted), a antenna (separated into two part connected by a knot type called “a lapazza”), the sail made of cotton. The rigging is composed of: 1 shroud, 1 halyard to hoist the antenna, a metal connection (<i>trozza</i>) between the antenna and the mast, two ropes to address the boat depending on the needs.</p>
<p><b>Rudder and other steering elements</b></p>	<p>Describe the type and material of the rudder (e.g. tiller, wheel) and the other steering parts.</p>

	A wooden helm governed by a bar. The helm can be extracted when the boat is not used.
<b>Other significant elements</b>	<p><i>E.g. inboard or outboard engine, changes made to the original hull, presence of incongruous elements, elements inserted for technical or regulatory reasons, etc.</i></p> <p>Delfino has only a raw-sailing propulsion system</p>
<b>Previous restorations</b>	<p><i>Indication and description of the previous restorations, if any, with indication of year, place/shipyard, replaced parts and work, if known</i></p> <p>D In 1997 Delfino was subject to different renovations. The planking, the prow, the lower greenhouse, parts of the stern and some armrest were replaced. Moreover it was enamelled, caulked, nailed and painted.</p>

Name of the compiler	Silvia Lecci and Monica Martella (CIHEAM Iamb)
Date of compilation	09/03/20 2

## Annexes to the technical description

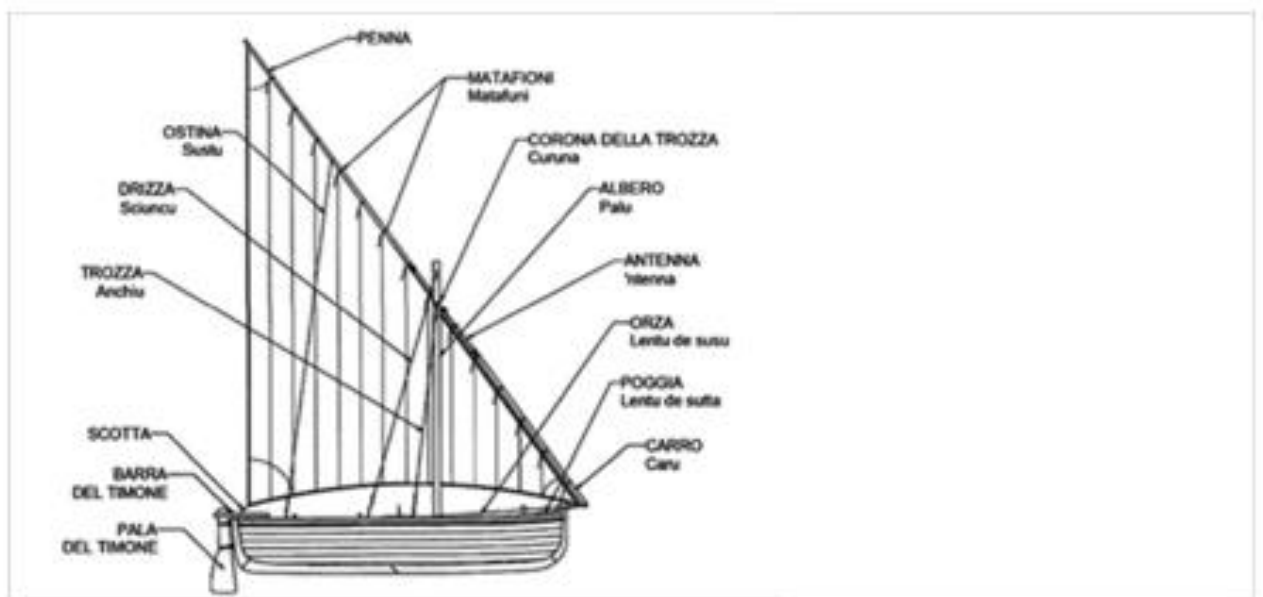
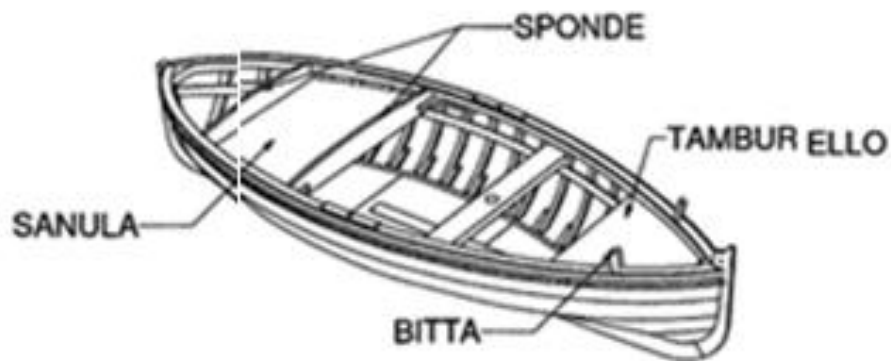

Insert a photo with a general view of the boat in  
the frame below



## **PP 7 - MUNICIPALITY OF SAN BENEDETTO DEL TRONTO**

### **Lancetta *Tastutina***



## Section 1: boat data

	<p><b>Motivation for the selection of the boat</b> (the grid has the function of identifying and exposing the reason that motivated the selection of this specific boat for restoration and documentation)</p>
<b>Ethnographic / cultural significance</b>	<p>This boat was one of the most common and useful boats during the 20th century. It could only carry two or three people. The sails had different symbols according to the maritime families, thus they also represented the community and the hard and risky work they used to do. These were personalised with drawings, writings and even sacred symbols (e.g. the cockerel represented St. Peter). The “lancetta” or lancettuccia were used by the Paranze (bigger boats) to bring the fish ashore, because they were more manageable and faster.</p>
<b>Historical significance</b>	<p>The boat is related to a wealthy family, the Palestini family, who donated it in the late 1900.</p>
<b>Technical / nautical significance</b>	<p>None</p>
<b>Replica</b>	<p>The boat is the exact replica of the lancetta (launch) that fisher would use in the past. In its restoration original colouring and forms were maintained with better and long lasting materials.</p>

	<b>Identification data</b>
<b>Current boat name</b>	Tastutina



<b>Current register number (if registered)</b>	NA
<b>Current harbour / location</b>	PORT, SAN BENEDETTO DEL TRONTO, IT
<b>Current owner</b>	MUNICIPALITY OF SAN BENEDETTO DEL TRONTO, IT
<b>Contact person / site</b>	SERGIO TREVISANI, PROJECT MANAGER MUNICIPALITY OF SAN BENEDETTO DEL TRONTO, IT. 

	<b>Material data</b>
<b>Boat type / Traditional type</b>	Lancetta- Launch boat
<b>Original function</b>	Fishing, fish transportation to shore
<b>Rig</b>	Al terzo
<b>Length</b>	460 cm
<b>Breadth</b>	153 cm

<b>Draught</b>	From below the keel to the waterline of the hull
<b>Tonnage or weight (if known)</b>	Not known
<b>Main materials and construction features</b>	Woods used for replacing the wooden damaged and old parts: oak, spruce, larch, quality marine plywood.

	<b>Historical data</b>
<b>Date / period of construction</b>	1929
<b>Construction place / shipyard or builder</b>	Shipyard agency SEA, MASTER OF SHIP building: GIOACCHINO MOSCA
<b>Designer, if any</b>	Patrizia Capacchietti for the design of the sail; Engineers Michele di Carlo & Raffaele Pierucci for the technical design
<b>Historical presentation</b>	Tastutina was built in Porto San Giorgio in 1929 and belonged to the Palestini family, whose owner was nicknamed Tastuto (hence the name). It is a small lancet boat (therefore a type of boat even smaller than the usual "launch" boat). The boat was then donated to the Municipality which restored it and brought it back to live and made it once again navigable.
<b>Bibliography / links</b>	<a href="https://www.jacklabolina.it/tastutina-e-stella-del-mare/">https://www.jacklabolina.it/tastutina-e-stella-del-mare/</a> <a href="http://www.ancoraonline.it/2015/07/24/la-lancettuccia-tastutina-e-tornata-in-mare/">http://www.ancoraonline.it/2015/07/24/la-lancettuccia-tastutina-e-tornata-in-mare/</a> <a href="https://www.comunesbt.it/Torna-in-mare-la-lancettuccia-Tastutina">https://www.comunesbt.it/Torna-in-mare-la-lancettuccia-Tastutina</a>

## Section 2: technical description

<b>Metric data and shape of the hull</b>	<p><b>Measurements:</b></p> <p>total width (with sail): 153 cm</p> <p>total length (with sail): 578 cm</p> <p>total height (with sail): 722 cm</p> <p>total width (without sail):153 cm</p> <p>total length (without sail): 460 cm</p> <p>total height (without sail): 107 cm</p>
--	---

<p><b>Structural parts (keel and frames)</b></p>	<p>Description of the structure of the boat</p> <p><b>keel measurement:</b></p> <ul style="list-style-type: none"> <li>- thickness 11 cm</li> <li>- width 4,5 cm</li> <li>- length 460 cm</li> <li>- length: variable</li> </ul> <p><b>longitudinal skeleton:</b></p> <ul style="list-style-type: none"> <li>- number of pieces: 7</li> <li>- thickness 2 cm</li> <li>- width 11 cm</li> <li>- length: variable</li> </ul> <p><b>latitudinal skeleton:</b></p> <ul style="list-style-type: none"> <li>- number of pieces: 47</li> <li>- thickness 4 cm</li> <li>- width 4 cm</li> <li>- length: variable</li> </ul>
<p><b>Planking (external / internal)</b></p>	<p>Description of the planking</p> <p><b>external planking</b></p> <ul style="list-style-type: none"> <li>- number of planking: 16</li> </ul>

	<ul style="list-style-type: none"> <li>- thickness: 2 cm</li> <li>- width: 12 cm</li> <li>- length: variable</li> </ul> <p><b>internal planking</b></p> <ul style="list-style-type: none"> <li>- number of planking: 12</li> <li>- thickness: 2 cm</li> <li>- width: 8 cm</li> <li>- length: variable</li> </ul> <p><b>bow and stern seats:</b></p> <ul style="list-style-type: none"> <li>- number of boards: 31 cover + 2 seats</li> <li>- cover thickness: 2 cm</li> <li>- cover width: 22 cm</li> <li>- seat thickness: 4 cm</li> <li>- seat width: 14 cm</li> <li>- seat length: 136</li> </ul>
<b>Deck and openings</b>	NA
<b>Sails and rig</b>	“al terzo” rig, one sail
<b>Rudder and other steering elements</b>	Tiller rudder

<b>Other significant elements</b>	NA
<b>Previous restorations</b>	Tastutina had been previously restored in 2014/2015.

### Pan- Render of the boat

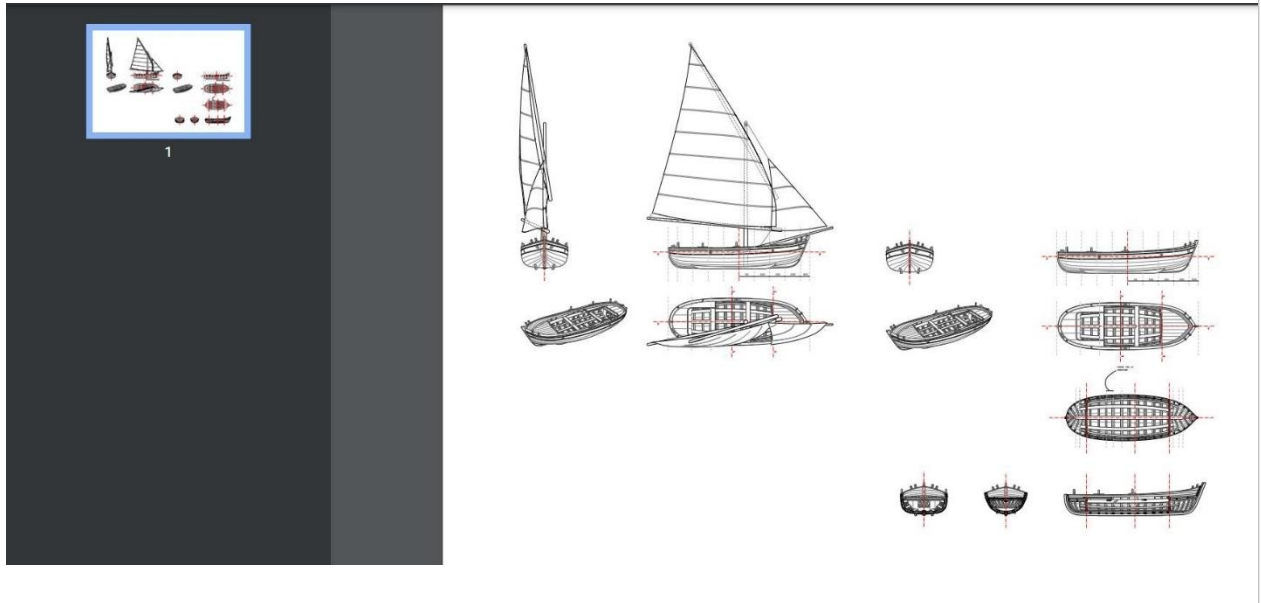

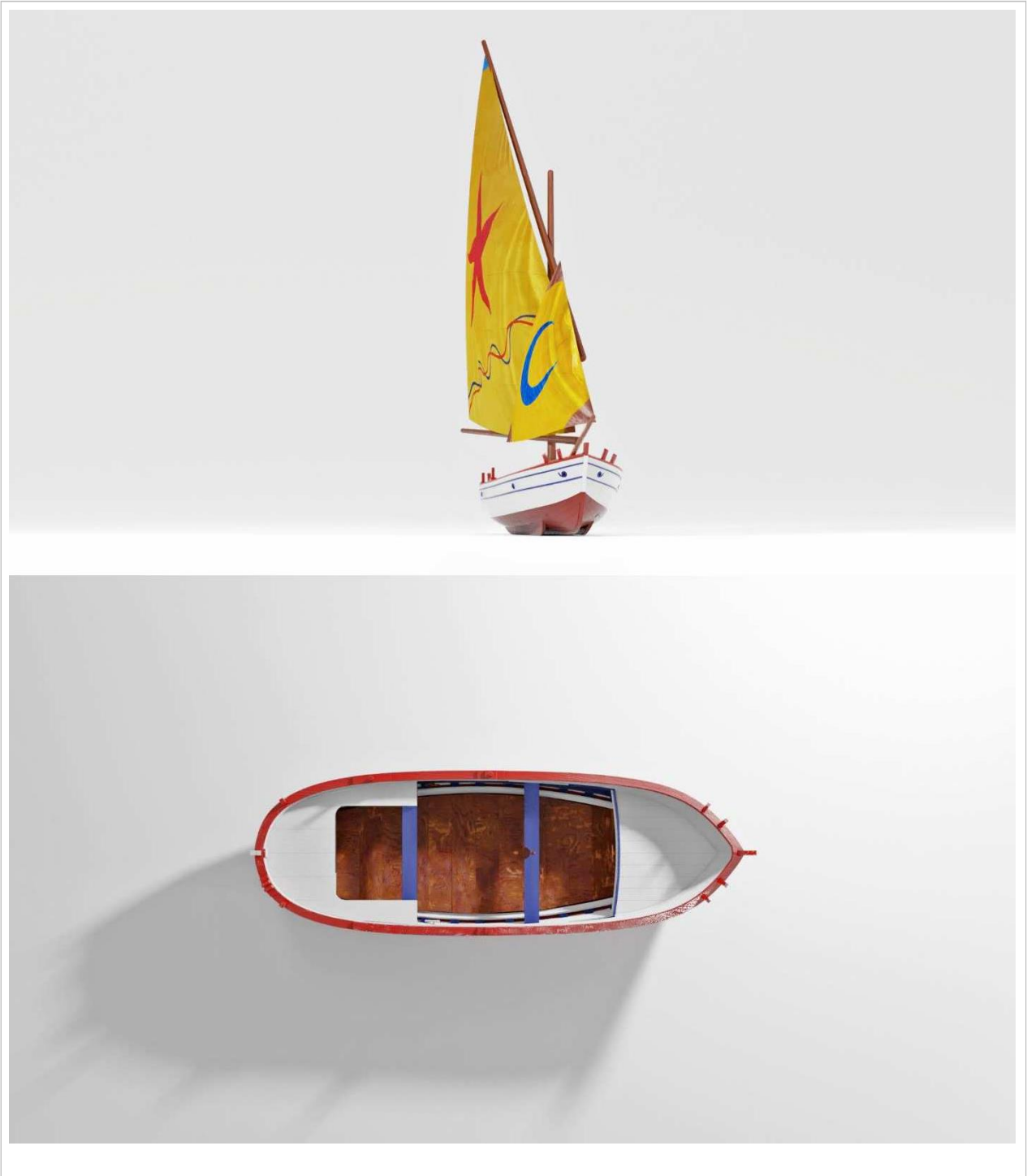



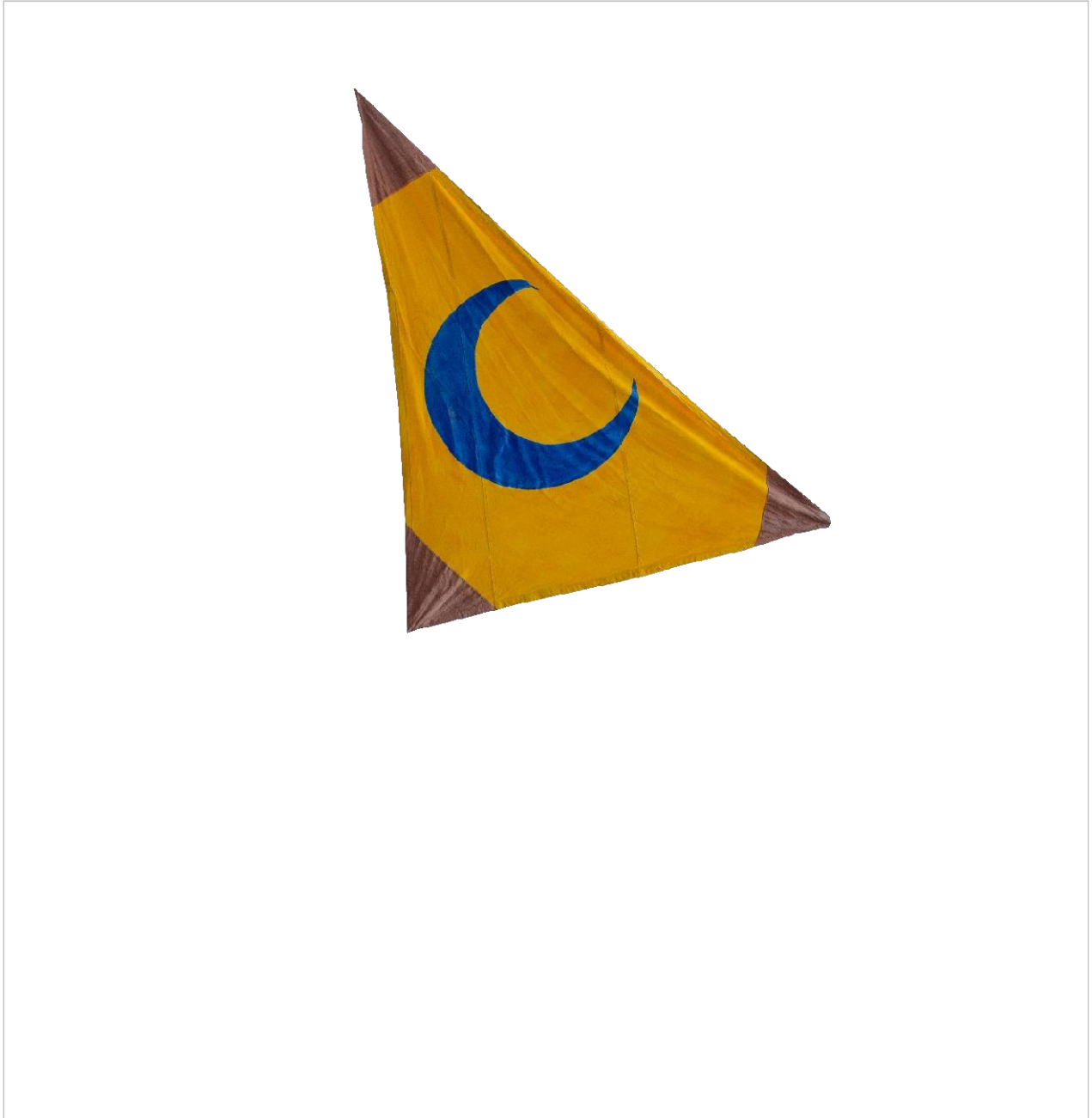



Insert a photo with a general view of the boat in the frame below



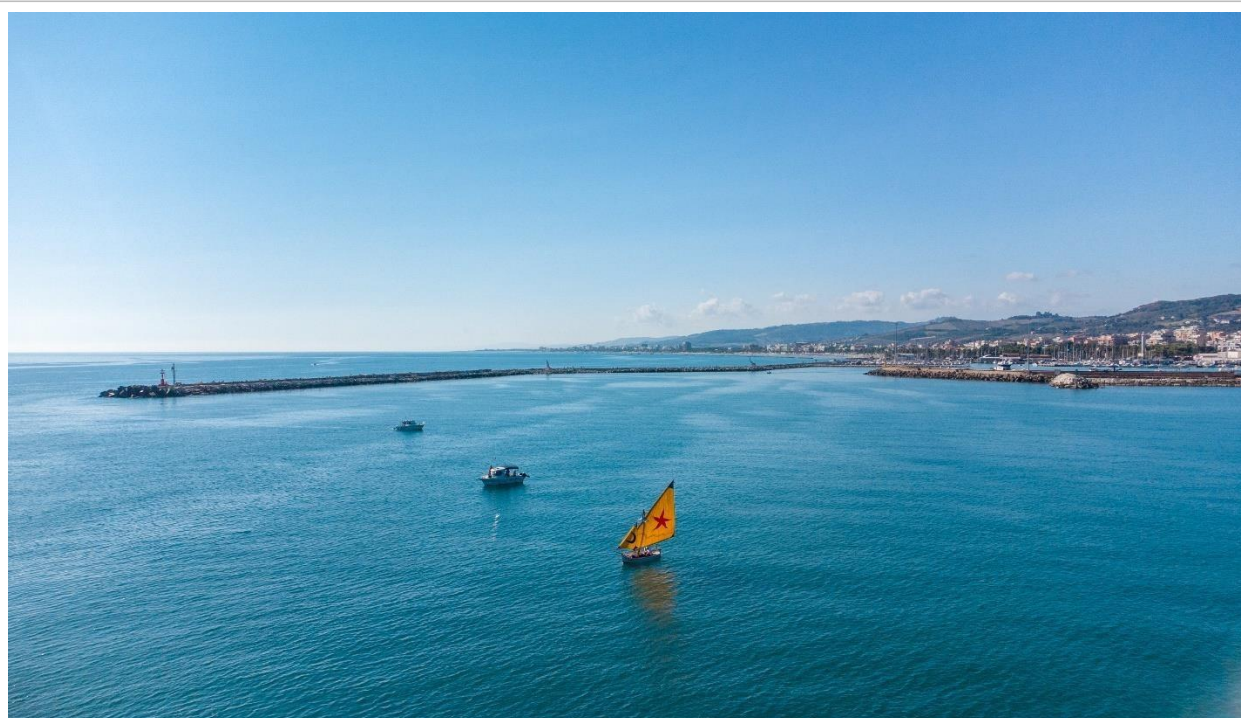





## PP 7 - MUNICIPALITY OF SAN BENEDETTO DEL TRONTO

### Lancetta *Stella del Mare*



## Section 1: boat data

	<b>Motivation for the selection of the boat</b>
<b>Ethnographic / cultural significance</b>	This boat was one of the most common and useful boats during the 20th century. It could only carry two or three people maximum. The sails had different symbols according to the maritime families, thus they also represented the community and the hard and risky work they used to do. These were personalised with drawings, writings and even sacred symbols (e.g. the cockerel represented St. Peter). This specific boat however is unknown of its kind, but based on its characteristics, use, and measures it resembles very much a “lancetta” type of boat.
<b>Historical significance</b>	The boat Stella del mare (Star of the Sea) was named by Gigi Anelli because it was an anonymous boat thrown out in a garden and we don't even know which type of boat it is, even though it is similar to a launch small boat. The boat was acquired and restored for the first time in spring/summer 2015, however its date of construction remains unknown.
<b>Technical / nautical significance</b>	None
<b>Replica</b>	The boat is the exact replica of the lancetta (launch) that fisher would use in the past, however its origins are unclear.

	<b>Identification data</b>
<b>Current boat name</b>	Stella del Mare

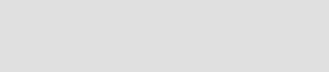

<b>Current register number (if registered)</b>	NA
<b>Current harbour / location</b>	FISH MUSUEM, SAN BENEDETTO DEL TRONTO, IT
<b>Current owner</b>	MUNICIPALITY OF SAN BENEDETTO DEL TRONTO, IT
<b>Contact person / site</b>	SERGIO TREVISANI, PROJECT MANAGER MUNICIPALITY OF SAN BENEDETTO DEL TRONTO, IT. 

	<b>Material data</b>
<b>Boat type / Traditional type</b>	Launch boat – alike
<b>Original function</b>	Fishing, fish transportation to shore
<b>Rig</b>	Al terzo
<b>Length</b>	460 cm
<b>Breadth</b>	153 cm

<b>Draught</b>	From below the keel to the waterline of the hull
<b>Tonnage or weight (if known)</b>	Not known
<b>Main materials and construction features</b>	Woods used for replacing the wooden damaged and old parts: oak, spruce, larch, quality marine plywood.

	<b>Historical data</b>
<b>Date / period of construction</b>	Unknown
<b>Construction place / shipyard or builder</b>	Shipyard agency SEA, MASTER OF SHIP building: GIOACCHINO MOSCA
<b>Designer, if any</b>	Patrizia Capacchietti for the design of the sail, and Michele di Carlo & Raffaele Pierucci for the technical design
<b>Historical presentation</b>	The boat, even though its origins are unknown, is very much alike to the lancetta type, therefore it is assumed that its use coincided with the lancetta's, that is for fishing and fish transportation during the 20 <sup>th</sup> century. Traditionally boats of these size and model, were all used by fishermen to fish and carry the fish from bigger boats to the shore.
<b>Bibliography / links</b>	<a href="https://www.jacklabolina.it/tastutina-e-stella-del-mare/">https://www.jacklabolina.it/tastutina-e-stella-del-mare/</a> <a href="http://www.ancoraonline.it/2015/07/24/la-lancettuccia-tastutina-e-tornata-in-mare/">http://www.ancoraonline.it/2015/07/24/la-lancettuccia-tastutina-e-tornata-in-mare/</a> <a href="https://www.comunesbt.it/Torna-in-mare-la-lancettuccia-Tastutina">https://www.comunesbt.it/Torna-in-mare-la-lancettuccia-Tastutina</a>

## Section 2: technical description

<b>Metric data and shape of the hull</b>	<p>Measurements:</p> <p>total width (with sail): 153 cm</p> <p>total length (with sail): 578 cm</p> <p>total height (with sail): 722 cm</p> <p>total width (without sail):153 cm</p> <p>total length (without sail): 460 cm</p> <p>total height (without sail): 107 cm</p>
--	--

<p><b>Structural parts (keel and frames)</b></p>	<p><b>Structure of the boat</b></p> <p>keel measurement:</p> <ul style="list-style-type: none"> <li>- thickness 11 cm</li> <li>- width 4,5 cm</li> <li>- length 460 cm</li> <li>- length: variable</li> </ul> <p><b>Longitudinal skeleton:</b></p> <ul style="list-style-type: none"> <li>- number of pieces: 7</li> <li>- thickness 2 cm</li> <li>- width 11 cm</li> <li>- length: variable</li> </ul> <p><b>Latitudinal skeleton:</b></p> <ul style="list-style-type: none"> <li>- number of pieces: 47</li> <li>- thickness 4 cm</li> <li>- width 4 cm</li> <li>- length: variable</li> </ul>
--	--

<p><b>Planking (external / internal)</b></p>	<p><b>External planking</b></p> <ul style="list-style-type: none"> <li>- number of planking: 16</li> <li>- thickness: 2 cm</li> <li>- width: 12 cm</li> <li>- length: variable</li> </ul>
	<p><b>Internal planking</b></p> <ul style="list-style-type: none"> <li>- number of planking: 12</li> <li>- thickness: 2 cm</li> <li>- width: 8 cm</li> <li>- length: variable</li> </ul>
	<p><b>Bow and stern seats</b></p> <ul style="list-style-type: none"> <li>- number of boards: 31 cover + 2 seats</li> <li>- cover thickness: 2 cm</li> <li>- cover width: 22 cm</li> <li>- seat thickness: 4 cm</li> <li>- seat width: 14 cm</li> <li>- seat length: 136 -</li> </ul>

<b>Deck and openings</b>	NA
<b>Sails and rig</b>	“al terzo” rig, one sail
<b>Rudder and other steering elements</b>	Tiller rudder
<b>Other significant elements</b>	NA
<b>Previous restorations</b>	None

Insert a reduced plan of the boat in the frame below

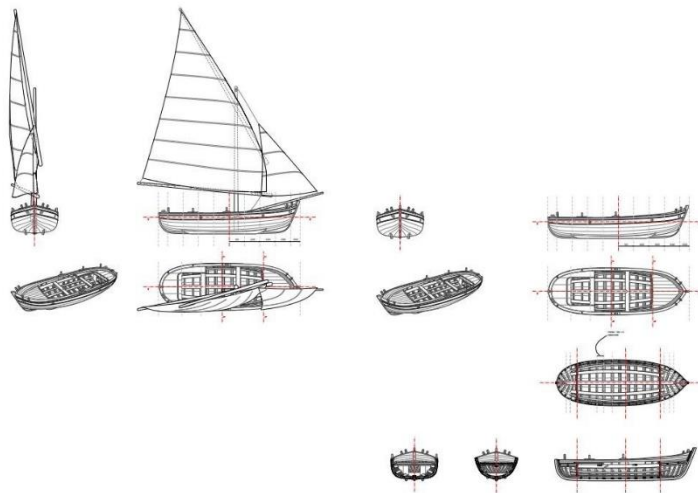

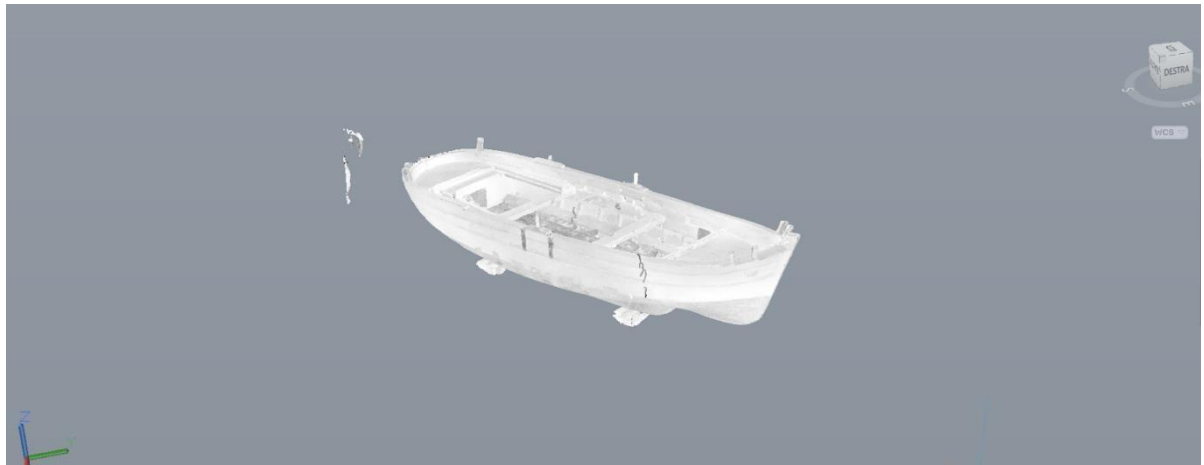



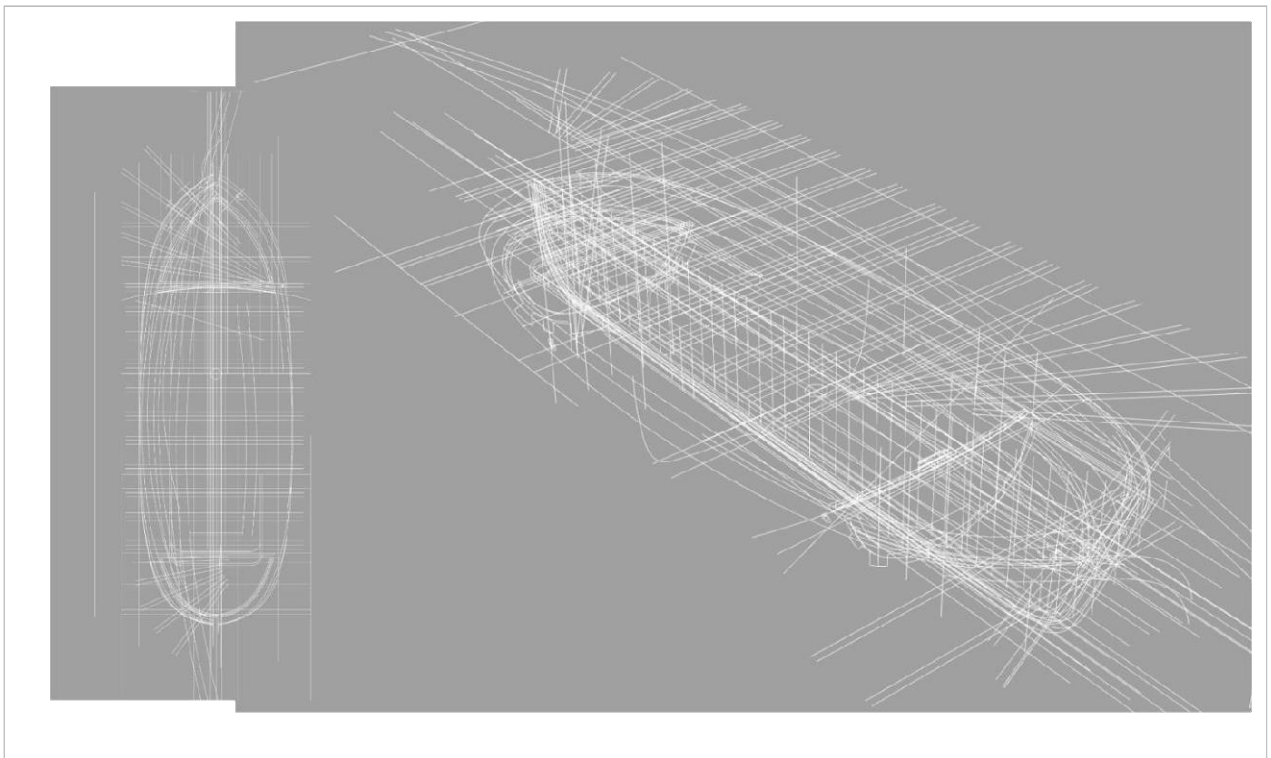

General view









## **PP 9 - MUNICIPALITY OF TKON**

### **Gajeta Bruno**



## Section 1: boat data

	<p><b>Motivation for the selection of the boat</b> (the grid has the function of identifying and exposing the reason that motivated the selection of this specific boat for restoration and documentation)</p>
<b>Ethnographic / cultural significance</b>	Gajeta is a traditional boat in Dalmatia region. This project of restoration of authentic boats is important for the preservation of Croatian traditional shipbuilding, which is an important part of Croatian cultural and national heritage.
<b>Historical significance</b>	Gajeta is a ship that has been built in the Mediterranean since ancient times, and is also mentioned in Homer's epics. Gajeta was built in all parts of the Adriatic, so in Croatian traditional shipbuilding there are several significant different designs, such as gajeta Lovranka or Lovranski guc, Komiška falkuša, Korčula gajeta and Betina gajeta. They were mostly used for transporting people, various cargoes and even cattle as well as for fishing with nets
<b>Technical / nautical significance</b>	Gajeta from Tkon represents the traditional shipbuilding heritage of the region of island Pašman. It is a fishing boat with a more rounded shape and a wider bow, which makes her different from other designs in the central Dalmatian area
<b>Replica</b>	This gajeta was originally built in 1940 on the island of Pašman. The original shipbuilder is unknown. The main goal of this reconstruction was preserving the original hull form as well as the original structural arrangement.

	<b>Identification data</b>
<b>Current boat name</b>	Bruno
<b>Current register number (if registered)</b>	BG 321

<b>Current harbour / location</b>	Tkon, island Pašman
<b>Current owner</b>	The owner of the gajeta is the Association for the Promotion of Sailing and Rowing with Traditional Boats on the Island of Pašman.
<b>Contact person / site</b>	

	<b>Material data</b>
<b>Boat type / Traditional type</b>	Traditional boat gajeta.
<b>Original function</b>	Fishing, passengers transportation
<b>Rig</b>	The drive was traditionally oars.
<b>Length</b>	Loa = 7.55 m
<b>Breadth</b>	B = 2.65 m
<b>Draught</b>	D = 0.5 m
<b>Tonnage or weight (if known)</b>	
<b>Main materials and construction</b>	Hull materials and type of building (e.g. traditional wood building, oak wood, spruce, fir, ash)



<b>features</b>	
-----------------	--

	<b>Historical data</b>
<b>Date / period of construction</b>	1940.
<b>Construction place / shipyard or builder</b>	Island Pašman. The original shipbuilder is not known.
<b>Designer, if any</b>	Designer is not known.
<b>Historical presentation</b>	Gajeta was mostly used for transporting people, various cargoes and for fishing with nets. An interesting thing about this gajeta is the fact that during II. World War II served, except for fishing, to transport passengers from the island to the mainland and vice versa.
<b>Bibliography / links</b>	Teodor Bernardi: Konstrukcija drvenih brodova, Sveučilište u Zagrebu, Zagreb, 1964. Lucijano Keber: Tradicionalne brodice hrvatskog Jadrana, Architectura navalis Adriatica, Tehnički muzej, Zagreb, 2002. Roko Markovina, Tonči Ukalović: Tradicionalna tehnologija gradnje korčulanske barke – brodice (ribarice-gajete), Simpozij Teorija i praksa brodogradnje SORTA 2010, Split-Lumbarda-Korčula, 07.-09.10.2010.

## Section 2: technical description

<b>Metric data and shape of the hull</b>	Gajeta was built in all parts of the Adriatic, so in Croatian traditional shipbuilding there are several significant different designs. The analysis of the documentation of traditional boat gajeta gave more data on their structure and methods of construction. Their length ranged between 4 and 10 meters. Gajeta is a real multi-purpose ship, so there are many forms of form. It is a traditional fishing boat with a more rounded shape and a wider bow.
<b>Structural parts (keel and frames)</b>	The basic longitudinal element is the keel, which extends from the bow to the stern. The bow backbone consists of a stem, counterstring, keel joint and additional elements that ensure the strength of the bow structure. The stern backbone of the gajeta consists of a stern loom, a stern counter and an additional connecting elements connected to the keel and the rudder heel. Transverse elements of the structure are frames, webs, beams, brackets and other connecting elements. Longitudinal structural elements are stringer. Gajeta has a bow deck with hatch and mast passage and a small deck structure at the stern. Gajeta has 30 frames.
<b>Planking (external / internal)</b>	The shell plating is made of different materials and is made in several strakes. Each strake has several parts, which depends on the height and shape of the boat and the available material. The width of the first strake close to keel is 140mm and thickness is 25mm. Other layers are generally slightly smaller in width and vary from 100 to 140mm. The thickness of the planking is 20 mm. The layers in the underwater part are made of oak, and in the above-water part of spruce.
<b>Deck and openings</b>	Gajeta has a bow deck with hatch and mast passage and a small deck structure at the stern. The aft deck extends from the stern-post to R4. It extends from the stem to R22. The bow deck has a hatch opening. It is 420 mm long, 410 mm width, located between R2 and R5 in the central plane.
<b>Sails and rig</b>	Gajeta has lateen sail. The mast is made of fir.
<b>Rudder and other steering elements</b>	The rudder is made of oak. The rudder blade is formed from a single piece of wood. It is rounded in shape. The rudder height is 1770 mm. The maximum width of the rudder blade is 410 mm, and the smallest is 180 mm. It is 30 mm thick. The width of the rudder neck is 150 mm.
<b>Other significant elements</b>	
<b>Previous restorations</b>	There is no information about previous restorations.







Insert a photo with a general view of the boat in the frame below



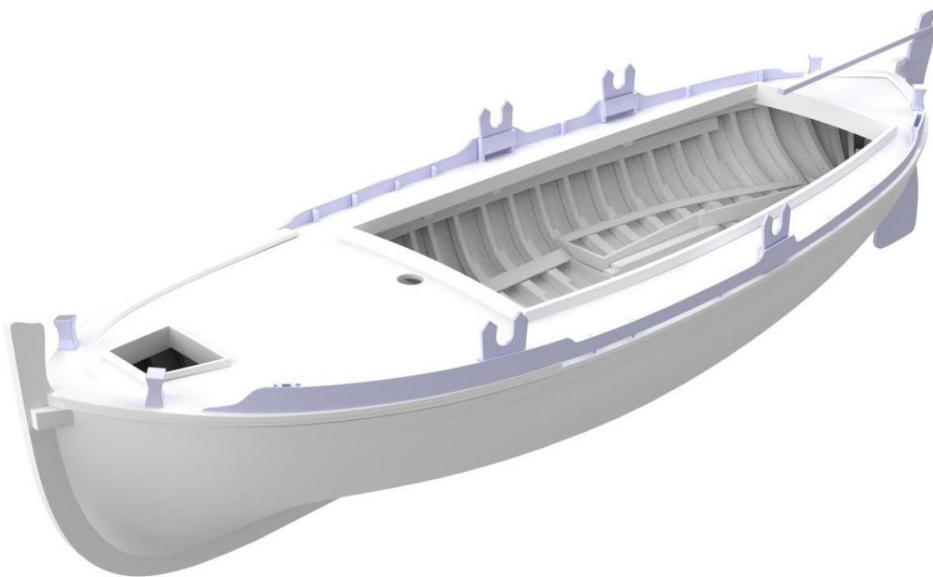





## PP 9 - MUNICIPALITY OF TKON

### Kaić Mateus



## Section 1: boat data

	<p><b>Motivation for the selection of the boat</b> (the grid has the function of identifying and exposing the reason that motivated the selection of this specific boat for restoration and documentation)</p>
<b>Ethnographic / cultural significance</b>	Kaić is traditional boat in Dalmatia region. This project of restoration of authentic boats is important for the preservation of Croatian traditional shipbuilding, which is an important part of Croatian cultural and national heritage.
<b>Historical significance</b>	Kaić was used mainly as additional, auxiliary boats for transporting people on shorter distances, from bay to bay on one island, not for inter-island transport, and as boats for fishing.
<b>Technical / nautical significance</b>	The traditional boat (kaić) represents part of the traditional shipbuilding heritage of the region of island Pašman.
<b>Replica</b>	It is supposed that original boat was built in 1920. The first reconstruction was during the 1969. The main goal of this reconstruction was closing to the original construction of the traditional boat.

	<b>Identification data</b>
<b>Current boat name</b>	Mateus
<b>Current register number (if registered)</b>	BG 1656
<b>Current harbour / location</b>	Tkon, island Pašman

<b>Current owner</b>	
<b>Contact person / site</b>	

	<b>Material data</b>
<b>Boat type / Traditional type</b>	Traditional boat kaić.
<b>Original function</b>	Fishing, passengers transportation
<b>Rig</b>	<i>Treva</i> . The drive was traditionally oars.
<b>Length</b>	Loa = 4.7 m
<b>Breadth</b>	B = 1.65 m
<b>Draught</b>	0,65
<b>Tonnage or weight (if known)</b>	
<b>Main materials and construction features</b>	Hull materials and type of building (e.g. traditional wood building, oak wood, spruce, fir, ash)

	<b>Historical data</b>
<b>Date / period of construction</b>	1920.
<b>Construction place / shipyard or builder</b>	Island Pašman. The original shipbuilder is not known.
<b>Designer, if any</b>	Designer is not known.
<b>Historical presentation</b>	Kaić was renovated in 1969, but it was built long before, and the available data shows that the year of construction was around 1920, somewhere in the area of the island of Pašman. The original shipbuilder is not known. An interesting thing about this boat is the fact that it served as an auxiliary boat for a larger boat which was extracting sand from the sea.
<b>Bibliography / links</b>	Teodor Bernardi: Konstrukcija drvenih brodova, Sveučilište u Zagrebu, Zagreb, 1964. Lucijano Keber: Tradicionalne brodice hrvatskog Jadrana, Architectura navalis Adriatica, Tehnički muzej, Zagreb, 2002. Roko Markovina, Tonči Ukalović: Tradicionalna tehnologija gradnje korčulanske barke – brodice (ribarice-gajete), Simpozij Teorija i praksa brodogradnje SORTA 2010, Split-Lumbarda-Korčula, 07.-09.10.2010.

## Section 2: technical description

<b>Metric data and shape of the hull</b>	Dimensions of kaić vary in different localities. Smaller boats in Dalmatia are, as a rule, less than 4m long. This boat is somewhat longer, 4.7m. These types of boats are finer, slimmer, with transom at stern. They often had a smaller deck with an opening on the bow.
<b>Structural parts (keel and frames)</b>	The keel is made of oak and extends between the bow and stern structure. It is made of one piece approximately 3882 mm long. The width of the keel is 60 mm at the joint with the bow structure, and at the stern (mirror) it is 40 mm. Kaić has 17 frames. They are built of oak. The distance between the frames is from 20 to 25 cm.
<b>Planking (external / internal)</b>	The planking is made of different materials and is made in several strakes, and each strake again in several parts, which depends on the height and shape of the boat and the available timber. The planks are fastened to the frames and webs with 3.4 mm diameter galvanized nails. The number of nails depends on the width of each plate and ranges from 1 to 3 per frame. The thickness of the plank is 20 mm. The width of the first strake is 160mm. Other strakes are generally slightly smaller in width and vary from 100 to 140mm. The strakes in the underwater part are made of oak, and in the above-water part of spruce.
<b>Deck and openings</b>	The original kaić had two decks, one at the bow and one at the stern. The bow deck is made of three pieces of spruce 20 mm thick. The length of the deck is 430 mm measured from the bow structure. The aft deck extends from the aft transom to the R5. It is made of spruce. It consists of six longitudinal pieces and one transverse (bench).
<b>Sails and rig</b>	The mast is made of fir. The height of the mast is 3.8 m, and the diameter at the end is 90 mm. Kaić has traditional sail called <i>treva</i> .
<b>Rudder and other steering elements</b>	The rudder is made of oak and is 30 mm thick. The rudder blade is composed of several parts and the width of the widest part of the rudder blade is 350 mm. The rudder neck is reinforced on both sides. The rudder lever is made of oak, 720 mm long and slightly curved. The rudder is mounted on metal brackets connected by screws to the transom and keel.
<b>Other significant elements</b>	
<b>Previous restorations</b>	There is no information about previous restorations.









Insert a photo with a general view of the boat in the frame below



